

Locata Technology Demonstration for the European Commission

Technical Report v1.5

Contracts

**DEFIS/2020/OP/007-6/Timing Service
DEFIS/2020/OP/007-7/Positioning Solution Service**

**Locata Technical Report v1.5
30 June 2022**

Revision History

Version	Date	Author	Changes
1.0	15-12-21	Locata	Test Plan version 1.0 release
1.1	05-04-22	Locata	Modifications for D210 version 1.1
1.2	08-04-22	Locata	Modifications for D210 version 1.2
1.3	11-05-22	Locata	Modifications for D210 version 1.3, refer to RIDS_Locata_220522.xlsx for detailed change notes
1.5	30-06-22	Locata	Modifications for D210 version 1.5, including: Addition of 'Preamble' section Addition of 'Performance Snapshot' section Addition of Locata alternative PNT performance tables (Table 6-2 and Table 6-17)

Approval

Function	Name	Date	Signature
Reviewed by:			
Reviewed by:			
Approved by:			

Copyright

© Copyright Locata Corporation 2022. All rights reserved.
Not to be reproduced without the written consent of Locata Corporation.

Table of Contents

PREAMBLE	5
PERFORMANCE SNAPSHOT	7
1 INTRODUCTION TO LOCATA TECHNOLOGY	8
1.1 LOCATA INFRASTRUCTURE – LOCATANETS.....	8
1.2 LOCATA RECEIVER / ROVER	9
1.3 CORRELATOR BEAM FORMING (CBF) MULTIPATH MITIGATION ANTENNA TECHNOLOGY.....	10
1.4 CONCEPT OF OPERATION	11
1.5 TIME SYNCHRONIZATION - TIMELOC.....	12
2 TEST & RESULTS SUMMARY	14
2.1 TEST SUMMARY.....	14
2.2 RESULTS SUMMARY.....	15
2.2.1 <i>Time Transfer Summary</i>	15
2.2.2 <i>Positioning Summary</i>	15
3 TIMING TESTS	16
3.1 TEST OVERVIEW	16
3.1.1 <i>Test Configurations</i>	16
3.1.2 <i>Equipment List</i>	18
3.1.3 <i>Locata Equipment Setup</i>	19
3.1.4 <i>Remote Access</i>	19
3.2 TEST CONFIGURATIONS	20
3.2.1 <i>T2A Copper/Coax & T2D Fibre</i>	20
3.2.2 <i>T2B OTA Indoor & T2F OTA Outdoor-to-Indoor</i>	21
3.2.3 <i>T2C OTA Outdoor Local Area Timing</i>	22
3.2.4 <i>T2E OTA Outdoor Wide Area Timing</i>	24
3.2.5 <i>Time Transfer to a Mobile Rover</i>	27
3.3 OTA OUTDOOR TEST SITES	28
3.3.1 <i>JRC Building 72C (Laboratory)</i>	28
3.3.2 <i>JRC Building 48 (Workshop)</i>	29
3.3.3 <i>JRC Building 77 (Tower)</i>	29
3.3.4 <i>Massino Visconti (Mottarone)</i>	30
3.3.5 <i>Como Brunate</i>	31
3.4 TEST SETUP & MEASUREMENT METHOD.....	32
3.4.1 <i>Time Transfer Between LocataLites</i>	32
3.4.2 <i>Time Transfer to a Mobile Rover</i>	35
3.5 MEASUREMENT DATA PROCESSING	37
3.5.1 <i>TIC Logs</i>	37
3.5.2 <i>Locata Logs</i>	38
3.5.3 <i>Time of Day Logs</i>	38
3.6 TEST CASES	39
3.6.1 <i>System Verification – T1</i>	39
3.6.2 <i>Timing Over Copper – T2A</i>	39
3.6.3 <i>Timing OTA Indoor – T2B</i>	39
3.6.4 <i>Timing OTA Outdoor Local Area – T2C</i>	40
3.6.5 <i>Timing Over Fibre - T2D</i>	40
3.6.6 <i>Timing OTA Outdoor Wide Area – T2E</i>	40
3.6.7 <i>Timing OTA Outdoor to Indoor– T2F</i>	40
3.6.8 <i>Time Transfer to a Mobile Rover – T2G</i>	41
4 POSITIONING TESTS	42
4.1 TEST OVERVIEW	42
4.2 TEST SETUP & MEASUREMENT METHOD.....	43
4.2.1 <i>Test Equipment</i>	43
4.2.2 <i>Measurement Method</i>	48
4.3 COORDINATE TRANSFORMATIONS	50

4.3.1	<i>Local Coordinates</i>	50
4.3.2	<i>ECEF Coordinate Transformation</i>	51
4.3.3	<i>JRC Survey Coordinates</i>	52
4.4	LOCATANETS, REFERENCE SYSTEMS, AND TEST TRACKS/POINTS	53
4.4.1	<i>Outdoor LocataNet – Konecranes, Düsseldorf, Germany</i>	53
4.4.2	<i>Indoor LocataNet – JRC Building 48 (Workshop)</i>	55
4.5	MEASUREMENT FORMATS	55
4.6	TEST CASES	56
4.6.1	<i>System Verification – T1</i>	56
4.6.2	<i>Static Outdoor Positioning – T6A</i>	56
4.6.3	<i>Kinematic Outdoor Positioning – Operational Environment – T6B</i>	56
4.6.4	<i>Static Indoor Positioning – T7A</i>	57
4.6.5	<i>Kinematic Indoor Positioning – T7B</i>	57
4.7	EQUIPMENT LIST – POSITIONING TESTS	58
5	LOCATA RESILIENCE & MONITORING TESTS	59
5.1	TEST OVERVIEW	59
5.2	TEST METHOD	59
5.2.1	<i>Remote Monitoring</i>	59
5.2.2	<i>System Resilience Features</i>	60
5.3	TEST CASES	61
5.3.1	<i>System Verification – T1</i>	61
5.3.2	<i>Remote Monitoring – T8A</i>	61
5.3.3	<i>Bracing – T8B</i>	62
5.3.4	<i>Dual Master – T8C</i>	62
6	TEST RESULTS	63
6.1	TIMING PERFORMANCE	63
6.1.1	<i>Timing Performance Summary</i>	63
6.1.2	<i>T2A – Copper/Coax Cable</i>	73
6.1.3	<i>T2B – OTA Indoor</i>	77
6.1.4	<i>T2C – OTA Outdoor Local Area</i>	80
6.1.5	<i>T2D – Fibre Optic</i>	84
6.1.6	<i>T2E – OTA Outdoor Wide Area</i>	88
6.1.7	<i>T2F – OTA Outdoor to Indoor</i>	93
6.1.8	<i>T2G – Time Transfer to a Mobile Rover</i>	96
6.1.9	<i>Allan Deviation Plots</i>	97
6.1.10	<i>Time of Day Messages</i>	108
6.2	POSITIONING PERFORMANCE	112
6.2.1	<i>Positioning Performance Summary</i>	112
6.2.2	<i>Indoor Positioning</i>	113
6.2.3	<i>Outdoor Positioning</i>	122
6.3	RESILIENCE & NETWORK MONITORING PERFORMANCE	133
6.3.1	<i>Network in Normal Operation</i>	133
6.3.2	<i>LocataLite 10 - Powered Down</i>	134
6.3.3	<i>LocataLite 10 - Returned to Service</i>	136
6.3.4	<i>LocataLite 10 - Negotiating to Take Over as Master</i>	138
6.3.5	<i>LocataLite 10 - About to Take Over as the Master</i>	139
6.3.6	<i>LocataLite 10 - Takes Over as the Master</i>	140
7	ACKNOWLEDGEMENTS	141

Preamble

The detailed and very comprehensive Technical Report below was generated from test data independently recorded by engineers from the European Commission's **Joint Research Centre (JRC)**. The JRC is located in Ispra on the shores of Lake Maggiore (Northern Italy) and after more than 50 years of development, it is firmly established as one of Europe's largest research campuses.

Locata Corporation's proprietary positioning and timing technologies were being assessed and tested as part of a larger contracted project, the details of which are as follows:

1. On the 26/10/2020 the European Commission, DG Defence Industry and Space (**DEFIS**) posted a "Call for Tenders"^[1] notice on the official eTendering website.
2. The Tender reference Number was **DEFIS/2020/OP/0007** and its title was "**Alternative Position, Navigation and Timing (PNT) Services**" (or more commonly, **Alt-PNT**)
3. On the 5/11/2020 the EC and the JRC hosted a public, 2-hour webinar which detailed tests the Commission wanted to carry out, the "minimum technical requirements" which would determine tender selection, pictures of the JRC campus where testing would occur, tender KPI's, and other relevant information requested by prospective applicants.
4. **The objectives of the DEFIS tender** were succinctly summarized in one simple slide from the Webinar, as shown in Figure P-1. Only 7 technologies would be selected for testing; a panel of subject-matter experts would choose the winners.

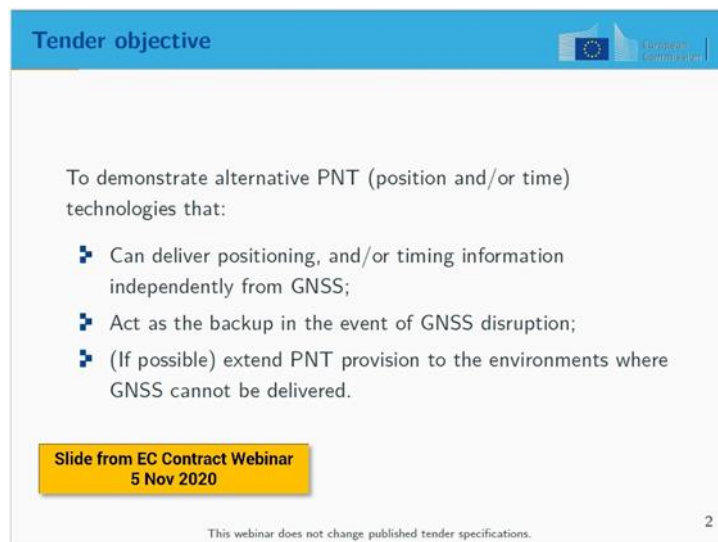

Figure P-1: Tender Objectives slide from EC Contract Webinar

5. The tender objective accurately described the proprietary terrestrial positioning and timing technologies Locata has been developing and selling for a decade. Locata Management therefore applied for two of the seven available slots, and won contracts for *both* Alternative Positioning demonstrations *and* Alternative Timing demonstrations. Locata was the only company that was granted two contract wins.
6. On 19/08/2021, after a lengthy tender process, the EC issued two contracts to Locata:
 - a. DEFIS/2020/OP/0007-6/Timing Demonstration Contract and;
 - b. DEFIS/2020/OP/0007-7/Positioning Demonstration Contract.

^[1] DEFIS "Call for Tenders" Notice: <https://etendering.ted.europa.eu/cft/cft-display.html?cftId=6965>

7. Over the next few months Locata engineers planned the technology demonstration whilst Locata management organized the supporting logistics required to send a great deal of equipment overseas for testing.
8. *Locata prepared a detailed test plan designed to demonstrate the entire suite of technology capabilities Locata believes are required to deliver totally-independent, Alt-PNT solutions for real-world applications.* Locata wanted to ensure the EC tested every technology element Locata wanted to showcase. The Locata team arrived at Ispra on 23/2/2022 for site setup, and the final tests were completed on 6/4/2022. Even a casual inspection of the lengthy Technical Report below will highlight the large number of totally new Alt-PNT technology developments Locata demonstrated.
9. The JRC has advised tender winners that the test results, detailed in the individual Technical Reports prepared for each tested technology, will likely be published in Q4/2022.

Performance Snapshot

For readers that do not have time to study the entire document, yet desire a snapshot synopsis of Locata test results, two slides are included below. Both were presented to a large meeting of EC executives and engineers for a so-called “Demo Day”, held at the JRC on 18th May, 2022. On Demo Day Locata gave live demonstrations of indoor time synchronization and indoor positioning. Locata’s slide deck was presented later that day and live streamed to registered guests. The two slides detail high-level summarized results recorded by the JRC for both Timing (Figure P-2) and for Positioning (Figure P-3).

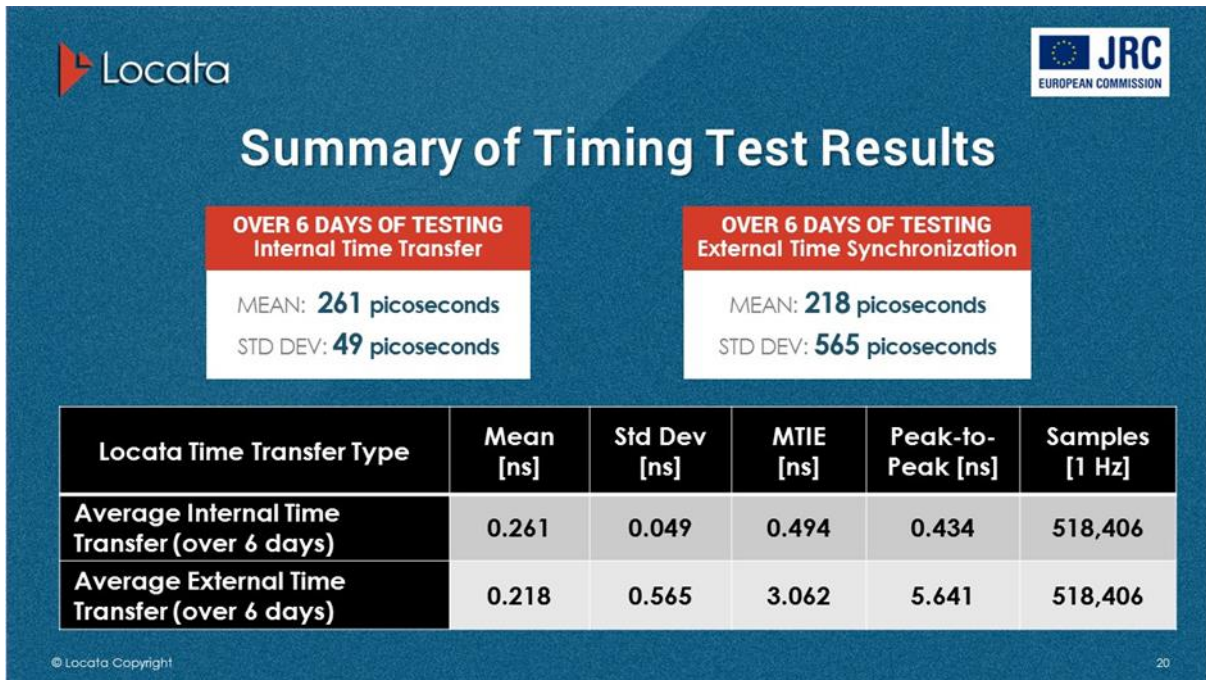

Figure P-2: Summary of Timing Test Results

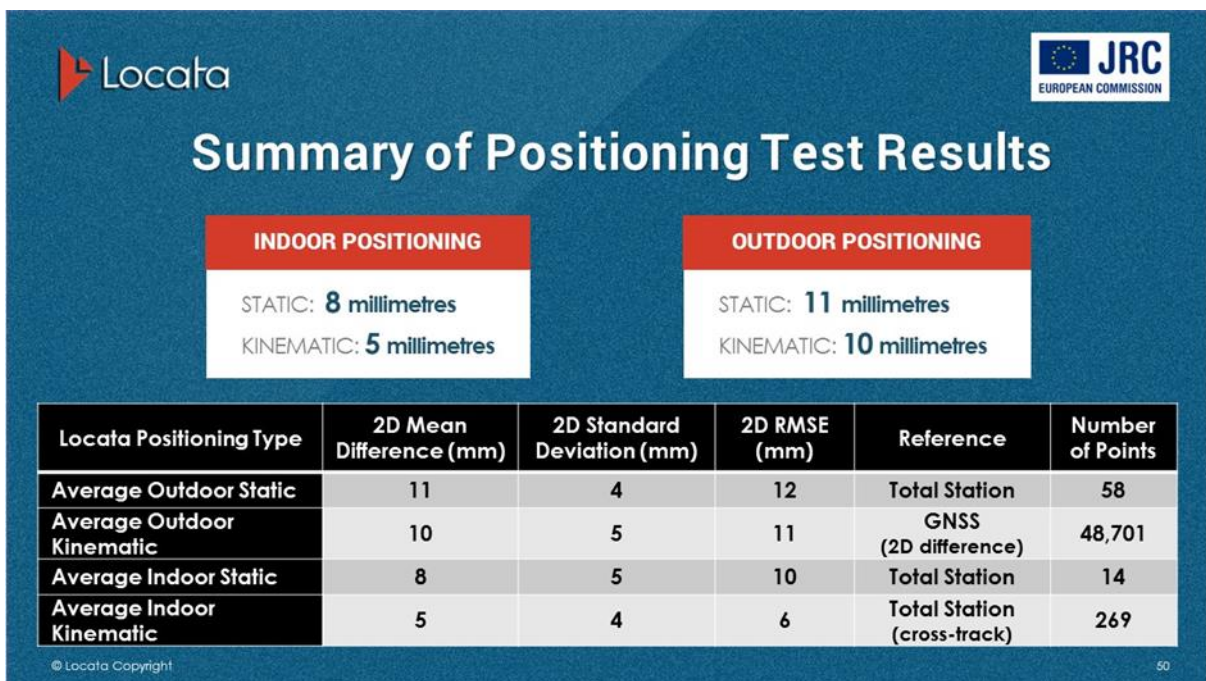

Figure P-3: Summary of Positioning Test Results

1 Introduction to Locata Technology

Unlike GPS, which was developed as a military system and later exploited for public, civilian, and commercial applications, Locata technology is a privately developed commercial-off-the-shelf system. It was designed from scratch to provide reliable and accurate PNT services that are customizable to meet the present and future requirements of many modern applications that space-based legacy PNT cannot reliably service. Locata is not aware of any other candidate alternative PNT technology that can deliver these centimetre and sub-nanosecond level capabilities of Locata, separately or simultaneously:

- High-precision Survey-Grade Carrier-Phase Solution: ~ cm-level accuracy
- Lower-precision Consumer-Level Code and/or Angle-of-Arrival Solution: ~ meter-level accuracy
- Network Self Synchronization: $\leq 1\text{ns}$
- Frequency Stability: $\sim 1 \times 10^{-15}$ (one part per trillion, which is better than Stratum 1 specification)
- Unprecedented Multipath Mitigation: cm-level indoors and in difficult industrial environments, where multipath remains by far the largest (and still-unresolved) error source for other radionavigation systems.

1.1 Locata Infrastructure – LocataNets

Locata technology developments create terrestrial networks of Locata transmitters — “LocataNets”— which are essentially “local ground-based replicas” of the functionality provided by space-based GNSS-style satellite constellations. Within its’ signal coverage area, a LocataNet delivers all the PNT capabilities that GNSS could. Furthermore, unlike GNSS, LocataNets can deliver the same functionality in multipath-rich environments like urban canyons and within indoor environments.

Locata transmitters, known as LocataLites, are the Locata equivalent of satellites in a GNSS constellation. Current production LocataLites transmit FCC or CE-approved CDMA signals on two frequencies within the global, license-free 2.4 GHz ISM band, from two spatially separated antennas. Today’s LocataLites (shown in Figure 1-1) are 134 x 241 x 28 mm and weigh ~1.4 kg, not including external antennas and a 12-28 VDC power source. They are a very compact source of powerful positioning and synchronization signals. LocataLites can be preconfigured and easily deployed in the field. As an option, LocataLites can be monitored, configured, and upgraded remotely via secure device access protocols that meet current industry cybersecurity practices, and their software/firmware can be updated in situ in the field. LocataLites can be readily added to, relocated, or reconfigured within a network, effectively modifying LocataNet characteristics in a dynamic manner to fit user needs anytime they may change. These capabilities are available today and are used extensively by Locata customers in applications that require frequent reconfiguration of service coverage areas, like deep pit mining. LocataLites currently employ numerous industry standard communication ports, including RS-232 serial, RS-485 serial, IEEE 802-3 LAN, and USB.



Figure 1-1: Locata Transmitter – LocataLite (with top cover removed)

LocataNets can be designed to service practically any type of service area or a service volume by placing the LocataLites to achieve the necessary 2D or 3D geometry, governed by the same visibility and geometry principals which apply to GNSS position solutions. Because of this ability to customize Locata performance deliverables and LocataLite placement, users both on the ground and in the air can “design in” ultra-reliable access to cm-level PNT service that can include precise nanosecond-level synchronization for applications which require it (such as 5G mobile systems). Since LocataNets scale extremely well, deployments covering areas from as small as an office to a few square miles (e.g. airfield, harbor or port ^[2], etc.) to thousands of square miles (e.g. USAF White Sands Missile Range in New Mexico, USA ^[3]) can all be created simply by using the same commercial-off-the-shelf production LocataLites. All of this is achieved without GPS or any other GNSS.

It should be noted here that next-gen LocataLites are currently being designed which will ultimately be chip-based, providing an alternative form-factor to the current, more-expensive devices which are FPGA-based. This miniaturization will deliver a substantial reduction in SWaP-C for next-generation Locata networks, and therefore be capable of addressing more cost-sensitive markets like consumer devices and mobile phones.

1.2 Locata Receiver / Rover

Locata Receiver/Rover is functionally and physically like a professional GNSS receiver. A Locata Rover tracks all visible LocataLite signals and performs acquisition, tracking, and positioning functions in a very similar way to a GNSS receiver. Locata Rovers can be direct drop-in replacements for GNSS receivers when the appropriate Locata network is available and the device interfaces (e.g. NMEA data) are compatible. The Locata Rover today is 140 x 146 x 28 mm in size and weighs ~0.8 kg (not including an external antenna and a 12-28 VDC power source). The Rover delivers a completely passive PNT solution which, if desired, can be networked via Ethernet or other available communication links for remote tracking, monitoring, or other situational awareness applications. Current Rovers are equipped with numerous industry standard communication ports, including USB, RS-232 serial, RS-485 serial, and IEEE 802-3 LAN. The Rovers support industry standard NMEA protocols and a proprietary binary protocol by default. They have purposefully been designed to be highly configurable to enable purchaser customization to suit requirements. A Locata Rover with the top cover removed is shown in Figure 1-2.

Locata Rovers today can operate with a small 2.4 GHz monopole “stick” antenna in environments where high levels of multipath are not present (e.g. open sky mining applications). Many other antennas can also be used for differing environments, in the same way that GNSS receivers can use a patch or choke-ring antenna, or other antenna versions, for various differing applications.



Figure 1-2: Locata Receiver – a Rover (with top cover removed)

^[2] GPS World, December 2020: <https://editions.mydigitalpublication.com/publication/?i=684356>

^[3] GPS World, August 2016: <http://digital.gpsworld.com/Aug2016>

While a Locata Rover may operate as a standalone device, there are applications where Locata technology partners have successfully demonstrated that Locata can be easily integrated within the positioning algorithms of a GNSS receiver as “just another GNSS constellation” (albeit a ground-based one). This unique development is used today in mine machine automation systems and forms a robust GNSS+Locata “system of systems”. This “combined GNSS+Locata solution” leverages the best characteristics of each technology: it can operate as a standalone GNSS or as a standalone Locata system. But, in many GNSS-obstructed situations it simultaneously uses, as an example, a combination of GNSS satellites *and* LocataLites which are “in view” of the receiver. In this way it continues to reliably provide a cm-level position solution to autonomous machinery whereas a GNSS-only solution would certainly fail.

Like the in-development LocataLite upgrades described in Section 1.1 above, Locata is currently designing next-generation Rovers which can eventually be chip-based, and hence offer a cheaper alternative to our current devices which are FPGA-based. This miniaturization will deliver substantial reduction in SWaP-C for next-generation Locata-designed Rovers. **Importantly, Locata IP for the Rovers can be built into other companies’ GNSS chipsets, making the incremental add-on cost for Locata functionality in that scenario very low – fundamentally compromising an IP license fee.** In other words, a combined Galileo-Locata chipset is basically no more difficult to design, nor necessarily be more expensive than, a combined Galileo-GPS chipset. This can represent a fertile and valuable new development possibility for EU-based companies that wish to deliver valuable alternate PNT capabilities to new global markets.

1.3 Correlator Beam Forming (CBF) Multipath Mitigation Antenna Technology

Locata has also invented and commercialized a revolutionary new technology known as Correlator Beam Forming (CBF) for environments with severe multipath such as urban canyon and indoor applications. This new technology is already embedded in Locata Rovers being manufactured today. CBF technology allows the Locata Rovers (paired with a suitable CBF antenna) to identify and track the direct Line-of-Sight signals from LocataLites while rejecting the vast number of complex reflected multipath signals. The Locata antenna that works in lockstep with CBF is trademarked as the Locata VRay™. The multi-element design of the VRay antenna (shown in Figure 1-3) enables accurate PNT for indoor applications and environments that are severely degraded by multipath, such as urban areas or container terminals. Today’s commercial VRay “Orb-shaped” antenna variant is spherically shaped, about the size of a basketball, and weighs approximately 4 kg. It should be noted, however, that the VRay is currently undergoing miniaturization development in the same way that the Locata Rovers and LocataLites are being miniaturized, through to a chip-scale development.

The current VRay Orb antennas enable a Rover to deliver cm-level accurate PNT service in severe multipath-affected environments where other radiolocation technologies constantly fail. In addition to all other Locata performance parameters described above, CBF combined with the VRay antenna enables – for the first time – autonomous 3D orientation of the Rover platform to an accuracy of ± 1 degree whilst using only a single VRay Antenna and only one Rover receiver. To our knowledge this is a completely unique capability and has never been achieved before by any other company or device.

Whilst the CBF technology is presently applied to the receiver end with a VRay antenna connected to the Rover, CBF and VRay technology can be deployed in other combinations to allow miniaturization of the Rover antenna. This capability is already designed and slated for commercial release in the next-generation Locata hardware.



Figure 1-3: Locata VRay (“Orb”) Multipath Mitigation Antenna (a current production 60-element version shown)

1.4 Concept of Operation

There are many similarities between the way Locata and GNSS operate. A comparison is presented here using an example of the LocataNet installed at the famed Insurance Institute for Highway Safety (IIHS) ^[4] in Virginia, United States. IIHS is one of the two organizations responsible for safety testing and rating all the new vehicle models entering the US market against the US Federal Motor Vehicle Safety Standards. As pictured in Figure 1-4, part of the IIHS LocataNet site includes a 200 x 50 m (almost 5 acre) covered area under a canopy structure, known as the Lower Track. This area cannot be serviced by GNSS as the huge canopy covering blocks satellite signals (as in any indoor area). Because IIHS engineers require better than 10 cm (95 %) positioning service coverage with high reliability and repeatability, they installed and commissioned a LocataNet to deliver those capabilities. The IIHS Locata system has now been fully operational and in constant daily use by the IIHS since 2015. The Locata service area covers the Lower Track and the open sky Upper Track. The IIHS has relied exclusively on Locata for all race and under-cover test track positioning and navigation requirements since then (GNSS is not used).

The IIHS LocataNet uses 16 LocataLites, with one of the LocataLites on the Upper Track configured as the “Master LocataLite” for this LocataNet. Most LocataLites in the Upper Track use the broadcasted signals of this Master LocataLite to precisely time synchronize themselves using Locata’s TimeLoc™ technology (discussed later in this section). LocataLites which are not in view of the Master LocataLite use the signals of already TimeLoc’d LocataLites to synchronize themselves to the Master LocataLite. LocataLites in the Lower Track are also time synchronized by using this principal of “cascading” TimeLoc from one device to another. The IIHS’s LocataNet has been optionally synchronized to GPS time (an in-built feature) simply because the IIHS requires UTC time for test protocols. This feature ensures timestamps for measurements from different sensors on IIHS vehicles are aligned for easy analysis.

Locata Rovers (using monopole “stick” antennas) are mounted on IIHS test vehicles and they interface with IIHS test equipment, in exactly the same way any GNSS receiver would. The IIHS LocataNet is designed to provide seamless alternative PNT coverage for both open and covered tracks. As shown in Figure 1-4, Locata Rovers position themselves using the ranging signals from the LocataLites with Line-of-Sight view, in the same way as a GNSS receiver would by using the signals from visible GNSS satellites.

^[4] A new chapter for IIHS vehicle research:

<https://www.youtube.com/watch?v=xI4eJUOSMBQ&list=PL4D1CCA24D5A4470F&index=3&t=151s>

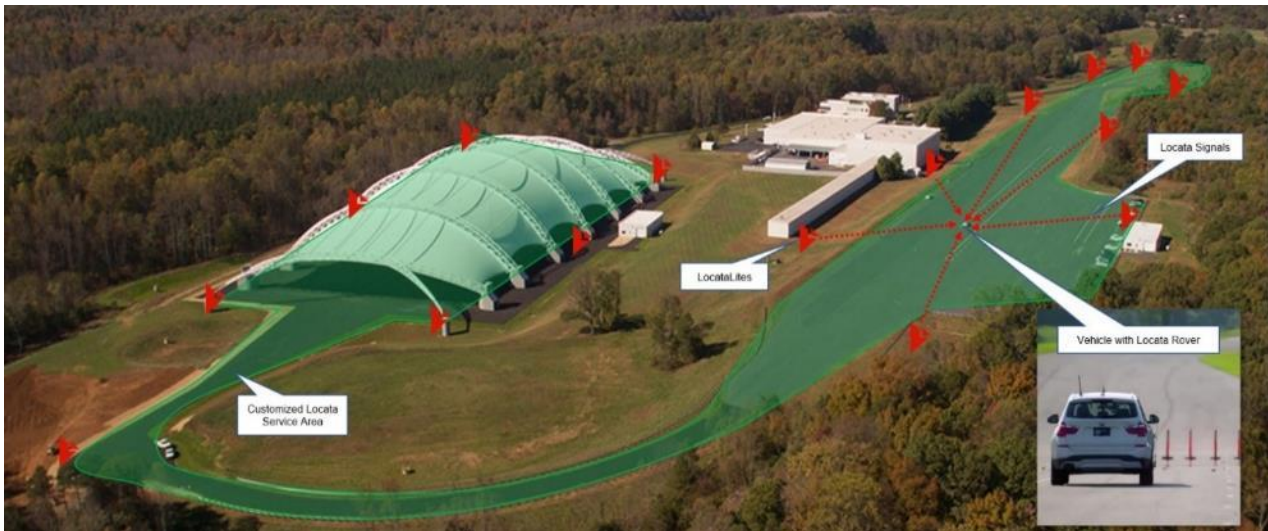

Figure 1-4: LocataNet Installation at the Insurance Institute for Highway Safety (IIHS) in Virginia, USA

1.5 Time Synchronization - TimeLoc

TimeLoc is Locata’s patented wireless time synchronization technology. It enables a LocataLite to use the broadcast ranging signals of another LocataLite for precise time synchronization. **TimeLoc enables sub-nanosecond level synchronization without using atomic clocks, or any form of external aiding or correction data.** TimeLoc can be cascaded from one LocataLite to another LocataLite in a local or wide-area network; this “meshing” capability is exceptionally scalable and provides completely-autonomous, internal, high-accuracy self-synchronization. That is the critical enabling capability which is required to produce GNSS-like radiopositioning. TimeLoc’s synchronization capability is inherently available in each LocataLite in a LocataNet.

Figure 1-5 is a simple illustration of how time synchronization takes place in a LocataNet like that installed for the IIHS. In this example case the Master LocataLite acts as the time source for the LocataNet and determines a “LocataNet Time”. As described before, all other LocataLites time synchronize themselves to the “LocataNet Time” using the direct or cascaded TimeLoc. Once the entire LocataNet is time synchronized, any LocataLite in the LocataNet can act as a remote time source of the “LocataNet Time”. Locata Rovers (i.e. the receiver using Locata ranging signals for PNT within a LocataNet coverage area) can also achieve time synchronization with a standard deviation of <10 nanoseconds.

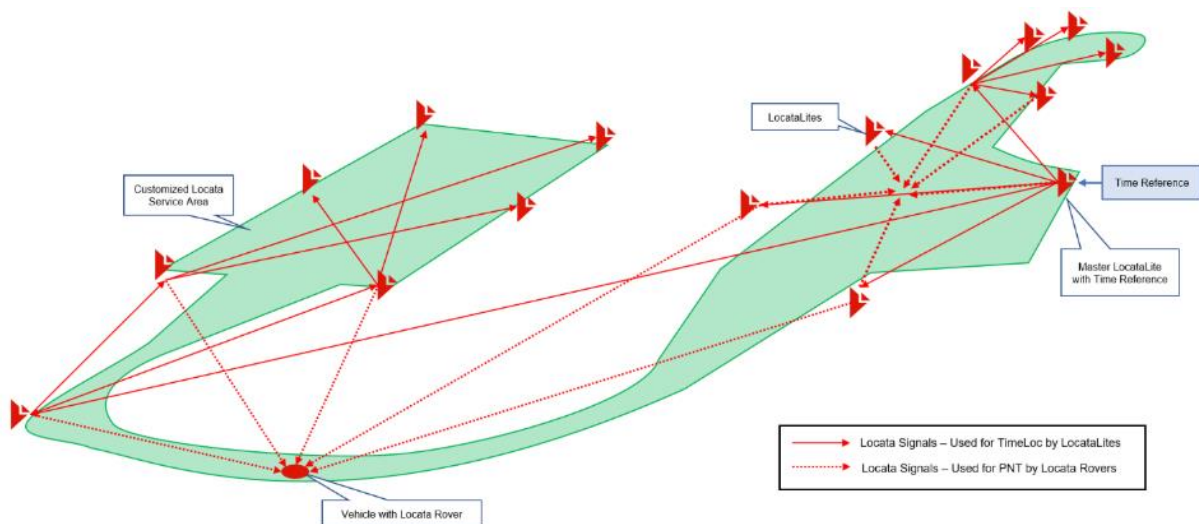

Figure 1-5: TimeLoc Time Synchronization in a LocataNet

By default, the Master LocataLite oscillator becomes the source for the “LocataNet Time” in standalone operation. However, any other time reference source (such as an atomic clock, national timing lab feed, or a GNSS timing signal) may optionally be fed to the Master LocataLite to establish *that* external reference as “LocataNet Time”. Real-world performance data gathered by the USAF and the USNO ^[5] has shown that the Master LocataLite can maintain time synchronization relative to a given reference time source such as UTC or an atomic clock. In 2019, the U. S. Naval Observatory (USNO), which maintains the GPS Master Clock, additionally conducted and then reported on independent tests of Locata time transfer capabilities at the U.S. Air Force’s White Sands Missile Range over long ranges (~74 km) ^[6]. These published USAF and USNO test results (reported in multiple journal articles and at GNSS industry conferences) independently confirm Locata’s synchronization performance. **The tests conducted in 2022 by the European Commission at the Joint Research Centre – which are reported in depth in the pages below – again independently and unequivocally validate the unique technology capabilities developed by Locata.**

^[5] GPS World, October 2015: <http://digital.gpsworld.com/October2015>

^[6] GPS World, January 2020: <https://editions.mydigitalpublication.com/publication/?i=646249>

2 Test & Results Summary

2.1 Test Summary

Table 2-1 summarizes all tests conducted.

Test ID/ Name, Location	Output	Date, Duration & Method	Metrics
Short term clock stability & time transfer performance T2A – Copper/coax cable T2B – OTA indoor T2C – OTA outdoor local area T2D – Fibre optic T2E – OTA outdoor wide area T2F – OTA outdoor to indoor T2G – Time transfer to a mobile rover	PPS, LBMP, ToD Data (ZDA)	March 12 - 26, 2022 JRC Ispra T2A – T2F: Collect 24 hrs TIC, LBMP, ZDA for each test. T2G: Collect 4 hrs TIC and ZDA.	Number of Samples, Mean, Peak to Peak, Standard Deviation, 3-Sigma, Maximum Time Interval Error, Allan Variance (AVAR, OAVAR, MVAR), Allan Deviation (ADEV, OADEV, MDEV)
Operational Environments T6A – Outdoor static (GNSS & Total Station as references) T6B – Outdoor kinematic (GNSS as reference)	PVT (NMEA & LBMP)	April 6, 2022 Düsseldorf, Germany 58 static points dwelling at least 1 minute per point. 6 routes with 2 to 4 repeats each.	Boxplot per point (T6A) CDF of 2D difference against GNSS (T6B)
Indoor Positioning T7A – Indoor static (Total Station as references) T7B – Indoor kinematic (Total Station as reference)	PVT (NMEA & LBMP)	March 10, 2022 JRC Ispra 7 static points dwelling at least 1 minute per point. Reoccupy same points in reverse. North-South and East-West routes with at least 2 repeats.	Boxplot per point (T7A) CDF of cross-track error against Total Station (T7B)
Resilience & network monitoring (same as T4) T8A – Remote monitoring T8B – Bracing T8C – Dual Master	HTML pages showing device status and the failover response	March 24, 2022 - JRC Ispra < 30 min each	Pass / Fail

Table 2-1: Test Summary

2.2 Results Summary

2.2.1 Time Transfer Summary

The cumulative duration over all timing tests was 6 days (144 hours).

- The average Locata internal time transfer performance over all timing tests was 261 picoseconds with a standard deviation of 49 picoseconds.
- The average Locata external time transfer performance over all timing tests was 218 picoseconds with a standard deviation of 565 picoseconds.
- The average Locata time transfer to a mobile Rover was 1.2 nanoseconds with a standard deviation of 0.7 nanoseconds.

Table 2-2 shows Locata average time transfer performance across all timing tests.

Locata Time Transfer Type	Samples [1 Hz]	Mean [ns]	Peak-to-Peak [ns]	MTIE [ns]	Std Dev [ns]	3 Sigma [ns]
Average Internal Time Transfer (over 6 days)	518406	0.261	0.434	0.494	0.049	0.147
Average External Time Transfer (over 6 days)	518406	0.218	5.641	3.062	0.565	1.695
Time Transfer to Mobile Rover	14401	1.238	3.3	2.9	0.745	2.235

Table 2-2: Locata Time Transfer Performance Summary

2.2.2 Positioning Summary

- The average Locata outdoor positioning performance was 11 mm static and 10 mm kinematic with 4 mm and 5 mm standard deviation, respectively.
- The average Locata indoor position performance was 8 mm static and 5 mm kinematic with 5 mm and 4 mm standard deviation, respectively.

Table 2-3 shows Locata average positioning performance across all positioning tests.

Locata Positioning Type	Reference	Number of Points	2D Mean Difference (m)	2D Standard Deviation (m)	2D RMSE (m)
Average Outdoor Static	Total Station	58	0.011	0.004	0.012
Average Outdoor Kinematic	GNSS (2D difference)	48701	0.010	0.005	0.011
Average Indoor Static	Total Station	14	0.008	0.005	0.010
Average Indoor Kinematic	Total Station (cross-track)	269	0.005	0.004	0.006

Table 2-3: Locata Positioning Performance Summary

3 Timing Tests

3.1 Test Overview

Locata time transfer tests were designed to show the technology’s capability to transfer precise time over very short distances, such as across a room, to very long distances such as between cities.

Different Over-The-Air (OTA) paths were used to show the local and wide area performance of the system. Furthermore, other transmission media including fibre optic cable and coax cable were used to illustrate the flexibility of Locata technology. Tests included a local area component – all within the Joint Research Centre (JRC) facility in Ispra Italy – and a wide area component which cascaded outside the JRC premises.

In addition, UTC time from an OTA outdoor ‘timing backbone’ was used to synchronize an indoor positioning network, demonstrating UTC time transfer to an indoor Locata Rover.

The tests were designed to measure the following properties of Locata precise time transfer capability:

1. Stability of the transferred UTC time compared to an independent UTC reference time
2. Accuracy of Locata time synchronization and transfer
 - a. Internal time transfer – LocataLite origin to LocataLite destination time transfer accuracy
 - b. External time transfer – Locata UTC time source to LocataLite origin time transfer accuracy

Other objectives of the tests were to demonstrate the following Locata technology capabilities:

1. Time transfer via different media including OTA radio, coax cable, or fibre optic
2. Time transfer over short (under 10m) and long (above 40 km) single hops
3. Time transfer over multiple hops over long distances (8 hops and over 100 km)
4. Synchronization of local devices (indoor positioning) from any other LocataLite
5. Flexibly to perform both point-to-point and point-to-multi point time transfer
6. Time transfer to a mobile stationary or moving asset, using a Locata Rover/Receiver

3.1.1 Test Configurations

The following table summarizes the test configurations.

Test ID/ Name, Location	Output	Date, Duration & Method	Metrics
T1 System verification	DUT is ready	Day 1 of all tests < 30 min (test time) - setup validation only	Pass / Fail
Short term clock stability & time transfer performance T2A – Copper/coax cable T2B – OTA indoor T2C – OTA outdoor local area T2D – Fibre optic T2E – OTA outdoor wide area T2F – OTA outdoor to indoor T2G – Time transfer to a mobile rover	PPS, LBMP, ToD Data (ZDA)	March 12 - 26, 2022 JRC Ispra T2A – T2F: Collect 24 hrs TIC, LBMP, ZDA for each test. T2G: Collect 4 hrs TIC and ZDA.	Number of Samples, Mean, Peak to Peak, Standard Deviation, 3-Sigma, Maximum Time Interval Error, Allan Variance (AVAR, OAVAR, MVAR), Allan Deviation (ADEV, OADEV, MDEV)

Table 3-1: Timing Test Case Summary

In all test configurations a Master LocataLite was synchronized to an external UTC time standard and this time was subsequently transferred to other LocataLites within the LocataNet. UTC time was transferred, either directly or through intermediary LocataLites, to an End-Node LocataLite that output time for external equipment to measure against a UTC reference. This setup was installed in the Laboratory of JRC Building 72C as illustrated below in Figure 3-1.

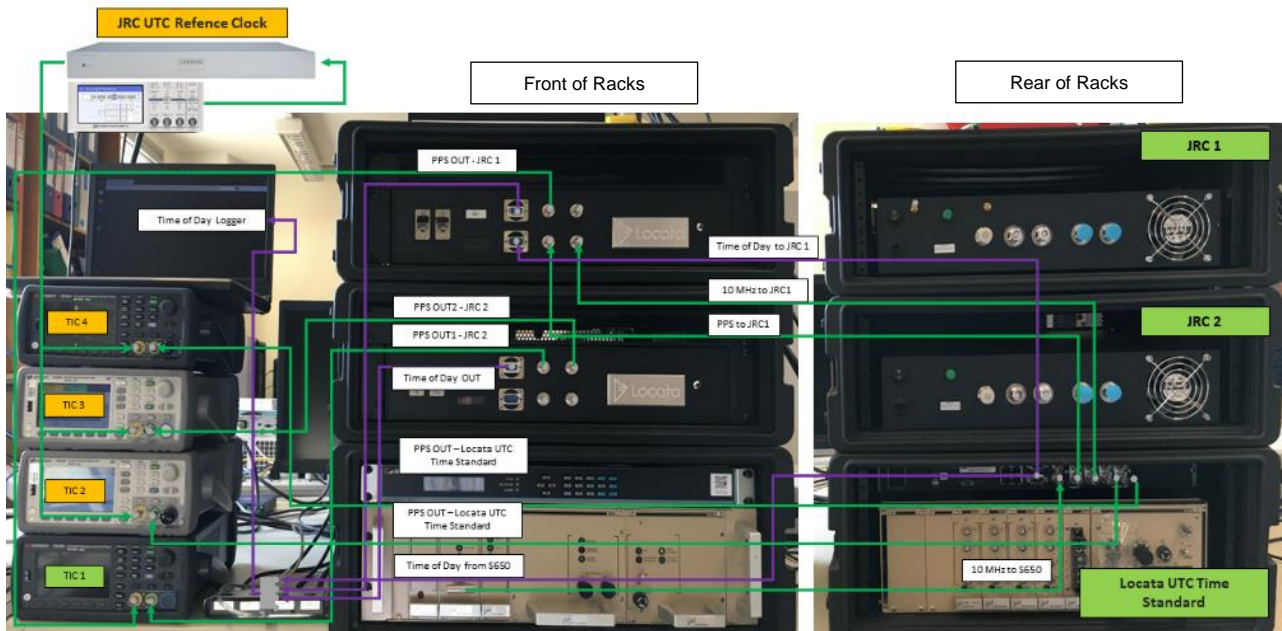

Figure 3-1: Laboratory Test Setup in Building 72C

Figure 3-2 shows one of the intermediary installations with two LocataLites and two dish antennas per LocataLite on JRC Building 77 (Tower).



Figure 3-2: LocataLite Setup with Dish Antennas at the JRC Tower for Wide Area Time Transfer

3.1.2 Equipment List

Table 3-2 shows the equipment list for all variants of the T2 timing tests.

Parts List	Number of Units	Supplier	Notes
LocataLites	14	Locata	Enclosed within road cases incorporating 4G modems and/or 5 GHz Wi-Fi for remote access
Locata Rover	1	Locata	Enclosed within a road case.
LocataLite Antennas and cables	30	Locata	Parabolic dish, cube, and wall antennas
4G Antennas (only for communications)	5	Locata	For one of the LocataLites at each of the 5 sites, used for remote monitoring purposes
Locata Rover Antenna and cables	1	Locata	VRay Orb antenna
Locata UTC Time Standard	1	Locata	Microchip SyncServer S650 disciplined from a Ball Efratom MRK Rubidium time standard
Time Interval Counters (TICs)	4	JRC	Keysight 53230A Time Interval Counters (3 for measurement, 1 for monitoring)
JRC UTC Reference	1	JRC	Stanford Research Systems FS740 GNSS disciplined Rubidium time standard with Meinberg SDU PPS distribution unit
Laptop	2	Locata	Time of Day logging Rover position display Demonstration of remote monitoring

Table 3-2: Equipment List for Timing Tests

3.1.3 Locata Equipment Setup

Locata devices were distributed over the following 5 sites:

- JRC Building 72C (Laboratory)
 - Master LocataLite JRC-1
 - End-Node LocataLite JRC-2
 - JRC UTC Reference
 - Locata UTC Time Standard
 - TICs
 - Laptop-1
- JRC Building 48 (Workshop)
 - LocataLite Workshop-1
 - LocataLite Workshop-2
 - LocataLite Indoor 10, 11, 12, 13, and 14
 - Locata Rover
 - Laptop-2
- JRC Building 77 (Tower)
 - LocataLite Tower-1
 - LocataLite Tower-2
- Massino Visconti (Mottarone)
 - LocataLite Mottarone-1
 - LocataLite Mottarone-2
- Como Brunate
 - LocataLite Como

3.1.4 Remote Access

LocataLites and Locata Rovers do not require any external communication channels for operation. However, remote access to each site was desirable to facilitate remote monitoring, logging, and Locata device configuration changes for each test case. This was particularly important for the very distant sites Massino Visconti and Como Brunate, 8km and 44km away from the JRC, respectively.

Each LocataLite site was equipped with a 4G modem and an external log periodic 4G antenna, which was shared between co-located devices. These were:

- Master LocataLite JRC-1
- LocataLite Workshop-1
- LocataLite Tower-1
- LocataLite Mottarone-1
- LocataLite Como

Other co-located devices at each site were also able to share the one 4G connection via either an ethernet or 5GHz Wi-Fi local area network.

3.2 Test Configurations

3.2.1 T2A Copper/Coax & T2D Fibre

Timing tests were conducted over two types of fixed-line media, those being coaxial and fibre optic cable. These cables were connected directly between Master LocataLite JRC-1, and End-Node LocataLite JRC-2. A 50m LMR400UF coax cable, with velocity factor of 84% was used for coax, while a 1km single-mode fibre line, with velocity factor of approximately 67% was used for fibre. The setup for each test is shown with an illustrated wiring diagram, Figure 3-3 for the coax and Figure 3-4 for the fibre.

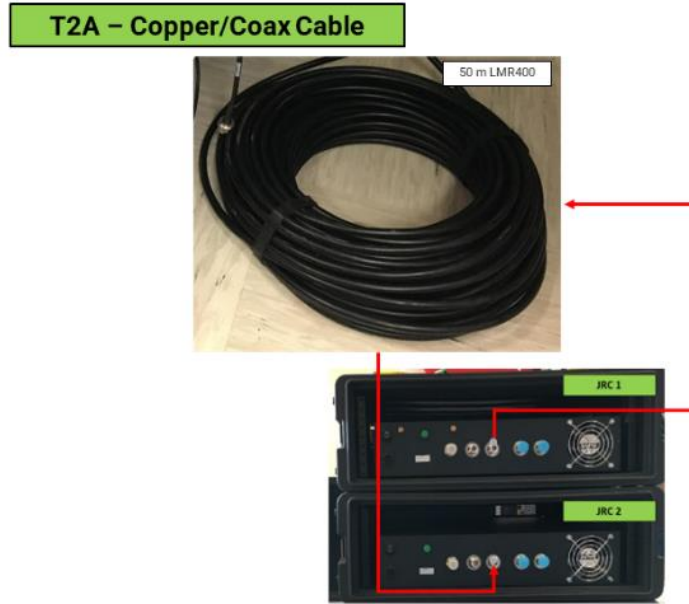

Figure 3-3: T2A Copper/Coax Cabled Timing Test Setup

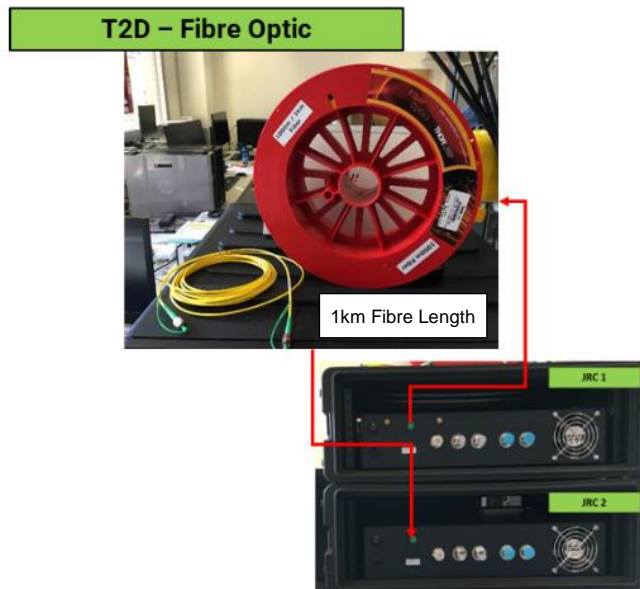

Figure 3-4: T2D Fibre Optic Cabled Timing Test Setup

3.2.2 T2B OTA Indoor & T2F OTA Outdoor-to-Indoor

Over-the-air (OTA) indoor and OTA outdoor-to-indoor timing tests were conducted between antennas mounted within the Laboratory of Building 72C, and between antennas mounted both inside and outside of Building 72C. Cube antennas were connected between Master LocataLite JRC-1, and End-Node LocataLite JRC-2. Indoor OTA tests demonstrated Locata time transfer performance in a short-range indoor environment, while the outdoor-to-indoor OTA tests demonstrated Locata time transfer performance in an environment without line-of-sight. Specifically, Locata timing signals were directed through both the exterior brick wall of Building 72C, and also through a stacked bookcase situated within the Laboratory. An illustrated wiring diagram for the indoor test is shown in Figure 3-5, while the outdoor-to-indoor test is shown in Figure 3-6.

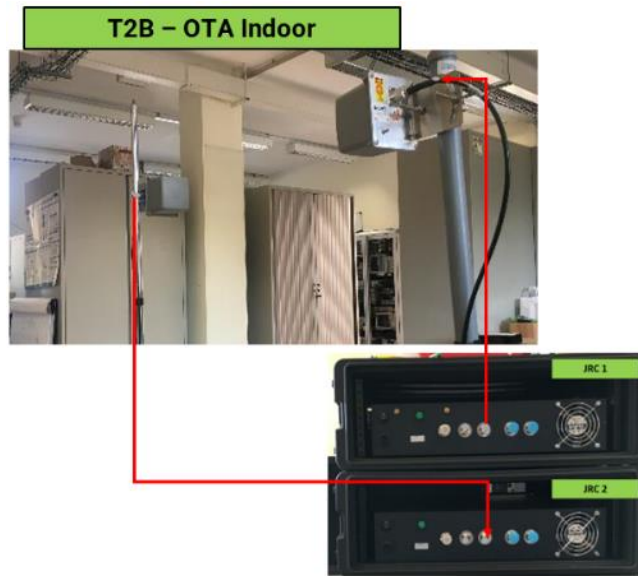

Figure 3-5: T2B OTA Indoor Timing Test Setup

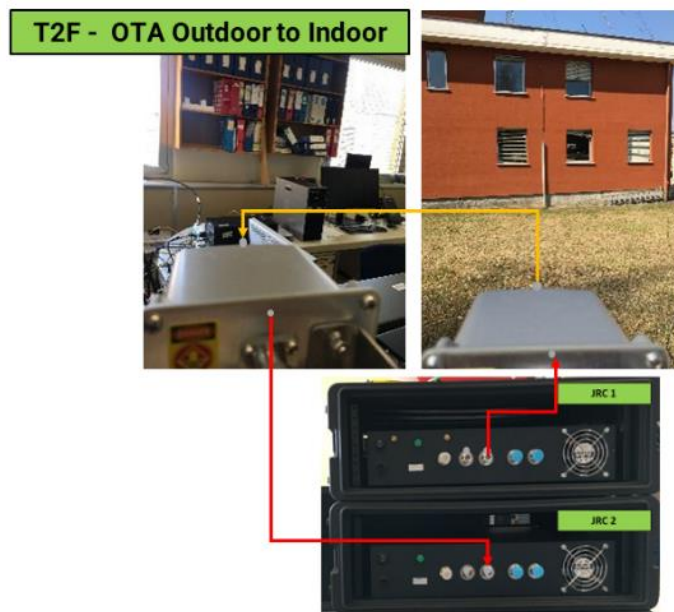

Figure 3-6: T2F OTA Outdoor to Indoor Timing Test Setup

3.2.3 T2C OTA Outdoor Local Area Timing

Local area timing tests were conducted OTA between three sites at JRC; Building 72C (Laboratory), Building 48 (Workshop), and Building 77 (Tower). The local area timing test used the equipment layout shown in Figure 3-7 and comprised four TimeLoc ‘hops’ covering approximately 2km, as shown in Figure 3-8 and Figure 3-9. The Master LocataLite JRC-1 timing signal was transferred via LocataLite Workshop-1, and onto the LocataLite Tower-1. LocataLite Tower-1 then returned the timing signal in a ‘bent-pipe’ configuration back to LocataLite Workshop-2 and onto End-Node LocataLite JRC-2.

Master LocataLite JRC-1 and End-Node LocataLite JRC-2 used one cube antenna each connected via 50m of LMR400UF cable, whereas LocataLites Workshop-1 and Workshop-2 used two cube antennas each connected via 30m of LMR400UF cable. LocataLite Tower-1 used a single dish antenna for both incoming and outgoing time signals connected via 10m of LMR400UF cable, as shown in Figure 3-8.

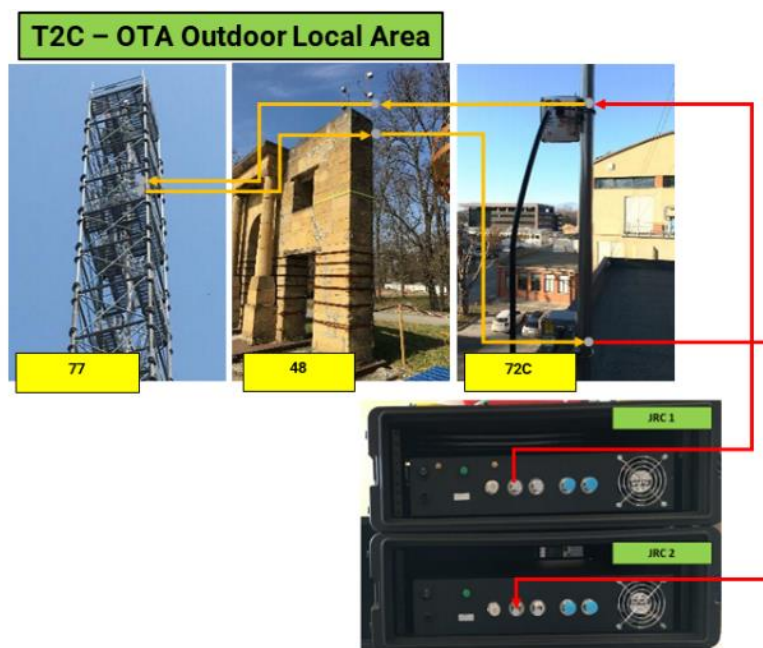

Figure 3-7: T2C OTA Outdoor Local Timing Test Setup

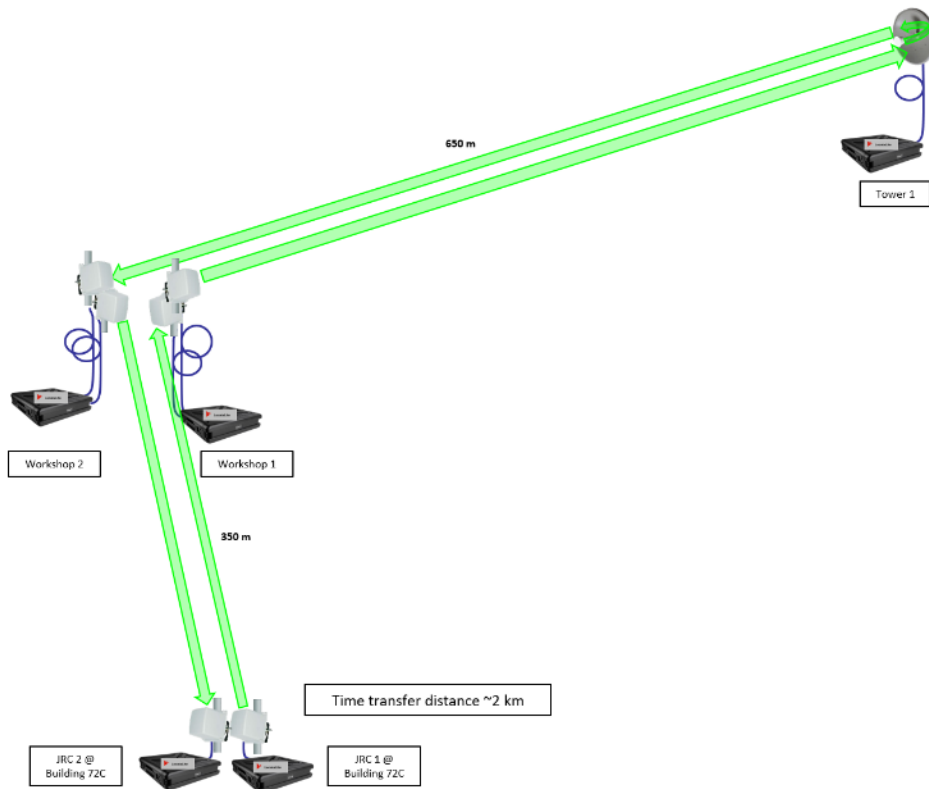

Figure 3-8: T2C OTA Outdoor Local Timing Test Antenna Setup

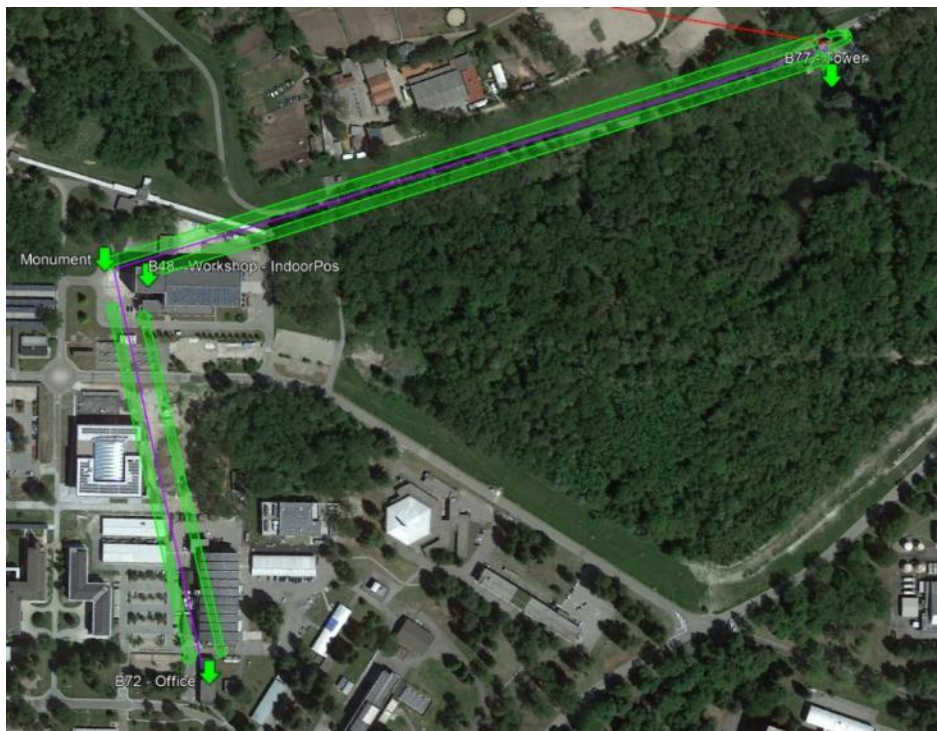

Figure 3-9: T2C OTA Outdoor Local Timing Test Geographical Layout

3.2.4 T2E OTA Outdoor Wide Area Timing

Wide area timing tests were conducted OTA between five sites: Building 72C (Laboratory), Building 48 (Workshop), Building 77 (Tower), Massino Visconti (Mottarone), and Como Brunate (Como). The first three sites were within the JRC premises while the sites Massino Visconti and Como Brunate were remote sites. Linking all sites required eight TimeLoc ‘hops’ using the equipment layout shown in Figure 3-10. The time transfer distance was increased from 2km, covered in the local area test, to 105 km by adding the two LocataLite sites outside of the JRC premises.

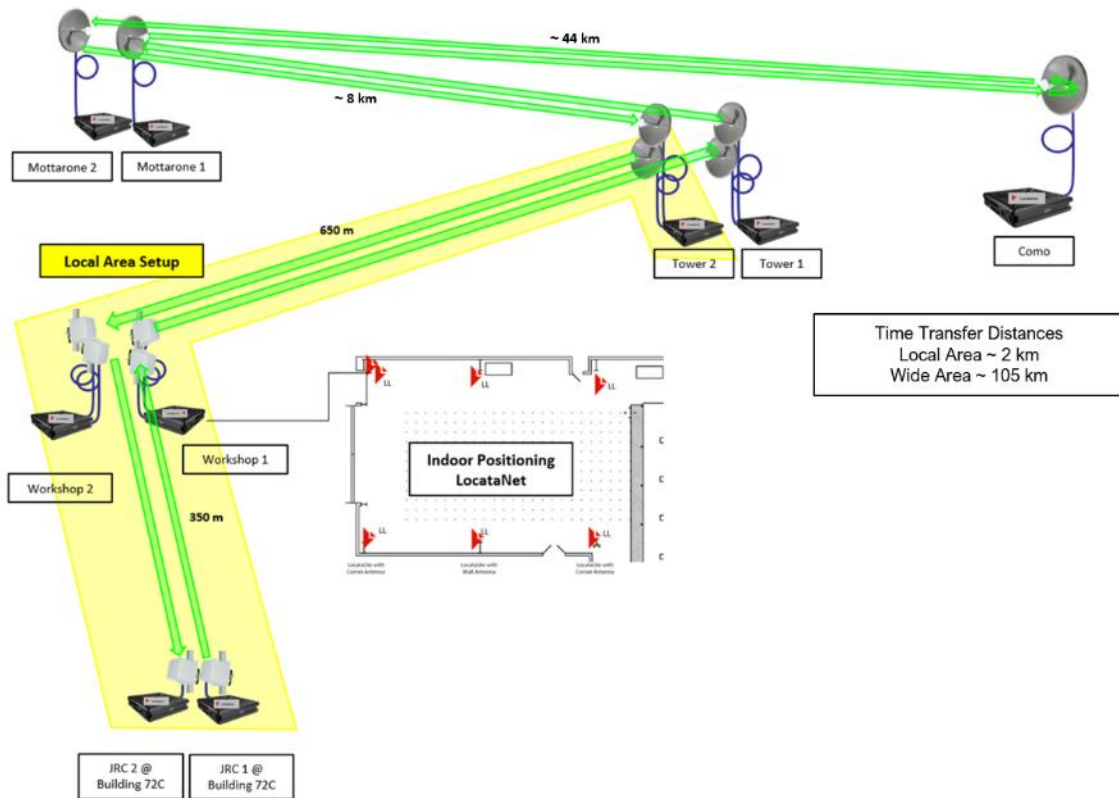

Figure 3-10: T2E OTA Outdoor Wide Area Timing Test – Equipment Layout

Massino Visconti was 8 km West of the JRC tower at latitude 45°49'16.68"N and longitude 8°32'22.95"E. This site incorporated two LocataLites identified as ‘LocataLite Mottarone-1’ and ‘LocataLite Mottarone-2’. The Como Brunate site was 44 km to the East of Massino Visconti, at latitude 45°48'51.91"N and longitude 9° 6'12.48"E. Figure 3-11 shows the location of Massino Visconti and Como Brunate relative to the JRC.



Figure 3-11: Wide Area Sites Massino Visconti, Como Brunate and JRC

LocataLites used for the local area test were reused for the wide area test. LocataLite Tower-1 was remotely reconfigured to transfer the incoming timing signal from LocataLite Workshop-1 to LocataLite Mottarone-1 via a second dish antenna. LocataLite Mottarone-1 then transferred its timing signal to LocataLite Como. This signal was then returned in a 'bent-pipe' configuration via LocataLites Mottarone-2, Tower-2, Workshop-2 and back to End-Node LocataLite JRC- 2.

LocataLites Tower-1 and Tower-2 used two dish antennas each connected via 10m of LMR400UF cable in the configuration shown in Figure 3-2. LocataLite Como used a single dish antenna connected via 5m of LMR400UF cable for both incoming and outgoing time signals. LocataLites Mottarone-1 and Mottarone-2 used one dish antenna each connected via 5m of LMR400UF cable as both Tower and Como LocataLites were within the beam width of the dish antennas used.

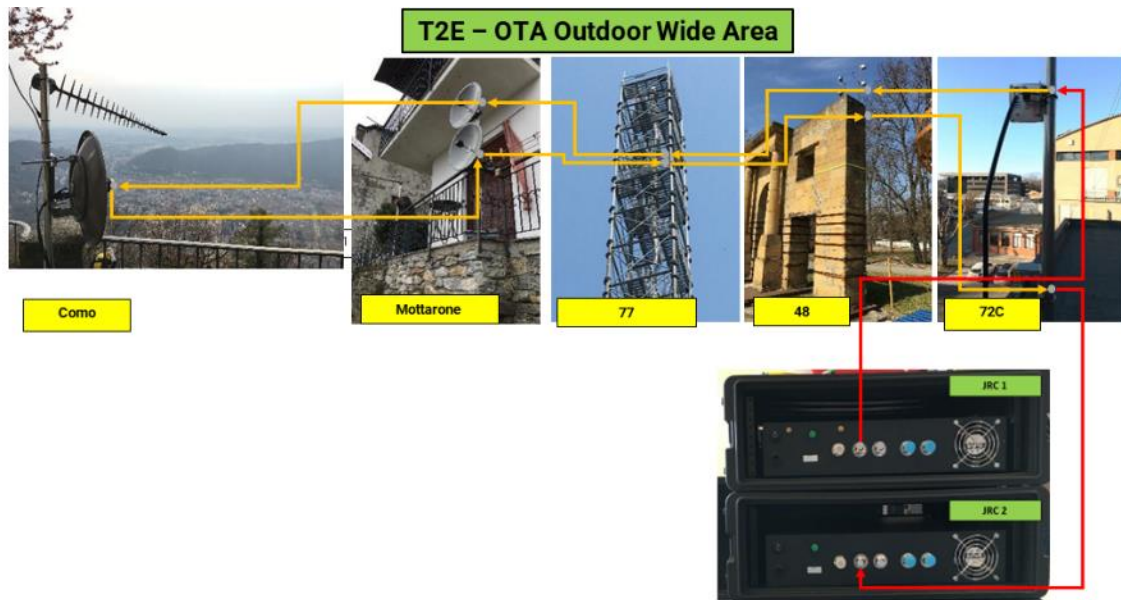

Figure 3-12: T2E OTA Outdoor Wide Area Timing Test Setup

3.2.4.1 Link Power Budget

All LocataLite transmit powers were configured to comply with the ETSI maximum allowed power of +20dBm (EIRP) for the 2.4 GHz band. As an example, for the long-range link between Massino Visconti and Como Brunate the LocataLite transmit powers were configured as shown in the table below.

Site	LocataLite Configured Power (dBm)	Power Measurement @ Input to Antenna *	Antenna Gain (dBi)	LocataLite Transmitted Power EIRP (dBm)
Mottarone-1	10	-0.03	20	19.97
Mottarone-2	10	0.07	20	20.07
Como	9	-0.23	20	19.77

* Includes all RF switch and cable losses between the antenna and the LocataLite

Table 3-3: LocataLite Transmit Power Configuration for the Link Between Massino Visconti and Como

The signal power measurements at the input to the antenna for each LocataLite in the table above were taken using an RF power meter. As can be seen, when the nominal antenna gain of 20 dBi is applied the resulting LocataLite transmitted power was +20dBm (EIRP).

With this power configuration the expected received power over the 43.8 km range is shown in the table below:

Link	LocataLite Transmitted Power EIRP (dBm)	Range (km)	FSPL (dB)	Receiver Antenna Gain (dBi)	Receiver Path Loss *	LocataLite Received Power (dBm)
Mottarone-1 to Como	20	43.8	132.9	20	-6	-98.9

* Includes all RF switch and cable losses between the antenna and the LocataLite

Table 3-4: Link Power Budget for the Link Between Massino Visconti and Como

Note that Mottarone-1 to Como and Como to Mottarone-2 are symmetric links with the same characteristics.

3.2.5 Time Transfer to a Mobile Rover

Locata demonstrated how time may be ‘tapped-off’ from LocataLites in a timing backbone and used to synchronize LocataLites in a positioning network. In this case, LocataLite Workshop-1 acted as an outdoor timing backbone repeater site propagating time from Building 72C to Tower, while also broadcasting positioning signals indoors into the Workshop test area. This illustrates the point-to-multi point time transfer capability of Locata.

LocataLites Indoor 10, 11, 12, 13 and 14 were situated within the Workshop and time synchronized (TimeLoc’d) to LocataLite Workshop-1 thereby transferring UTC time to all LocataLites and Locata Rovers within the Workshop test area. In addition, 10 MHz, 1 PPS, and ToD were available from all LocataLites for use by any co-located electronics that required UTC time.

Timing tests were conducted between LocataLite Workshop-1 and a Locata Rover situated within the Workshop test area. Position Velocity Time (PVT) solutions from the Locata Rover provided PPS and ToD measurements, which were compared to PPS and ToD measurements from LocataLite Workshop-1.

The setup for LocataLite Workshop-1, as shown in Figure 3-13, incorporated four antennas. Antennas 1 and 2 operated as part of the outdoor timing backbone, while antennas 3 and 4 operated as part of the indoor positioning network. The number of antennas and their beam patterns were chosen based on the environment and desired coverage. The complete setup for this test is shown in Figure 3-19.

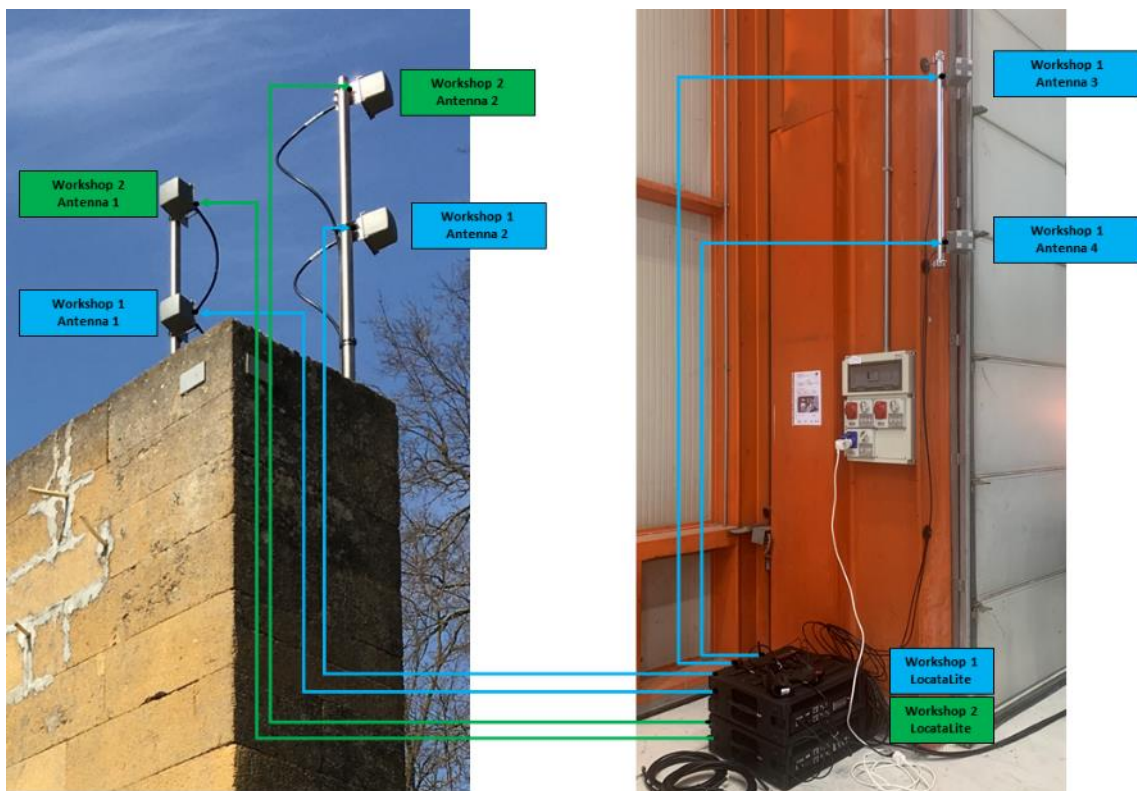

Figure 3-13: Locata Antennas on Building 48 Monument & LocataLites Inside Building 48

3.3 OTA Outdoor Test Sites

This section is an overview of the LocataLite sites and their equipment configurations for T2C OTA Outdoor Local Area and T2E OTA Outdoor Wide Area.

3.3.1 JRC Building 72C (Laboratory)

Antennas for Master LocataLite JRC-1 and End-Node LocataLite JRC-2 were mounted on the roof of Building 72C, specifically in the North-Western corner of the roof handrail, as shown in Figure 3-14. These LocataLites, and other associated equipment were all situated in the Laboratory of Building 72C, as shown in Figure 3-1 and Figure 3-18.

Master LocataLite JRC-1 was equipped with a 4G modem and an external 4G antenna to enable remote access. The 4G antenna was also mounted on the roof of Building 72C and oriented towards the nearest cell tower. Ethernet cables between Master LocataLite JRC-1, End-Node LocataLite JRC-2 and Laptop-1 provided remote access for all co-located devices at this site using the one 4G connection.



Figure 3-14: Building 72C Installation

3.3.2 JRC Building 48 (Workshop)

This site included Locata equipment for both time transfer and indoor positioning tests. Equipment setup at this site for indoor positioning tests are described in section 4.2.1 Test Equipment.

The JRC team mounted LocataLite Workshop-1 and LocataLite Workshop-2 antennas on the monument to the West of the Building 48 (Workshop). These antennas are shown in Figure 3-13. LocataLites Workshop-1 and Workshop-2 were placed inside the Workshop.

LocataLite Workshop-1 was equipped with a 5 GHz Wi-Fi access point, a 4G modem and an external 4G antenna to enable remote access. The 4G antenna was mounted near the monument and oriented towards the nearest cell tower. A 5 GHz Wi-Fi access point at LocataLite Workshop-1 provided remote access for all co-located devices at this site using the one 4G connection. This included LocataLite Workshop-2, LocataLites Indoor 10, 11, 12, 13, 14, the Locata Rover and Laptop-2.

3.3.3 JRC Building 77 (Tower)

LocataLite Tower-1 and LocataLite Tower-2 were mounted on the JRC Tower (Building 77) at a height of 80 m, as shown in Figure 3-15. This height was chosen to meet JRC installation requirements whilst guaranteeing a clear line-of-sight between the Workshop and the Tower antennas.

LocataLite Tower-1 was equipped with a 4G modem and an external 4G antenna to enable remote access. The 4G antenna was also mounted on the JRC Tower and oriented towards the nearest cell tower. LocataLite Tower-2 shared this 4G connection via an ethernet cable.



Figure 3-15: Tower Installation

3.3.4 Massino Visconti (Mottarone)

A rental property at Massino Visconti was leased for the OTA outdoor wide area timing test T2E. The two LocataLites situated at Massino Visconti were named after the nearby mountain 'Mottarone'.

LocataLite Mottarone-1 and LocataLite Mottarone-2 incorporated dish antennas mounted to the balcony railing of the rental property with line-of-sight to both JRC Tower (approximately 8 km away) and Como Brunate (approximately 44 km away). The installation is shown in Figure 3-16.

LocataLite Mottarone-1 was equipped with a 4G modem and an external 4G antenna to enable remote access. The 4G antenna was also mounted to the balcony railing and oriented towards the nearest cell tower. LocataLite Mottarone-2 shared this 4G connection via an ethernet cable.



Figure 3-16: Massino Visconti (Mottarone)

3.3.5 Como Brunate

A rental property at Como Brunate was leased for the OTA outdoor wide area timing test T2E. The LocataLite situated at Como Brunate was named after the nearby township of 'Como'.

LocataLite Como was the furthest site in the wide area test setup with approximately 44km to Massino Visconti. The single dish antenna shown in Figure 3-17 established links to both LocataLite Mottarone-1 and LocataLite Mottarone-2.

LocataLite Como was equipped with a 4G modem and an external 4G antenna to enable remote access. The 4G antenna was mounted above the dish antenna and oriented down towards the nearest cell tower.



Figure 3-17: Como Brunate

3.4 Test Setup & Measurement Method

3.4.1 Time Transfer Between LocataLites

3.4.1.1 Laboratory Test Setup

The Laboratory test setup located in Building 72C consisted of the following equipment, as shown in Figure 3-18:

- JRC UTC Reference Clock
- Locata UTC Time Standard
- Master LocataLite JRC-1
- End-Node LocataLite JRC-2
- Time Interval Counters
- Laptop

The JRC UTC Reference clock comprised a Stanford Research Systems FS740 GNSS disciplined Rubidium time standard with Meinberg SDU PPS distribution. The Locata UTC Time Standard comprised a Microchip SyncServer S650 disciplined from a Ball Efratom MRK Rubidium time standard. The Efratom provided a stable 10MHz clock to the S650 whilst in holdover. The S650 provided 10 MHz, 1 PPS, and Time of Day (ToD) to the Master LocataLite JRC-1. Various time transfer media were configured between Master LocataLite JRC-1 and End-Node LocataLite JRC-2. Keysight 53230A Time Interval Counters were configured to measure Locata internal, external, and UTC time transfer performance. The laptop was configured to log ToD messages.

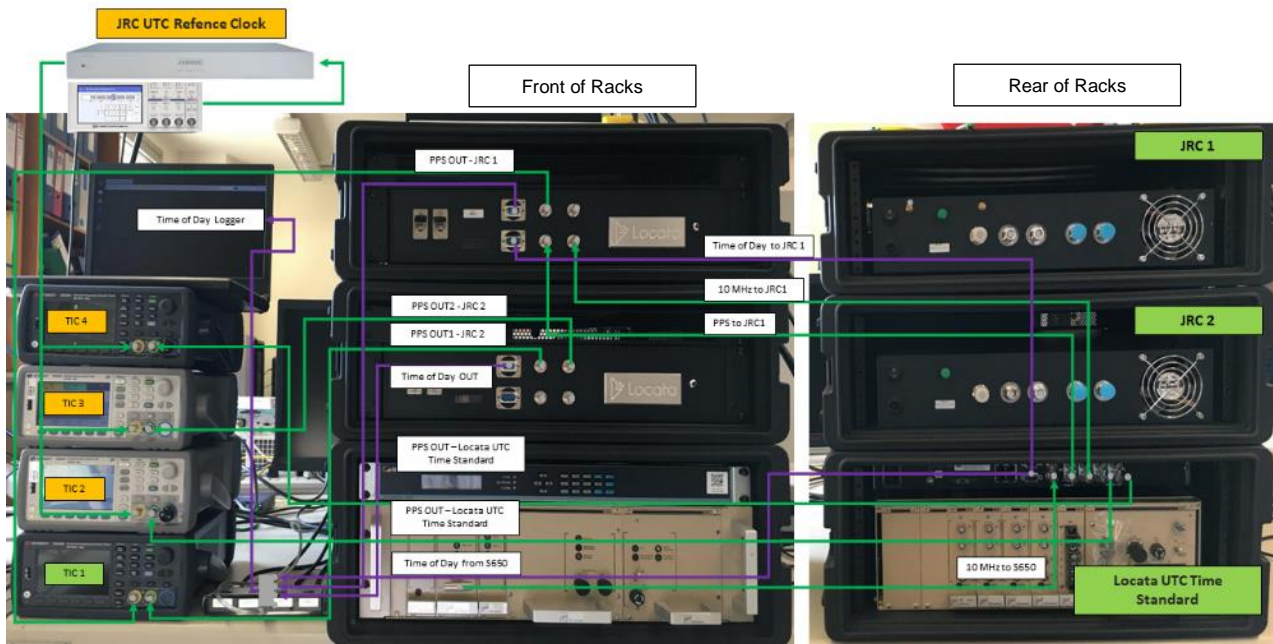

Figure 3-18: UTC Stability & Time Transfer Performance Test Method

3.4.1.2 Laboratory Test Equipment

1. JRC UTC Reference Clock
 - SRS FS740 (GNSS disciplined Rubidium time standard)
 - Meinberg SDU (PPS distribution)
2. Locata UTC Time Standard
 - Ball Efratom MRK (Rubidium time standard)
 - Microchip SyncServer S650 (ToD, PPS, and 10MHz distribution, disciplined from the Ball Efratom Rubidium)
3. LocataLites
 - Master LocataLite (JRC-1)
 - End-Node LocataLite (JRC-2)
4. Time Interval Counters – Keysight 53230A
 - TIC 1 – Master LocataLite (JRC-1) to End-Node LocataLite (JRC-2) - Locata Internal Time Transfer
 - TIC 2 – JRC UTC Reference (FS740) to Locata UTC Time Standard (S650) - Clock Comparison
 - TIC 3 – JRC UTC Reference (FS740) to End-Node LocataLite (JRC-2) – JRC UTC to Locata UTC Comparison
 - TIC 4 – Duplicate of TIC 2 for Locata remote monitoring only
5. Laptop - ToD NMEA ZDA data logging via serial RS-232 ports.

3.4.1.3 Measurement Method

Short term clock stability & time transfer performance periods of 24 hours were conducted for tests T2A to T2F.

Measurements included using Time Interval Counters (TICs) to measure PPS outputs between devices, logging Time of Day (ToD) serial messages to verify time reporting at the correct 1s boundary, and logging Locata Binary Messaging Protocol (LBMP) messages to show link measurement adjustments over each test duration. Device web page screenshots were also taken at several points throughout testing.

Three Time Interval Counters (TICs) were used to assess Locata internal, external, and UTC time transfer performance as follows:

1. TIC 1 – Master LocataLite (JRC-1) to End-Node LocataLite (JRC-2) - providing Locata internal time transfer performance, independent of any external clocks.
2. TIC 2 – JRC UTC Reference (FS740) to Locata UTC Time Standard (S650) - providing the time difference between the JRC UTC reference clock and the Locata UTC Time Standard.
3. TIC 3 – JRC UTC Reference (FS740) to End-Node LocataLite (JRC-2) - providing the time difference between the JRC UTC reference clock and the Locata transferred UTC time.
4. TIC 2 differenced from TIC 3 providing Locata external time transfer performance (including internal time transfer). This is equivalent to having a dedicated TIC measuring the PPS output of Locata UTC Time Standard (S650) to the PPS output of End-Node LocataLite (JRC-2).
5. TIC 1 differenced from point 4 above (Locata external time transfer performance) providing external time synchronization performance. This is equivalent to having a dedicated TIC measuring the PPS output of Locata UTC Time Standard (S650) to the PPS output of Master LocataLite (JRC-1).

The above measurement methodology was used for all time transfer test scenarios, apart from the time transfer to a mobile rover, which is discussed later in this section.

The Locata UTC Time Standard (S650) was initially synchronized to UTC time via GNSS, then placed into holdover disciplined from the Efratom Rubidium. All tests were conducted in this holdover configuration. Due to the relatively slow drift rate of the Efratom, resynchronization to GNSS was not necessary for each test case to meet the 1us specification. The following table shows when resynchronization was performed.

Test	GNSS Resynchronization Performed Immediately Before Test
T2A Coax Cable	No
T2B OTA Indoor	Yes
T2C OTA Outdoor Local Area	Yes
T2D Fibre Optic 1km	Yes
T2E OTA Outdoor Wide Area	No
T2F OTA Outdoor to Indoor	No
T2G Time Transfer to a Mobile Rover	No

Table 3-5: Locata UTC Time Standard GNSS Resynchronization

Locata UTC time transfer was heavily influenced by the performance of the Rubidium time standard used. Locata time transfer performance was always at the sub-nanosecond level, whereas the Rubidium based Locata UTC Time Standard was observed during some tests to drift 100's of nanoseconds. All clocks – including atomic clocks – drift over time. The End-Node LocataLite JRC-2 followed this drift, even as the Master LocataLite JRC-1 and the End-Node LocataLite JRC-2 remained tightly synchronized to the Locata UTC Time Standard.

Time of Day (ToD) messages from the Locata UTC Time Standard (S650), Master LocataLite JRC-1 and End-Node LocataLite JRC-2 were logged by a laptop via serial ports using the GIS application 'QGIS'. QGIS ran a proprietary Locata plugin to display and log incoming NMEA ZDA messages. Each received message was logged with a SW timestamp of reception, with sub-second resolution. A comparison of ZDA message content and the timestamp of reception was used to validate the synchronization of ToD ZDA messages.

Locata Binary Messaging Protocol (LBMP) messages were logged to internal disk of each LocataLite. LBMP messages contained information on device status, signal tracking, and TimeLoc. Post-processing scripts were used to extract Measured Link Adjustment results.

LBMP content was also published on device web pages with each HTML request. Web page snapshots were taken during testing to capture what an operator would see when interacting with a LocataLite.

3.4.1.4 TimeLoc Link Adjustments

Measured link adjustments represent the continuous corrections applied within the TimeLoc process to time synchronize a pair of LocataLites. They also represent the complete range over which Locata signals propagate between the pair of LocataLites. This includes all interconnecting cables, connectors, antennas, and the transmission medium itself (over the air, coax, or fibre optic). In the case of over-the-air, the signal propagation path between a pair of antennas is a combination of direct line-of-sight and any multipath components. As a result, the range values of measured link adjustments will not simply be the geometric range separating each pair of antennas.

The signal propagation delay, and hence propagation range, through every element in the path of propagation is subject to variations due to environmental changes. These changes include tropospheric delay affecting over-the-air transmission and temperature variations affecting coax and fibre optic cables. TimeLoc continuously and autonomously measures the link range and adjusts for any changes to counter these variations, ensuring that time transfer is not perturbed.

Logged measured link adjustments provided an indication of how much compensation was applied over each test.

3.4.2 Time Transfer to a Mobile Rover

3.4.2.1 Workshop Test Setup

LocataLite Workshop-1 operated as the TimeLoc reference for the Indoor LocataLites 10, 11, 12, 13 and 14. The Locata Rover used signals from all the LocataLites broadcasting into the Workshop to produce a PVT solution. A Time Interval Counter was connected between LocataLite Workshop-1 and Locata Rover PPS outputs to measure the timing performance of the Locata Rover. Time of Day messages from both LocataLite Workshop-1 and the Locata Rover were logged using serial ports on Locata Laptop. A diagram of the Workshop setup is shown in Figure 3-19 while annotated pictures are shown in Figure 3-20.

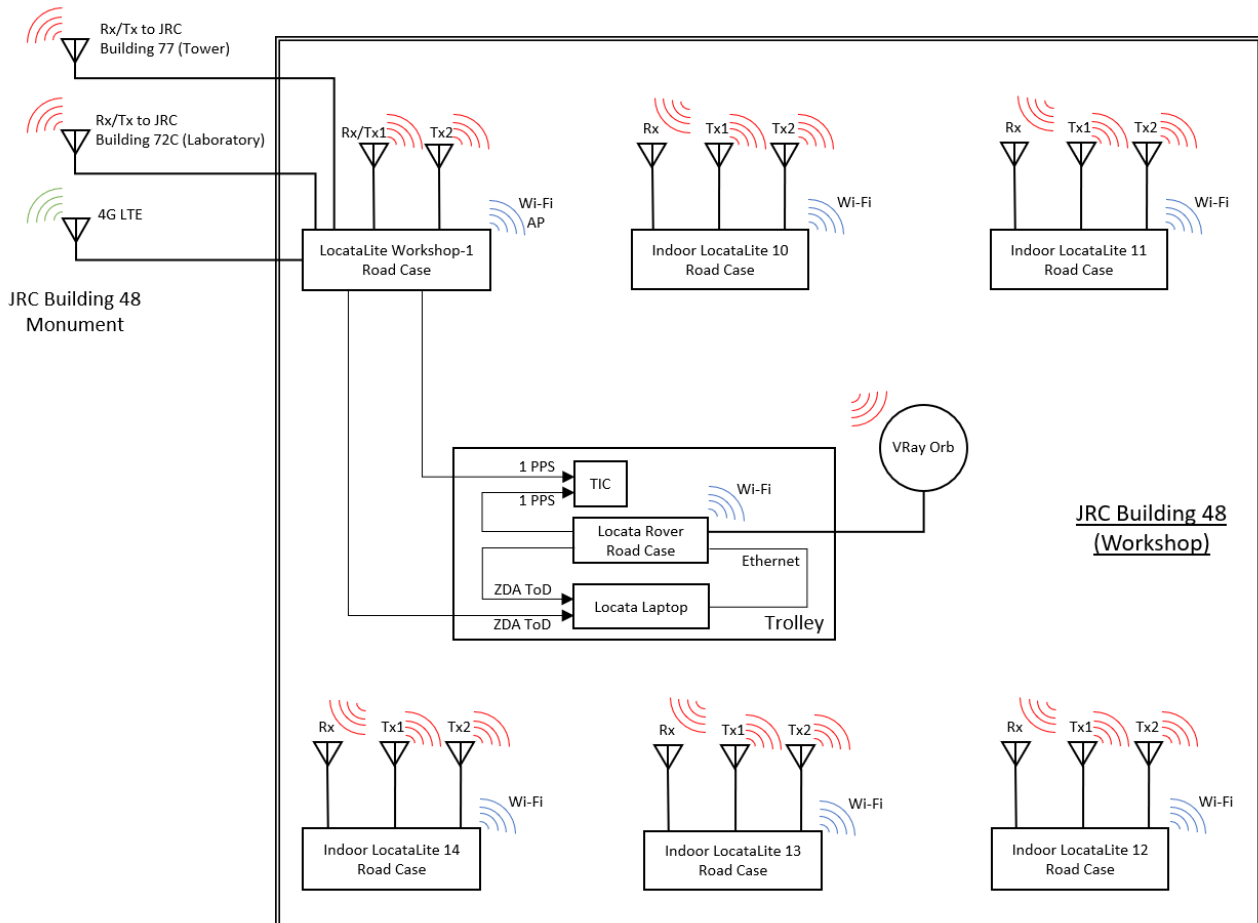

Figure 3-19: Diagram of Workshop Setup for Measurement of Time Transfer to a Mobile Rover

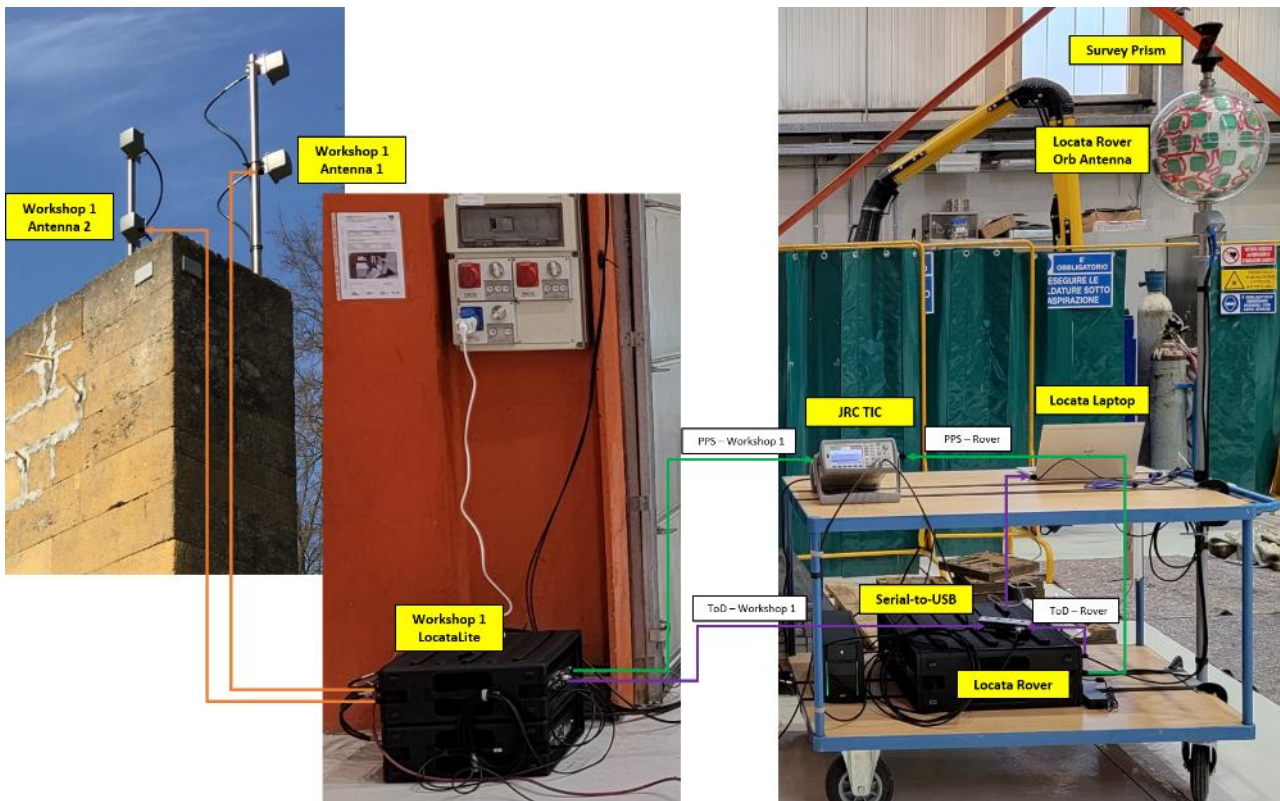

Figure 3-20: Setup for measurement of time transfer to a mobile rover

3.4.2.2 Workshop Test Equipment

1. LocataLites
 - LocataLite Workshop-1, which propagated UTC Time and broadcast positioning signals into the workshop
 - LocataLites Indoor 10, 11, 12, 13 and 14, which provided positioning signals to the Locata Rover
2. Rover
 - Produced position, velocity, and time (PVT) solutions
3. Time Interval Counter – Keysight 53220A
 - TIC 1 – LocataLite Workshop-1 to Locata Rover
4. Laptop
 - Logged Workshop-1 and Locata Rover ToD messages in the form of NMEA ZDA.

3.4.2.3 Measurement Method

The Locata Rover was initialized and positioned near LocataLite Workshop-1 for PPS comparison. A Keysight 53220A TIC compared 1PPS from Workshop-1 and 1PPS from the Locata Rover. Serial connections from Workshop-1 and the Locata Rover were connected to a laptop for ToD comparison. Logging of both Locata NMEA data and TIC data was manually started upon a countdown.

The short term clock stability & time transfer performance period was limited to a 4 hour test period due to Workshop access restrictions (it's a working facility for JRC fabrication engineering and testing).

3.5 Measurement Data Processing

Post processing of all timing data was performed with various python scripts. All raw data, python processing script, and all script outputs (plots and CSV) were provided to the JRC for full traceability of results.

Refer to the D220 Test Technical Notes document for further details.

3.5.1 TIC Logs

TIC data was logged by JRC's remote logging utility for most of the tests. The exceptions to this were in the following tests in which a single TIC was configured to log to its internal disk:

- T2E – OTA Outdoor Wide Area, measuring Master LocataLite (JRC-1) to End-Node LocataLite (JRC-2) – Locata Internal Time Transfer
- T2G – Time Transfer to a Mobile Rover, measuring Source LocataLite (Workshop-1) to Locata Positioning Device (Rover).

The JRC remote logging utility generated TIC log files at hourly intervals in a CSV format with Epoch/Unix timestamp and other meta data for each sample. In contrast, TIC samples logged to internal disk included just the samples (single column) all in one file with the filename suffix containing the start time of the log. For the above tests the internally logged TIC data file was copied off and formatted according to the file generated by the JRC's remote logging utility to facilitate processing.

In all tests, the three TICs measured the following:

1. TIC 202 - Master LocataLite (JRC-1) to End-Node LocataLite (JRC-2) - Locata Internal Time Transfer
2. TIC 214 - JRC UTC Reference (FS740) to Locata UTC Time Standard (S650) - Clock Comparison
3. TIC 215 - JRC UTC Reference (FS740) to End-Node LocataLite (JRC-2) – JRC UTC to Locata UTC Comparison

From these the following values were extrapolated:

4. TIC 214 differenced from TIC 215 to provide Locata External Time Transfer, equivalent to measuring the PPS output of Locata UTC Time Standard (S650) to the PPS output of End-Node LocataLite (JRC-2).
5. TIC 202 differenced from point 4 above to provide Locata External Time Synchronization, equivalent to measuring the PPS output of Locata UTC Time Standard (S650) to the PPS output of Master LocataLite (JRC-1).

TIC logs were processed with python scripts that performed the following:

- Combine hour-long TIC logs into one continuous log, as required.
- Trim logs to the required time interval for each test.
- Calculate the extrapolated values by differencing as described above.
- Compute required statistics on each measurement set for the test interval.
- Generate plots with tables showing the complete measurement set and statistics for the test interval.
- Generate CSV output of the complete measurement set trimmed to the test interval.

3.5.2 Locata Logs

In all tests Locata devices logged to their internal disk in the proprietary LBMP binary format.

Relevant data from each test was decoded using LBMP parser tools and post processed using python and shell scripts that performed the following:

- Combine multiple LBMP logs into one continuous log, as required.
- Trim logs to the required time interval for each test.
- Extract the measured link range adjustment.
- Calculate total measured link range adjustment for multi-hop test cases.
- Compute required statistics on each data set for the test interval.
- Generate plots with tables showing the complete data set and statistics for the test interval.
- Generate CSV output of the complete data set trimmed to the test interval.

An LBMP parser tool was made available to JRC on request.

3.5.3 Time of Day Logs

Synchronization of the serial ZDA ToD messages from LocataLites JRC-1 and JRC-2 were verified against the Locata UTC Time Standard (S650) using a python script that performed the following:

- Trim logs to the required time interval for each test.
- Match the time content of each message to ensure there were no differences, and
- Calculate the difference in the timestamp of message reception to ensure the messages were received at the correct second boundary.

3.6 Test Cases

This section includes the setup instructions for all the timing test cases.

3.6.1 System Verification – T1

Test ID	T1
Test Name	System verification
Objective	Setup DUT and verify that it is operating correctly
Output	DUT is ready
Time to execute	< 30 min (after clocks are stabilized & LocataLites are in TimeLoc)
Metrics	Pass / Fail

Setup

1. Stabilize reference and test clocks.
2. Setup JRC-1 & JRC-2 LocataLites, clocks, and Time Interval Counters (TICs) as shown in Figure 3-18).
3. Connect JRC-1 and JRC-2 LocataLites using a coax cable.
4. Wait for JRC-1 & JRC-2 LocataLites to TimeLoc.
5. Free run clocks and verify that TICs are recording the data correctly.

3.6.2 Timing Over Copper – T2A

Test ID	T2A
Test Name	Short term clock stability & time transfer performance - Copper/coax cable
Objective	To assess the clock stability & time transfer performance of Locata over copper/coax cable
Output	PPS + ToD (NMEA ZDA) + LBMP (Locata Binary Messaging Protocol)
Time to execute	24 hrs
Metrics	Number of Samples, Mean, Peak to Peak, Standard Deviation, 3-Sigma, Maximum Time Interval Error, Allan Variance (AVAR, OAVAR, MVAR), Allan Deviation (ADEV, OADEV, MDEV)

Setup

1. Execute T1.
2. Run test for 24 hrs monitoring performance.

3.6.3 Timing OTA Indoor – T2B

Test ID	T2B
Test Name	Short term clock stability & time transfer performance - OTA indoor
Objective	To assess the clock stability & time transfer performance of Locata over-the-air indoor
Output	PPS + ToD (NMEA ZDA) + LBMP (Locata Binary Messaging Protocol)
Time to execute	24 hrs
Metrics	Number of Samples, Mean, Peak to Peak, Standard Deviation, 3-Sigma, Maximum Time Interval Error, Allan Variance (AVAR, OAVAR, MVAR), Allan Deviation (ADEV, OADEV, MDEV)

Setup

1. Execute T1 using indoor antenna pair instead of coax cable in step (3).
2. Run test for 24 hrs monitoring performance.

3.6.4 Timing OTA Outdoor Local Area – T2C

Test ID	T2C
Test Name	Short term clock stability & time transfer performance - OTA outdoor local area
Objective	To assess the clock stability & time transfer performance of Locata over-the-air outdoor – time transfer over 2 km
Output	PPS + ToD (NMEA ZDA) + LBMP (Locata Binary Messaging Protocol)
Time to execute	24 hrs
Metrics	Number of Samples, Mean, Peak to Peak, Standard Deviation, 3-Sigma, Maximum Time Interval Error, Allan Variance (AVAR, OAVAR, MVAR), Allan Deviation (ADEV, OADEV, MDEV)

Setup

1. Execute T1 using outdoor local area configuration instead of coax cable in step (3).
2. Run test for 24 hrs monitoring performance.

3.6.5 Timing Over Fibre - T2D

Test ID	T2D
Test Name	Short term clock stability & time transfer performance - Fibre optic
Objective	To assess the clock stability & time transfer performance of Locata over fibre optic
Output	PPS + ToD (NMEA ZDA) + LBMP (Locata Binary Messaging Protocol)
Time to execute	24 hrs
Metrics	Number of Samples, Mean, Peak to Peak, Standard Deviation, 3-Sigma, Maximum Time Interval Error, Allan Variance (AVAR, OAVAR, MVAR), Allan Deviation (ADEV, OADEV, MDEV)

Setup

1. Execute T1 using fibre optic cable instead of coax cable in step (3).
2. Run test for 24 hrs monitoring performance.

3.6.6 Timing OTA Outdoor Wide Area – T2E

Test ID	T2E
Test Name	Short term clock stability & time transfer performance - OTA outdoor wide area
Objective	To assess the clock stability & time transfer performance of Locata over-the-air outdoor – time transfer over 105 km
Output	PPS + ToD (NMEA ZDA) + LBMP (Locata Binary Messaging Protocol)
Time to execute	24 hrs
Metrics	Number of Samples, Mean, Peak to Peak, Standard Deviation, 3-Sigma, Maximum Time Interval Error, Allan Variance (AVAR, OAVAR, MVAR), Allan Deviation (ADEV, OADEV, MDEV)

Setup

1. Execute T1 using T2E OTA Outdoor Wide Area Timing configuration instead of coax cable in step (3).
2. Run test for 24 hrs monitoring performance.

3.6.7 Timing OTA Outdoor to Indoor– T2F

Test ID	T2E
Test Name	Short term clock stability & time transfer performance - OTA Outdoor to Indoor
Objective	To assess the clock stability & time transfer performance of Locata over-the-air without direct line-of-sight
Output	PPS + ToD (NMEA ZDA) + LBMP (Locata Binary Messaging Protocol)
Time to execute	24 hrs
Metrics	Number of Samples, Mean, Peak to Peak, Standard Deviation, 3-Sigma, Maximum Time Interval Error, Allan Variance (AVAR, OAVAR, MVAR), Allan Deviation (ADEV, OADEV, MDEV)

Setup

1. Execute T1 using outdoor to indoor antenna pair instead of coax cable in step (3).
2. Run test for 24 hrs monitoring performance.

3.6.8 Time Transfer to a Mobile Rover – T2G

Test ID	T2E
Test Name	Short term clock stability & time transfer performance – Mobile Rover
Objective	To assess the clock stability & time transfer performance of a Locata Rover performing a PVT solution
Output	PPS + ToD (NMEA ZDA) + LBMP (Locata Binary Messaging Protocol)
Time to execute	4 hrs
Metrics	Number of Samples, Mean, Peak to Peak, Standard Deviation, 3-Sigma, Maximum Time Interval Error, Allan Variance (AVAR, OAVAR, MVAR), Allan Deviation (ADEV, OADEV, MDEV)

Setup

1. Setup the indoor LocataLites to time synchronize to LocataLite Workshop-1.
2. Converge the Rover solution.
3. Ensure the TIC is measuring PPS from Rover and LocataLite Workshop-1.
4. Run test for 4 hrs monitoring performance.

4 Positioning Tests

Locata positioning tests were designed to show Locata technology’s capability to position a Locata Rover with centimetre-level accuracy in a variety of environments and operating conditions. Locata showed these capabilities at two different sites. Firstly, in an industrial test facility at a Locata customer in Düsseldorf, Germany where fully-automated port machines are manufactured and tested prior to deployment in commercial ports around the world. Secondly, in an extremely “multipath-rich” indoor space in the JRC Building 48 (Workshop).

4.1 Test Overview

The main objective of these tests was to assess positioning accuracy of Locata technology compared against a GNSS and/or Total Station reference (references vary depending on the test case; please see test scenario descriptions for details).

Shown in Table 4-1 is the summary of positioning test scenarios.

Test ID/ Name, Location	Output	Date, Duration & Method	Metrics
T1 System verification	DUT is ready	Day 1 of all tests < 30 min (test time) - setup validation only	Pass / Fail
Operational Environments T6A – Outdoor static (GNSS & Total Station as references)	PVT (NMEA & LBMP)	April 6, 2022 Düsseldorf, Germany 58 static points dwelling at least 1 minute per point.	Boxplot per point (T6A)
T6B – Outdoor kinematic (GNSS as reference)		6 routes with 2 to 4 repeats each.	CDF of 2D difference against GNSS (T6B)
Indoor Positioning T7A – Indoor static (Total Station as references)	PVT (NMEA & LBMP)	March 10, 2022 JRC Ispra 7 static points (several different test runs chosen from a total of 23 possible points pre-surveyed into Building 48 indoor area by the JRC researchers) - dwelling for at least 1 minute per point. Reoccupy same points in reverse.	Boxplot per point (T7A)
T7B – Indoor kinematic (Total Station as reference)		North-South and East-West routes with at least 2 repeats.	CDF of cross-track error against Total Station (T7B)

Table 4-1: Positioning Test Case Summary

4.2 Test Setup & Measurement Method

4.2.1 Test Equipment

This section is a review all the test equipment used in the positioning tests.

4.2.1.1 LocataLites in Positioning Configuration for JRC Workshop

The Indoor Positioning Tests were conducted inside JRC Building 48 (Workshop).

In this test, six LocataLites were installed as shown in Figure 4-1. These were LocataLites Workshop-1 and LocataLites Indoor 10, 11, 12, 13 and 14. Workshop-1 acted as the TimeLoc reference for the indoor LocataLites, whilst also functioning as part of the outdoor time transfer backbone. This setup is equivalent to test T2G Time Transfer to a Mobile Rover and is described in Section 3.2.5.

LocataLites configured for positioning use two transmit antennas (Tx1 and Tx2) and one receive antenna (Rx). Signals broadcast from antennas Tx1 and Tx2 are used by Locata Rovers for positioning and may also be used by other LocataLites for TimeLoc. Each LocataLite receive antenna allows a LocataLite to perform both TimeLoc and LocataNet monitoring functions.

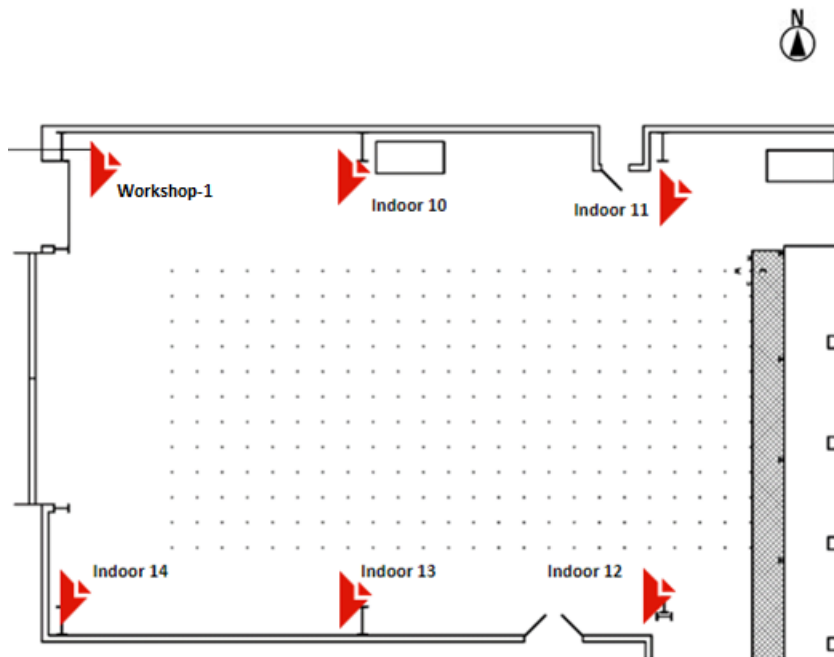

Figure 4-1: LocataNet in Building 48 (Workshop)

The type of antennas used by a LocataLite depends on the service environment. For instance, Figure 4-2 shows the LocataLite antenna configuration that was used for 180° coverage along the walls of the Workshop. The top antenna is the Rx while the bottom two are Tx1 and Tx2 respectively.

Figure 4-3 shows the LocataLite antenna configuration that was used when 90° coverage was required at the corners of the Workshop. The middle antenna is the Rx while the top and bottom are Tx1 and Tx2 respectively.



Figure 4-2: LocataLite with Indoor Wall (180° Coverage) Antennas

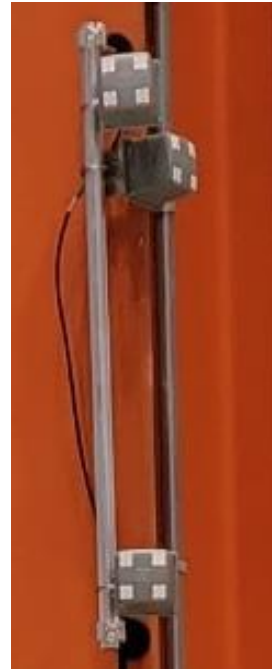

Figure 4-3: LocataLite with Indoor Corner (90° Coverage) Antennas

LocataLite Workshop-1

Figure 3-13 shows antenna setups for LocataLites Workshop-1 and Workshop-2. LocataLite Workshop-2 is part of the timing test setup and not a part of the indoor positioning setup.

LocataLite Workshop-1 broadcast from two indoor antennas for positioning and two outdoor antennas as part of the timing backbone.

Other Indoor LocataLites

LocataLites Indoor 10 and 13 were connected to antennas arranged in Wall Configuration (Figure 4-2) whereas LocataLites Indoor 11, 12, and 14 were connected to antennas in Corner Configuration (Figure 4-3).

4.2.1.2 LocataLites in Positioning Configuration for Outdoor Testing

The outdoor positioning tests were conducted at a Locata customer site in Düsseldorf, Germany. This is the product validation test site of Konecranes, the world's largest port machinery manufacturer. This site uses LocataLite antennas that are designed for container terminals (e.g. ports and logistics parks) and other harsh industrial environments. These antennas are typically mounted at or above 20 m from the ground at ports to fit the visibility needs of Locata Rovers on automated straddle carrier machines known as A-Strads^[7]. Shown in Figure 4-4 is the Locata antenna setup that was available at the Konecranes Düsseldorf test site. In this antenna configuration, the Rx antenna is setup at the top coupled with Tx1 and the Tx2 element is spatially separated by 1.5 m.

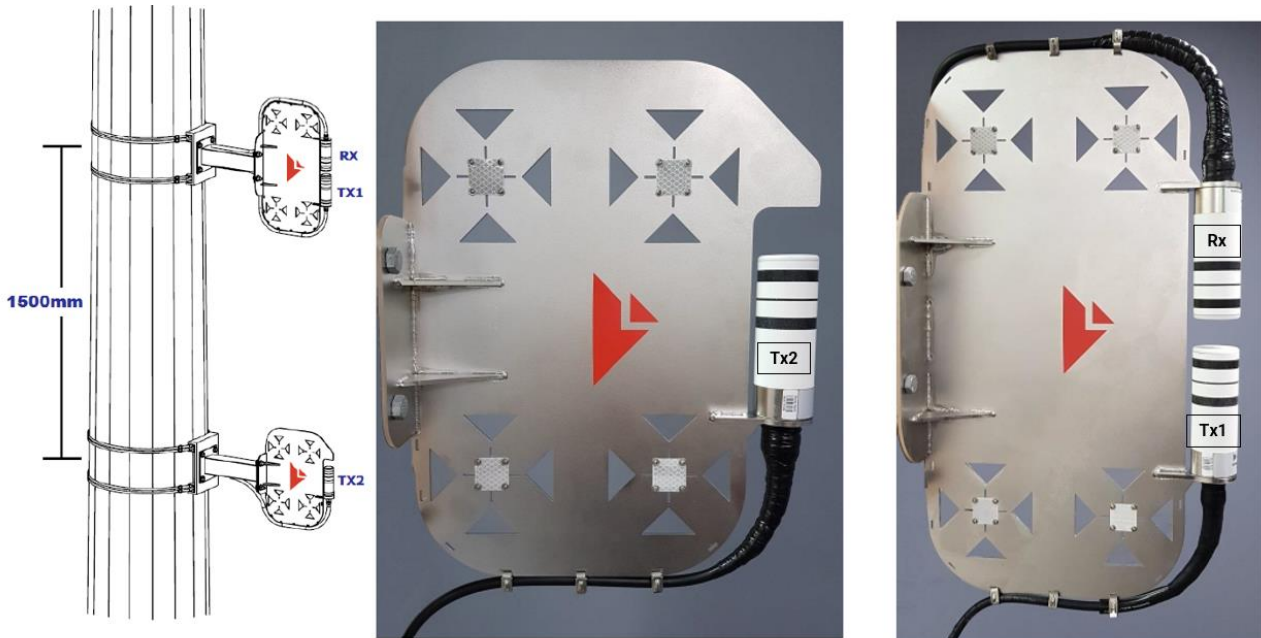

Figure 4-4: LocataLite with 270° Coverage Antennas at the Locata Outdoor Positioning Test Site

4.2.1.3 Locata Rovers

Locata Rovers track LocataLite signals and output precise Position, Velocity, and Time (PVT) solutions. The Locata Rovers and their VRay Orb antennas used for the outdoor tests (T6) were integrated and manufactured as standard equipment onto the Konecranes A-Strads by Konecranes. For the indoor tests (T7) Locata set up a Rover with a VRay Orb antenna on a JRC supplied Test Trolley.

^[7] Konecranes Noell Automated Straddle Carrier: <https://www.youtube.com/watch?v=4QOsSFaHZ3w>

4.2.1.4 Locata Rover in Outdoor Tests - T6

Locata is the core positioning technology used by Konecranes for A-Strad navigation. Each A-Strad has two Locata Rovers positioned at either end of the machine, and each Rover is connected to their respective VRay Orb antenna. The dual Rover/dual VRay configuration allows the A-Strad to precisely determine position and orientation of the machine.

Figure 4-5 shows the equipment used by Locata to demonstrate Locata performance against Total Station and GNSS references. This included adding a co-centrally mounted survey prism and a GNSS antenna which enables the capture of reference Total Station and GNSS data.

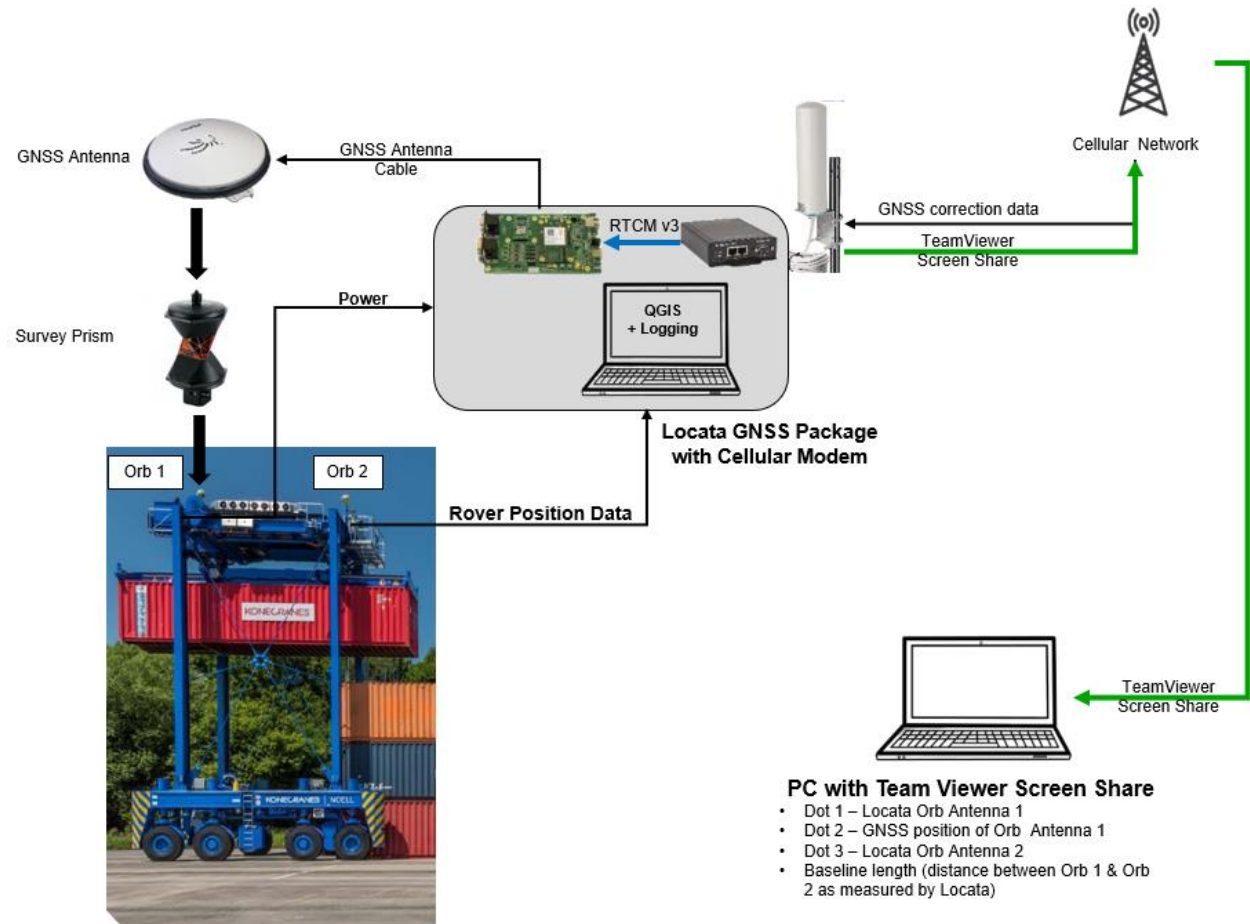

Figure 4-5: Positioning Test Equipment added onto Konecranes A-Strad Straddle Carrier

4.2.1.5 Locata Rover in Indoor Tests - T7

For the indoor tests (T7), the Locata Rover and its VRay Orb antenna were set up on a JRC supplied Test Trolley as shown in Figure 4-6. Pre-surveyed reference points on the ground indoors were established such that the Test Trolley could be moved to various reference points, repeatedly. The VRay Orb antenna was mounted on a pole that was fixed vertically to the Test Trolley. A pointer attached to the pole allowed the VRay Orb to be positioned directly over pre-surveyed points on the ground.

A survey prism was installed on top of the VRay Orb antenna and a Total Station (not shown in the figure) was used to track the prism as a positioning truth reference.

The Rover position was displayed on a laptop in real-time, at a rate of 10Hz.

The full test setup for Indoor Positioning Test T7 is show in Figure 4-7.



Figure 4-6: Locata Rover Setup with Locata VRay Orb Antenna for Indoor Positioning Test

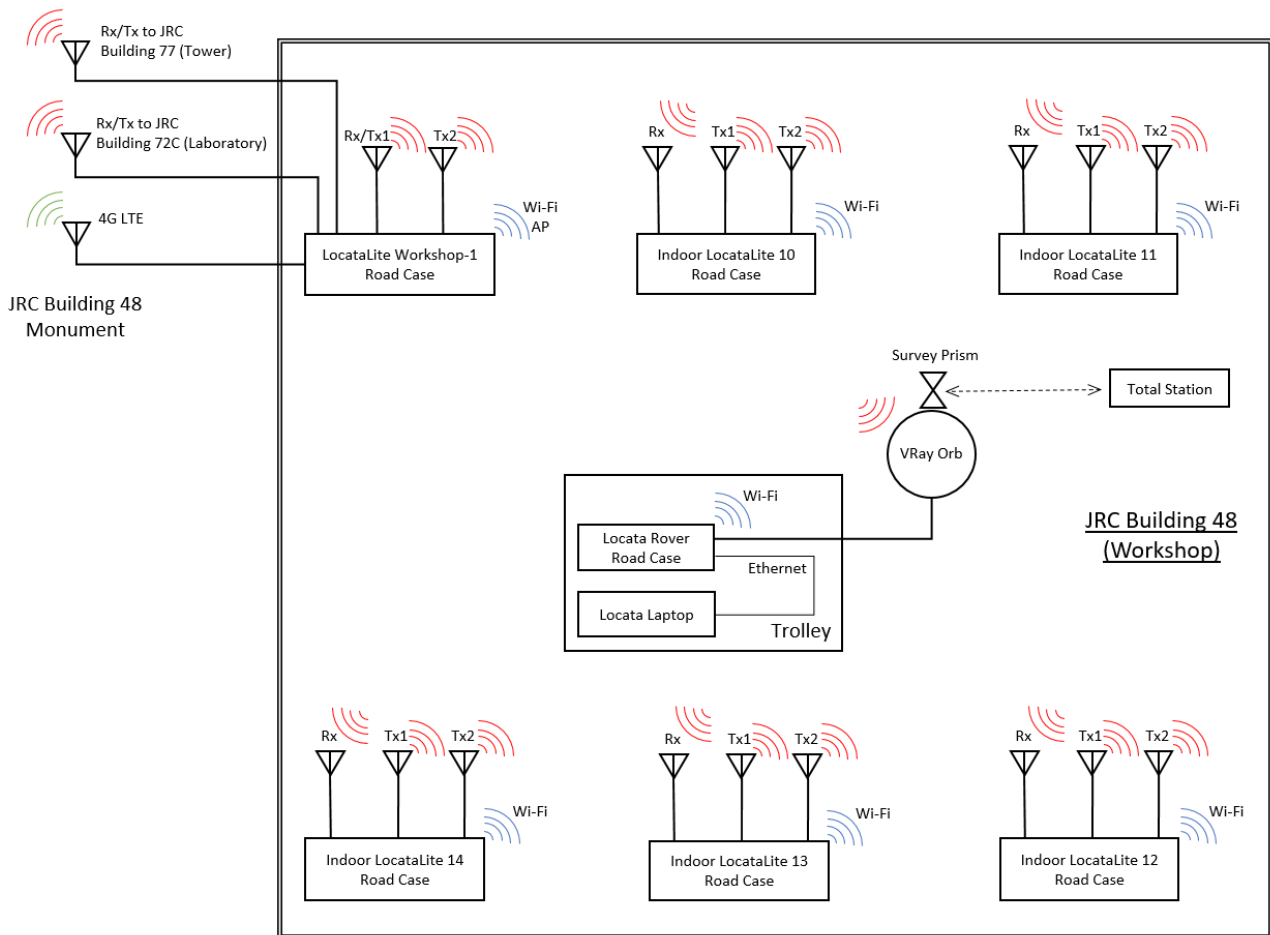

Figure 4-7: Setup for Indoor Positioning in Building 48 (Workshop)

4.2.2 Measurement Method

In all test cases, the Locata Rover was configured to output positions in NMEA formatted Latitude, Longitude, and Ellipsoid Height. For outdoor tests (T6), position data was time tagged with UTC and GNSS time. For indoor tests (T7), position data was time tagged with UTC time originating from Master LocataLite JRC-1.

A survey prism was mounted co-centrally with the Locata VRay Orb antenna for reference measurements in both T6 and T7. A GNSS antenna was mounted on top of the survey prism in test T6.

The following method was used to assess Locata accuracy:

1. Convert all position data to local topocentric East, North, Up (ENU) with respect to a pre-defined origin at the test site.
2. Time align Locata and the reference system data either using time tags (in case of GNSS reference data) or static data points (in case of the Total Station).
3. Calculate the topocentric East, North differences of Locata position data compared to the reference.
4. Generate the test matrix listed in Table 4-1.

All LocataLites were configured with coordinates in an Earth-Centred, Earth-Fixed (ECEF) XYZ frame.

For test T6, all LocataLites were surveyed in ETRF89 ECEF XYZ consistent with Germany's satellite positioning service (SAPOS).

For test T7, all LocataLites were surveyed in a local coordinate system and transformed into ETRF89 ECEF XYZ coordinates as described in the Section 4.3.2. Four points (RT1 – RT4), marked on the walls inside

Building 48 (Workshop) by using retroreflective markers, were surveyed in parallel to the LocataLite antenna survey. These points were later used as a reference to set up and orient a Total Station using the resection method.

Point ID	Locata local East (m)	Locata local North (m)	Locata local Height (m)
RT1	2.890	16.745	2.034
RT2	14.416	20.360	3.194
RT3	31.131	12.567	2.990
RT4	14.577	2.616	3.244

Table 4-2: Building 48 (Workshop) Reference Points for T7

GNSS and Total Station comparison data was consistent with the Locata Rover data in the following ways:

- The GNSS receiver used RTK corrections from the SAPOS network and was therefore consistent with NMEA data from the Locata Rover.
- The Total Station data was recorded in the local coordinate system and then transformed into ETRF89 ECEF XYZ coordinates.

4.3 Coordinate Transformations

4.3.1 Local Coordinates

JRC provided Locata with coordinates of three previously surveyed control points P1 to P3. This local frame was defined such that the origin was situated at the South-West corner of Building 48 (Workshop). P1 was defined as exactly 7 m East, 10 m North and 0 m Height. This system was rotated from True North with Local Coordinates East going through P1 and P2. Points P1 to P3 have physical marks on the floor of Building 48 (Workshop).

The LocataLite antenna survey was carried out in the local coordinate system with the Total Station setup on P3 and back-sighting outside point TS. These LocataLite antenna survey coordinates were converted to ECEF XYZ and used in the LocataLite configuration files.

Point ID	Locata local East (m)	Locata local North (m)	Locata local Height (m)
P1	7.000	10.000	0.000
P2	30.001	10.004	0.002
P3	13.982	10.002	-0.004
TS	-57.538	9.526	-1.099
BS	-50.597	81.881	-2.341

Table 4-3: Building 48 (Workshop) Control Points

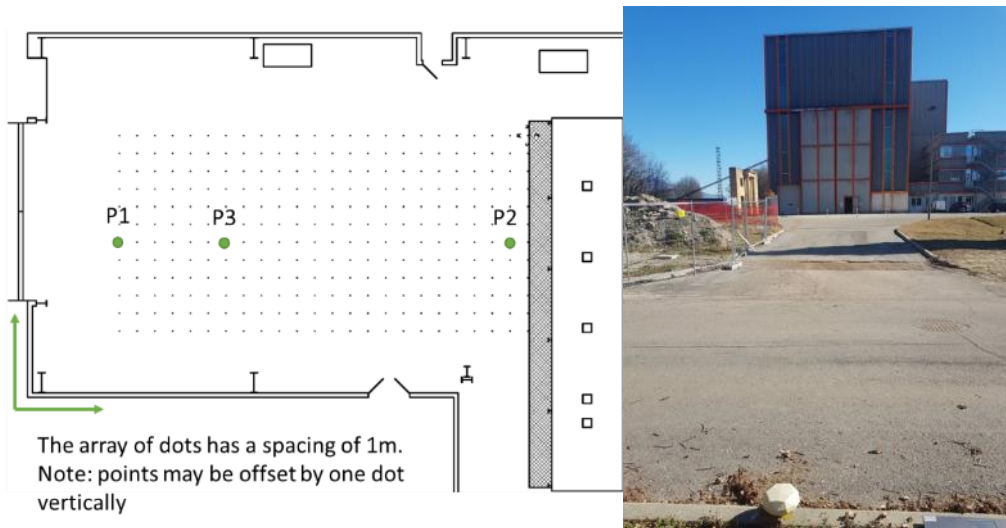

Figure 4-8: Indoor Test Survey Control Points

4.3.2 ECEF Coordinate Transformation

LocataLite antenna coordinates were defined in ECEF XYZ while the rover provided NMEA output in Latitude, Longitude and Height. The rover also supported ECEF XYZ, Topocentric ENU and Local ENU through its LBMP binary message protocol.

The transformation between Local coordinates and ETRF ECEF XYZ was computed in the following way:

- 1) Determine ETRF89 ECEF XYZ coordinates for P3
 - a) Input data: ETRF89 coordinates for TS (Total Station) and JRC survey coordinates.
 - b) Set TS as topocentric origin
 - c) Compute topocentric coordinates of P3 using JRC survey coordinates
 - d) Rotate P3 topocentric coordinates to ETRF89 ECEF:
$$P3_ECEF_XYZ = [4403048.4910, 668175.6670, 4550942.3538]$$
- 2) Compute transformation rotation between local and JRC survey coordinates
 - a) Input data: P1 to P3 local and JRC survey coordinates.
 - b) Set P3 as origin in JRC survey coordinates:
$$P3_local_ENU = [13.982000, 10.002000, 0.0]$$
 - c) Compute least squares Helmert 2D transformation to estimate rotation about Z/Up axis
$$Local_to_Topo_rotation = [-0.0956187329525533] \text{ radians}$$
- 3) Full transformation method from Local ENU to ETRF89 ECEF XYZ
 - a)
$$Topo_ENU = (local_ENU - P3_local_ENU) \cdot [Local_to_Topo_rotation \text{ matrix}]$$
 - b)
$$ETRF_ECEF_XYZ = (Topo_ENU) \cdot [Topo_to_ECEF_rotation \text{ matrix}] + P3_ECEF_XYZ$$

4.3.3 JRC Survey Coordinates

Point ID	Local East (m)	Local North (m)	Local Height (m)
Back-sight	500.000	572.668	98.758
Total Station	500.000	500.000	100.000
P1	564.198	506.635	101.099
P2	587.093	508.835	101.100
P3	571.148	507.304	101.095

Table 4-4: Building 48 (Workshop) Reference Point Local Coordinates

ETRF	Lat (deg)	Lon (deg)	Height (m)
Back-sight	45.8132160321	8.6280919249	257.651
Total Station	45.8125629761	8.6280523327	258.847

Table 4-5: Back-sight and Total Station Coordinates in Latitude, Longitude and Height



Figure 4-9: JRC Survey Coordinates

4.4 LocataNets, Reference Systems, and Test Tracks/Points

Locata used an existing customer's LocataNet for the outdoor positioning tests (T6). This network belongs to Konecranes in Düsseldorf, Germany. For indoor tests (T7), Locata setup an indoor LocataNet in the JRC Building 48 (Workshop).

4.4.1 Outdoor LocataNet – Konecranes, Düsseldorf, Germany

A 3-dimensional view of the Locata test area at the Konecranes Düsseldorf site is shown in Figure 4-10. This LocataNet includes seven LocataLites which are permanently installed to meet the needs of Konecranes' own R&D and test facility. LocataLite antennas are mounted approximately 22 m above ground level and the Locata VRay Orb antennas are mounted on top of the A-Strads that are approximately 16 m in height.

This LocataNet is synchronized to UTC Time via GNSS as required by the customer.



Figure 4-10: Outdoor Positioning Test – LocataNet 3D View

4.4.1.1 Reference Systems

A survey grade GNSS antenna and a survey prism were mounted co-centrally on top of the VRay Orb antenna as shown in Figure 4-5.

A Total Station was used as the primary reference system for static positions while the GNSS was used for kinematic positions. GNSS data was validated against the Total Station measurements in post-processing.

4.4.1.2 Test Tracks

Figure 4-11 shows a plan view of the Konecranes LocataNet with the A-Strad travel lane centrelines marked. A-Strads were programmed to travel along lane centrelines shown and performed 90° or 180° turns subjected to their minimum turn radius.

Test tracks included multiple static points such that Locata and GNSS data could be correlated with the Total Station data. The fully-autonomous A-Strads were programmed to repeat each test track at least twice.

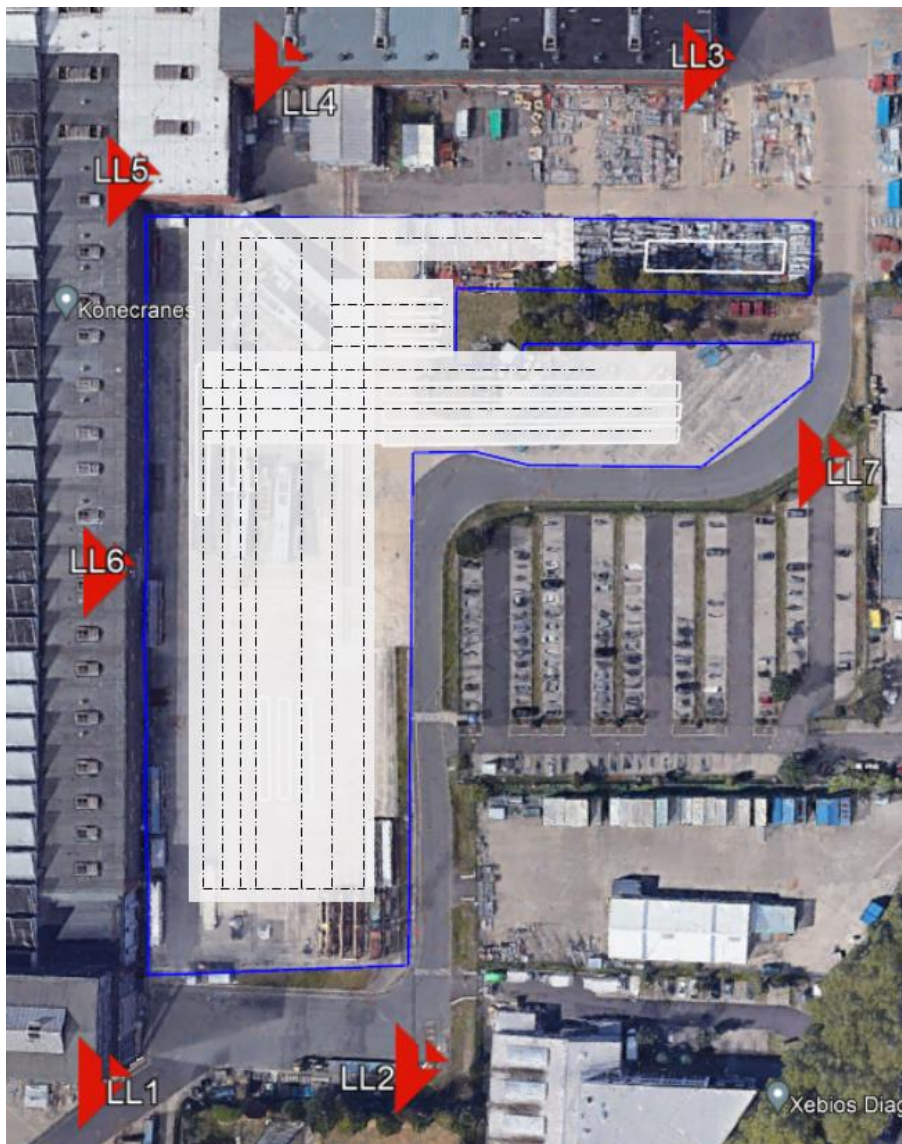

Figure 4-11: Outdoor Positioning Test – A-Strad Lane Centrelines

4.4.2 Indoor LocataNet – JRC Building 48 (Workshop)

A 1m x 1m grid of metal plates embedded in the floor of the JRC Workshop were used as visual markers for indoor testing. Twenty-three of these plates were used to create a 3m x 5m grid of test points, as shown in Figure 4-12.

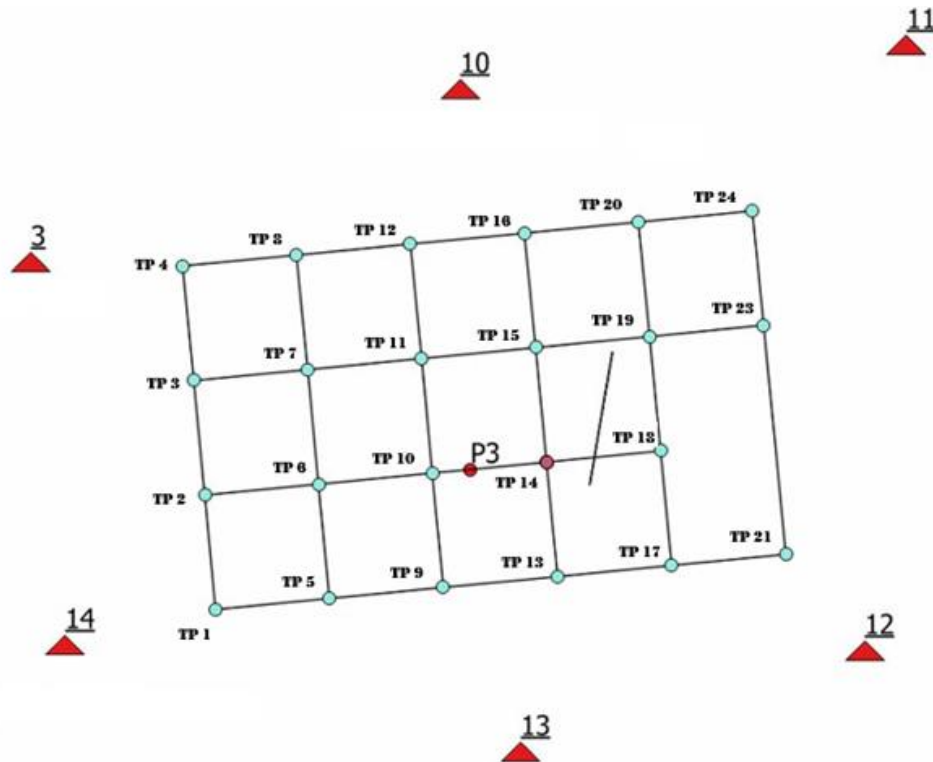

Figure 4-12: Locata Indoor Positioning Test – LocataLite Layout and Surveyed Test Points

4.4.2.1 Reference Systems

A Total Station was used as the reference system in the indoor positioning test (T7) facilitated by a survey prism mounted co-centrally with the VRay Orb antenna, as shown in Figure 4-6.

4.4.2.2 Test Tracks

Test tracks were defined by connecting a selected set of marked grid points and the Trolley was moved along each of these test tracks repeatedly.

A subset of the available grid points shown in Figure 4-12 were used in testing. Survey points 3, 6, 13, 14, 19, 20, and 23 were occupied twice in two different data collections (forward and reverse), remaining static for at least one minute each. The static point occupation allowed Total Station data to be correlated against Locata data.

4.5 Measurement Formats

Locata Rovers output LBMP data in addition to NMEA GPGSV, GPGGA, GPRMC, and GPGSA messages. The message specification is included in the Locata Rover User's Manual Appendix A.

GNSS data included NMEA GPGSV, GPGGA, GPRMC, and GPGSA messages.

Total Station data was provided in CSV format with topocentric ENU and Geodetic Latitude, Longitude, Height. Additionally, raw Total Station measurements were provided in a text file.

All test data was provided to the JRC engineers for full independent traceability of results. Refer to the D220 Test Technical Notes document for further details.

4.6 Test Cases

This section includes the setup instructions for all the positioning test cases.

4.6.1 System Verification – T1

Test ID	T1
Test Name	System verification
Objective	Setup DUT and verify that it is operating correctly
Output	DUT is ready
Time to execute	< 60 min
Metrics	Pass / Fail

Setup

1. Confirm LocataNet is operational.
2. Setup DUT and verify that Rover has a cm-level position solution.
3. Verify that reference system is operating correctly.
4. Verify that data is being recorded correctly.

4.6.2 Static Outdoor Positioning – T6A

Test ID	T6A
Test Name	Static outdoor positioning
Objective	To assess static positioning in an outdoor industrial environment
Output	PVT (NMEA & LBMP)
Time to execute	< 6 hrs
Metrics	Boxplot per point

Setup

1. Keep A-Strad static for 5 min and execute T1.
2. Move to predefined point 1.
3. Keep A-Strad static for at least 1 min.
4. Repeat steps (2) – (4) for all predefined points.

4.6.3 Kinematic Outdoor Positioning – Operational Environment – T6B

Test ID	T6B
Test Name	Kinematic outdoor positioning – Operational environment
Objective	To assess dynamic positioning accuracy in an outdoor industrial environment
Output	PVT (NMEA & LBMP)
Time to execute	< 6 hrs
Metrics	CDF of 2D difference against GNSS

Setup

1. Keep A-Strad static for 5 min and execute T1.
2. Conduct predefined track 1.
3. Finish with 5 min static.
4. Repeat steps (2) & (3) at least 2 times.
5. Repeat steps (2) – (4) for all predefined 5 tracks.

4.6.4 Static Indoor Positioning – T7A

Test ID	T7A
Test Name	Indoor positioning
Objective	To assess static positioning accuracy in an indoor industrial environment
Output	PVT (NMEA & LBMP)
Time to execute	< 6 hrs
Metrics	Boxplot per point

Setup

1. Keep Test Trolley static for 5 min and execute T1.
2. Move Test Trolley to point 1.
3. Leave static for at least 1 minute at point 1.
4. Repeat (2) and (3) for all remaining points.
5. Repeat (2) and (3) in reverse order until point 1 is reached.

4.6.5 Kinematic Indoor Positioning – T7B

Test ID	T7B
Test Name	Indoor positioning
Objective	To assess dynamic positioning accuracy in an indoor industrial environment
Output	PVT (NMEA & LBMP)
Time to execute	< 6 hrs
Metrics	CDF of cross-track error against Total Station

Setup

1. Keep Test Trolley static for 5 min and execute T1.
2. Conduct predefined track 1.
3. Finish with 5 min static.
4. Repeat steps (2) & (3) at least 2 times.
5. Repeat steps (2) – (4) for all predefined tracks.

4.7 Equipment List – Positioning Tests

Shown in Table 4-6 is the equipment list for the positioning tests.

Test	Parts List	Number of Units	Supplier	Notes
Outdoor Positioning	LocataLites	7	Locata	Existing operational site with LocataLites setup
	LocataLite Antennas and cables	21	Locata	Existing operational site with LocataLites setup
	Locata rover & VRay Orb antenna	2	Locata	Setup on customer straddle carriers (A-Strads)
	Reference GNSS receiver & antenna	1	Locata	GNSS antenna mounted on top of VRay Orb antenna
	Survey prism	1	Locata	Prism mounted on top of the VRay Orb antenna
	Total Station	1	Locata	
	4G / LTE Modem + antenna	2	Locata	One at each laptop (for remote monitoring only)
	Laptop on straddle for display & logging	1	Locata	Located on the straddle running QGIS to show Locata & GNSS positions in real-time.
	Laptop on ground for remote access to straddle laptop	1	Locata	Using TeamViewer to remotely observe the straddle laptop
	Indoor Positioning	LocataLites	6	Locata
LocataLite positioning antenna sets (each set had 3 antennas)		6	Locata	2 Wall & 4 Corner antenna sets at 2.5 to 3.0 m height
LocataLite timing antenna set (2 antennas per set)		1	Locata	Cube antennas to tie into timing backbone
Locata Rover, VRay Orb antenna, uninterrupted power supply, and Trolley attachment		1	Locata	Include power and other cables
Laptop for display & logging		1	Locata	Laptop displays Locata positions in real-time
Survey prism		1	Locata	Prism mounted on top of the VRay Orb antenna
Test Trolley		1	JRC	
Total Station		1	JRC	No GEOCOM option

Table 4-6: Equipment List for Positioning Tests

5 Locata Resilience & Monitoring Tests

LocataLites and Locata Rovers are designed and sold to partners operating in harsh industrial environments. These industrial and safety-of-life applications require high service availability and reliability. These environments, however, also limit frequent physical access to the deployed system hardware. Locata devices are therefore designed with these constraints in mind and have built-in resilience and monitoring capabilities.

5.1 Test Overview

The indoor LocataLites in JRC Building 48 (Workshop) were used to demonstrate the monitoring and resilience capabilities listed in Table 5-1. The setup used is equivalent to the one shown in Figure 4-7.

Test ID/ Name, Location	Output	Date, Duration & Method	Metrics
T1 System verification	DUT is ready	Day 1 of all tests < 30 min (test time) - setup validation only	Pass / Fail
Resilience & network monitoring (same as T4) T8A – Remote monitoring T8B – Bracing T8C – Dual Master	HTML pages showing device status and the failover response	March 24, 2022 - JRC Ispra < 30 min each	Pass / Fail

Table 5-1: Resilience & Monitoring Test Case Summary

5.2 Test Method

5.2.1 Remote Monitoring

All LocataLites used in timing and positioning tests were set up with remote access capability, as described in Section 3.1.4 Remote Access and 3.3 OTA Outdoor Test Sites.

The Locata Laptop on the Test Trolley was connected to the same local area network as the indoor LocataLites and was used to show the following remote monitoring features:

1. Direct webpage access – ability to login to the built-in web server in each LocataLite to monitor detailed information about its current operations and critical historical data.
2. Real-time information via Locata *Signal Tracking & Visibility* webpage – ability to login to one LocataLite and be able to monitor critical information from other LocataLites that were directly tracked in real-time.
3. LocataNet-Wide Information via *LocataNet Health & Status* webpage - ability to login to one LocataLite and monitor information from all LocataLites in the LocataNet.

5.2.2 System Resilience Features

The resilience features demonstrated were TimeLoc Bracing and Dual Master, which provide redundancy in the event of TimeLoc Reference outages.

TimeLoc Bracing assigns multiple reference LocataLites to provide TimeLoc redundancy in the event of a loss of a reference LocataLite. If this occurs, TimeLoc will continue uninterrupted using other available reference LocataLites.

Dual Master operates at the LocataNet level in which a Secondary (Alternate) Master is configured to act as the TimeLoc Reference for the LocataNet in the event of a loss of the Primary Master LocataLite.

The following configuration changes were made to the indoor LocataLites to illustrate both the TimeLoc Bracing and Dual Master features:

- LocataLite 10 and LocataLite 14 were configured as Primary and Secondary Master LocataLites respectively.
- LocataLite 11, 12, and 13 were configured to use the TimeLoc Bracing feature. As a result, LocataLites 11, 12, and 13 were able to use both LocataLite 10 and LocataLite 14 as their TimeLoc references.

The test configuration is shown in Figure 5-1. LocataLite 3 (Workshop-1) was not used for these tests.

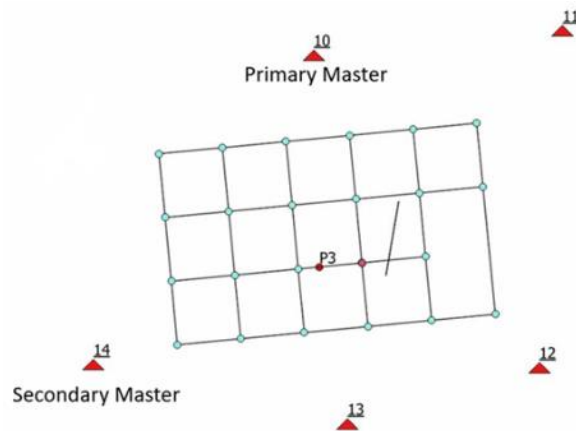

Figure 5-1: LocataNet Used for Resilience Demonstration

The test demonstration was performed as follows:

1. LocataLites 11, 12, and 13 were remotely monitored to confirm they were using signals from LocataLite 10 and LocataLite 14 as TimeLoc Reference signals.
2. The Rover was converged to a centimetre level solution.
3. The Primary Master, LocataLite 10, was powered down while the status of the other LocataLites were remotely monitored.
4. All other LocataLites ceased tracking signals from LocataLite 10, leaving only the signals from LocataLite 14 as their TimeLoc Reference signals. LocataLites 11, 12, and 13 seamlessly handled the loss of LocataLite 10. LocataLite 14 changed its role from a Slave running as Alternate Master to Active Master. This occurred automatically, independently and seamlessly, with no intervention or disruption to the LocataNet.
5. When LocataLite 10 was returned to service it detected the presence of the operating LocataNet and re-joined the network as a Slave to the Alternate Master (LocataLite 14) using the usual TimeLoc process.
6. Over the next 30 minutes LocataLite 10 negotiated to take back control of the LocataNet from LocataLite 14. This process was seamless, independent and automatic with the result being LocataLite 10 again

becoming the Active Master while LocataLite 14 reverted to Alternate Master operating as a Slave. This negotiation was handled via the navigation (NAV) data encoded on the broadcast Locata signals.

5.3 Test Cases

This section includes the setup instructions used for all the test cases.

5.3.1 System Verification – T1

Test ID	T1
Test Name	System verification
Objective	Setup DUT and verify that it is operating correctly
Output	DUT is ready
Time to execute	< 30 min
Metrics	Pass / Fail

Setup

1. Confirm LocataNet is operational.
2. Verify that the test laptop can access the LocataLites.

5.3.2 Remote Monitoring – T8A

Test ID	T8A
Test Name	Remote monitoring
Objective	To assess the remote monitoring features in LocataLites and LocataNets
Output	HTML pages showing device status
Time to execute	< 30 min
Metrics	Pass / Fail

Setup

1. Execute T1.
2. Access *LocataLite Status* web page (main page).
3. Access *LocataLite Signal Tracking & Visibility* webpage.
4. Access *LocataLite LocataNet Health & Status* webpage.

5.3.3 Bracing – T8B

Test ID	T8B
Test Name	Bracing
Objective	To assess the ability of LocataLites to seamlessly handle the loss of a Reference LocataLite
Output	HTML pages showing the failover response
Time to execute	< 30 min
Metrics	Pass / Fail

Setup

1. Execute T1.
2. Choose a test LocataLite (other than 10) and access its *TimeLoc Bracing Status* webpage.
3. Observe the *Usable Signal Count* in the *LocataLite Info* section.
4. Take LocataLite 10 offline.
5. Observe the *Usable Signal Count* in the *LocataLite Info* section.
6. Observe *TimeLoc Uptime* in the *LocataLite Status* webpage for continuity.

5.3.4 Dual Master – T8C

Test ID	T8C
Test Name	Dual Master
Objective	To assess the ability of LocataNet to seamlessly handle the loss of the Master LocataLite
Output	HTML pages showing the failover response
Time to execute	< 30 min
Metrics	Pass / Fail

Setup

1. Execute T1.
2. Choose a test LocataLite (other than 10 and 14) and access its *TimeLoc Status* webpage.
3. Observe the *TimeLoc Ref Signal* field.
4. Take LocataLite 10 offline.
5. Observe the *TimeLoc Ref Signal* field.
6. Observe *TimeLoc Uptime* in the *LocataLite Status* webpage for continuity.

6 Test Results

6.1 Timing Performance

6.1.1 Timing Performance Summary

The cumulative duration over all timing tests was 6 days (144 hours).

The average Locata internal time transfer performance over all timing tests was 261 picoseconds with a standard deviation of 49 picoseconds.

The average Locata external time transfer performance over all timing tests was 218 picoseconds with a standard deviation of 565 picoseconds.

The average Locata to UTC performance over all timing tests was 141 nanoseconds with a standard deviation of 46 nanoseconds.

The average Locata time transfer to a mobile Rover was 1.2 nanoseconds with a standard deviation of 0.7 nanoseconds.

Locata UTC time transfer was heavily influenced by the performance of the Rubidium time standard used. Locata time transfer performance was always at the sub-nanosecond level, whereas the Rubidium based Locata UTC Time Standard was observed during some tests to drift 100's of nanoseconds. The End-Node LocataLite JRC-2 followed this drift, even as the Master LocataLite JRC-1 and the End-Node LocataLite JRC-2 remained tightly synchronized to the Locata UTC Time Standard.

These results demonstrate that a LocataNet can maintain extremely fine time synchronisation with any external reference clock source. The selection of external reference clock source can be driven by performance requirement, for example a Caesium atomic clock may be used for improved time stability.

The table below shows Locata average time transfer performance across all timing tests.

Locata Time Transfer Type	Samples [1 Hz]	Mean [ns]	Peak-to-Peak [ns]	MTIE [ns]	Std Dev [ns]	3 Sigma [ns]
Average Internal Time Transfer (over 6 days)	518406	0.261	0.434	0.494	0.049	0.147
Average External Time Sync (over 6 days)	518406	-0.043	5.647	3.009	0.567	1.699
Average External Time Transfer (over 6 days)	518406	0.218	5.641	3.062	0.565	1.695
Average Locata to UTC Comparison (over 6 days) *	518406	141.180	209.833	312.900	46.093	138.279
Average Clock Comparison (over 6 days) *	518406	140.962	209.264	312.522	46.092	138.275
Time Transfer to Mobile Rover	14401	1.238	3.3	2.9	0.745	2.235

* Note that these statistics are impacted by the drift between the Locata UTC Standard and JRC Reference observed in several of the tests.

Table 6-1: Locata Timing Performance Summary

6.1.1.1 Locata Alternative PNT Timing Performance Levels

The table below shows Locata alternative PNT timing performance levels. The 1 day values for accuracy, synchronization, and stability are averages obtained from all 24 hour time transfer tests (T2A – T2F). Values shown for 14 days and 100 days are “projected” from Locata experience because a test duration of that length was not conducted at the JRC.

Timing Accuracy to UTC comprises Locata External Time Transfer performance plus the accuracy of the chosen External Time Standard. Similarly, Timing Stability comprises Locata External Time Transfer performance plus the stability of the chosen External Time Standard.

Locata Timing Performance Parameters	Number of Days after GNSS Outage		
	1 day Demonstrated @ JRC	14 days (Projected)	100 days (Projected)
Availability (%)	100	99.9999	99.9999
Continuity (per hour)	1	$1 - 1 \times 10^{-8}$	$1 - 1 \times 10^{-8}$
Integrity (per hour)	1	$1 - 1 \times 10^{-7}$	$1 - 1 \times 10^{-7}$
Time To Alert (second)	1 second		
Timing Accuracy to UTC (3 sigma)	1.7 ns + Accuracy of chosen External Time Standard		
Timing Accuracy Internal (3 sigma)	150 ps		
Time Synchronization (Allan Deviation)			
- Internal Synchronization	3×10^{-15}	same	same
- External Synchronization	4×10^{-14}		
Timing Stability (Allan Deviation)	4×10^{-14} + Stability of chosen External Time Standard		
First time to provide services upon cold start	5 minutes per TimeLoc Hop		

Table 6-2: Locata Alternative PNT Timing Performance Levels

6.1.1.2 Locata Internal Time Transfer

Master LocataLite (JRC-1) to End-Node LocataLite (JRC-2) Locata Internal Time Transfer						
Test	Samples [1 Hz]	Mean [ns]	Peak-to-Peak [ns]	MTIE [ns]	Std Dev [ns]	3 Sigma [ns]
T2A Coax Cable	86401	-0.073	0.415	0.33	0.048	0.144
T2B OTA Indoor	86401	0.168	0.293	0.304	0.034	0.103
T2C OTA Outdoor Local Area	86401	0.126	0.43	0.339	0.05	0.151
T2D Fibre Optic 1km	86401	0.207	0.396	0.353	0.042	0.126
T2E OTA Outdoor Wide Area	86401	0.584	0.752	0.944	0.085	0.254
T2F OTA Outdoor to Indoor	86401	0.552	0.317	0.695	0.035	0.104

Table 6-3: Locata Internal Time Transfer Statistics

Master LocataLite (JRC-1) to End-Node LocataLite (JRC-2) Locata Internal Time Transfer						
Test	Allan Dev 20000 tau	Allan Var 20000 tau	Overlapping Allan Dev 40000 tau	Overlapping Allan Var 40000 tau	Modified Allan Dev 20000 tau	Modified Allan Var 20000 tau
T2A Coax Cable	9.24E-16	8.54E-31	1.58E-15	2.50E-30	1.84E-15	3.40E-30
T2B OTA Indoor	3.79E-15	1.43E-29	1.51E-15	2.26E-30	2.01E-16	4.02E-32
T2C OTA Outdoor Local Area	5.20E-15	2.71E-29	2.13E-15	4.55E-30	3.11E-16	9.68E-32
T2D Fibre Optic 1km	4.11E-15	1.69E-29	1.43E-15	2.04E-30	1.05E-15	1.09E-30
T2E OTA Outdoor Wide Area	4.04E-15	1.64E-29	3.72E-15	1.38E-29	4.80E-16	2.30E-31
T2F OTA Outdoor to Indoor	2.04E-15	4.16E-30	1.51E-15	2.28E-30	5.99E-16	3.59E-31

Table 6-4: Locata Internal Time Transfer Allan Deviations

For the Allan Deviation and Variance values 1 tau = 1 second, 20000 tau = 5.6 hrs and 40000 tau = 11.1 hrs.

6.1.1.3 Locata External Time Synchronization

Locata UTC Time Standard (S650) to Master LocataLite (JRC-1) Locata External Time Synchronization						
Test	Samples [1 Hz]	Mean [ns]	Peak-to-Peak [ns]	MTIE [ns]	Std Dev [ns]	3 Sigma [ns]
T2A Coax Cable	86401	-0.069	6.099	3.137	0.543	1.628
T2B OTA Indoor	86401	0.006	5.142	2.688	0.569	1.707
T2C OTA Outdoor Local Area	86401	0	6.196	3.274	0.616	1.849
T2D Fibre Optic 1km	86401	-0.093	4.893	2.547	0.549	1.646
T2E OTA Outdoor Wide Area	86401	-0.18	6.099	3.577	0.551	1.654
T2F OTA Outdoor to Indoor	86401	0.081	5.454	2.829	0.571	1.712

Table 6-5: Locata External Time Synchronization Statistics

Locata UTC Time Standard (S650) to Master LocataLite (JRC-1) Locata External Time Synchronization						
Test	Allan Dev 20000 tau	Allan Var 20000 tau	Overlapping Allan Dev 40000 tau	Overlapping Allan Var 40000 tau	Modified Allan Dev 20000 tau	Modified Allan Var 20000 tau
T2A Coax Cable	4.69E-14	2.20E-27	2.51E-14	6.31E-28	1.92E-15	3.70E-30
T2B OTA Indoor	6.71E-14	4.50E-27	2.47E-14	6.09E-28	2.98E-15	8.87E-30
T2C OTA Outdoor Local Area	6.00E-14	3.60E-27	2.78E-14	7.73E-28	2.52E-15	6.34E-30
T2D Fibre Optic 1km	1.44E-14	2.07E-28	2.33E-14	5.42E-28	1.67E-15	2.78E-30
T2E OTA Outdoor Wide Area	3.21E-14	1.03E-27	2.38E-14	5.65E-28	2.00E-15	4.00E-30
T2F OTA Outdoor to Indoor	3.29E-14	1.08E-27	2.52E-14	6.36E-28	1.99E-15	3.96E-30

Table 6-6: Locata External Time Synchronization Allan Deviations

For the Allan Deviation and Variance values 1 tau = 1 second, 20000 tau = 5.6 hrs and 40000 tau = 11.1 hrs.

6.1.1.4 Locata External Time Transfer

Locata UTC Time Standard (S650) to End-Node LocataLite (JRC-2) Locata External Time Transfer						
Test	Samples [1 Hz]	Mean [ns]	Peak-to-Peak [ns]	MTIE [ns]	Std Dev [ns]	3 Sigma [ns]
T2A Coax Cable	86401	-0.142	6.06	3.085	0.544	1.632
T2B OTA Indoor	86401	0.174	5.156	2.841	0.568	1.705
T2C OTA Outdoor Local Area	86401	0.125	6.177	3.407	0.613	1.838
T2D Fibre Optic 1km	86401	0.114	4.868	2.548	0.55	1.649
T2E OTA Outdoor Wide Area	86401	0.404	6.094	3.085	0.545	1.634
T2F OTA Outdoor to Indoor	86401	0.634	5.493	3.407	0.57	1.711

Table 6-7: Locata External Time Transfer Statistics

Locata UTC Time Standard (S650) to End-Node LocataLite (JRC-2) Locata External Time Transfer						
Test	Allan Dev 20000 tau	Allan Var 20000 tau	Overlapping Allan Dev 40000 tau	Overlapping Allan Var 40000 tau	Modified Allan Dev 20000 tau	Modified Allan Var 20000 tau
T2A Coax Cable	4.62E-14	2.13E-27	2.50E-14	6.27E-28	9.16E-16	8.38E-31
T2B OTA Indoor	6.34E-14	4.01E-27	2.46E-14	6.06E-28	2.84E-15	8.06E-30
T2C OTA Outdoor Local Area	6.43E-14	4.14E-27	2.76E-14	7.64E-28	2.36E-15	5.57E-30
T2D Fibre Optic 1km	1.06E-14	1.13E-28	2.33E-14	5.41E-28	1.45E-15	2.10E-30
T2E OTA Outdoor Wide Area	2.99E-14	8.95E-28	2.35E-14	5.50E-28	1.81E-15	3.26E-30
T2F OTA Outdoor to Indoor	3.39E-14	1.15E-27	2.52E-14	6.36E-28	2.09E-15	4.38E-30

Table 6-8: Locata External Time Transfer Allan Deviations

For the Allan Deviation and Variance values 1 tau = 1 second, 20000 tau = 5.6 hrs and 40000 tau = 11.1 hrs.

6.1.1.5 Locata to UTC Comparison

The following are measurements of the difference between JRC UTC Reference (FS740) and End-Node LocataLite (JRC-2), referred to as Locata to UTC Comparison.

JRC UTC Reference (FS740) to End-Node LocataLite (JRC-2) Locata to UTC Comparison						
Test	Samples [1 Hz]	Mean [ns]	Peak-to-Peak [ns]	MTIE [ns]	Std Dev [ns]	3 Sigma [ns]
T2A Coax Cable	86401	345.505	299.331	486.717	70.147	210.442
T2B OTA Indoor	86401	157.314	282.915	299.534	75.436	226.307
T2C OTA Outdoor Local Area	86401	-92.494	178.003	187.36	39.332	117.995
T2D Fibre Optic 1km	86401	125.148	275.576	251.097	61.013	183.04
T2E OTA Outdoor Wide Area	86401	-112.182	127.358	184.567	15.992	47.975
T2F OTA Outdoor to Indoor	86401	423.791	95.815	468.123	14.638	43.913

Table 6-9: Locata to UTC Comparison Statistics

JRC UTC Reference (FS740) to End-Node LocataLite (JRC-2) Locata to UTC Comparison						
Test	Allan Dev 20000 tau	Allan Var 20000 tau	Overlapping Allan Dev 40000 tau	Overlapping Allan Var 40000 tau	Modified Allan Dev 20000 tau	Modified Allan Var 20000 tau
T2A Coax Cable	1.18E-12	1.40E-24	6.27E-13	3.93E-25	5.54E-13	3.07E-25
T2B OTA Indoor	3.92E-13	1.54E-25	6.98E-13	4.87E-25	9.46E-13	8.95E-25
T2C OTA Outdoor Local Area	7.18E-13	5.15E-25	6.79E-13	4.61E-25	5.43E-13	2.95E-25
T2D Fibre Optic 1km	2.61E-13	6.79E-26	8.15E-13	6.65E-25	3.67E-13	1.35E-25
T2E OTA Outdoor Wide Area	1.67E-12	2.78E-24	5.05E-13	2.55E-25	2.89E-13	8.36E-26
T2F OTA Outdoor to Indoor	1.58E-12	2.50E-24	8.50E-13	7.22E-25	5.97E-13	3.57E-25

Table 6-10: Locata to UTC Comparison Allan Deviations

For the Allan Deviation and Variance values 1 tau = 1 second, 20000 tau = 5.6 hrs and 40000 tau = 11.1 hrs.

6.1.1.6 Clock Comparison

The following are measurements of the difference between JRC UTC Reference (FS740) and Locata UTC Time Standard (S650), referred to as Clock Comparison.

Note that the Locata UTC Time Standard was not resynchronized to GNSS prior to each test, as detailed in Section 3.4.1.3 Measurement Method and Table 3-5.

JRC UTC Reference (FS740) to Locata UTC Time Standard (S650) Clock Comparison						
Test	Samples [1 Hz]	Mean [ns]	Peak-to-Peak [ns]	MTIE [ns]	Std Dev [ns]	3 Sigma [ns]
T2A Coax Cable	86401	345.647	298.921	487.05	70.178	210.535
T2B OTA Indoor	86401	157.14	283.228	299.315	75.408	226.224
T2C OTA Outdoor Local Area	86401	-92.62	177.612	187.316	39.361	118.084
T2D Fibre Optic 1km	86401	125.034	274.121	249.921	61.016	183.047
T2E OTA Outdoor Wide Area	86401	-112.587	126.177	184.313	15.972	47.917
T2F OTA Outdoor to Indoor	86401	423.157	95.527	467.216	14.615	43.844

Table 6-11: Clock Comparison Statistics

JRC UTC Reference (FS740) to Locata UTC Time Standard (S650) Clock Comparison						
Test	Allan Dev 20000 tau	Allan Var 20000 tau	Overlapping Allan Dev 40000 tau	Overlapping Allan Var 40000 tau	Modified Allan Dev 20000 tau	Modified Allan Var 20000 tau
T2A Coax Cable	1.19E-12	1.42E-24	6.27E-13	3.93E-25	5.54E-13	3.07E-25
T2B OTA Indoor	4.04E-13	1.63E-25	7.01E-13	4.91E-25	9.48E-13	8.99E-25
T2C OTA Outdoor Local Area	6.76E-13	4.57E-25	6.80E-13	4.62E-25	5.44E-13	2.96E-25
T2D Fibre Optic 1km	2.50E-13	6.25E-26	8.14E-13	6.62E-25	3.67E-13	1.35E-25
T2E OTA Outdoor Wide Area	1.69E-12	2.85E-24	5.03E-13	2.53E-25	2.89E-13	8.33E-26
T2F OTA Outdoor to Indoor	1.57E-12	2.46E-24	8.50E-13	7.23E-25	5.98E-13	3.58E-25

Table 6-12: Clock Comparison Allan Deviations

For the Allan Deviation and Variance values 1 tau = 1 second, 20000 tau = 5.6 hrs and 40000 tau = 11.1 hrs.

6.1.1.7 Time Transfer to Mobile Rover

Source LocataLite (Workshop-1) to Locata Positioning Device (Rover)						
Test	Samples [1 Hz]	Mean [ns]	Peak-to-Peak [ns]	MTIE [ns]	Std Dev [ns]	3 Sigma [ns]
T2G Time Transfer to Mobile Rover	14401	1.238	3.3	2.9	0.745	2.235

Table 6-13: Time Transfer to Mobile Rover Statistics

Source LocataLite (Workshop-1) to Locata Positioning Device (Rover)						
Test	Allan Dev 4000 tau	Allan Var 4000 tau	Overlapping Allan Dev 4000 tau	Overlapping Allan Var 4000 tau	Modified Allan Dev 4000 tau	Modified Allan Var 4000 tau
T2G Time Transfer to Mobile Rover	2.80E-13	7.81E-26	3.18E-13	1.01E-25	1.03E-14	1.05E-28

Table 6-14: Time Transfer to Mobile Rover Allan Deviations

For the Allan Deviation and Variance values 1 tau = 1 second and 4000 tau = 1.1 hrs.

6.1.1.8 TimeLoc Measured Link Adjustments Summary

Plots of TimeLoc measured link adjustments are provided for every hop in each of the test configurations.

For T2C OTA Outdoor Local Area and T2E OTA Outdoor Wide Area, there are additional plots of measured link adjustments for each hop grouped by common geographic location, and a derived total link adjustment plot over all hops.

The measured link adjustments between LocataLite pairs over common sites have similar profiles. This is expected because environmental changes are common to both. There are also offsets between each pair as multipath can affect each pair independently.

The measured link adjustments for the following tests are noteworthy:

T2A – Copper/Coax Cable

The measured link adjustments shows 6.7 ps (2 mm) of variation up to an event at 14:00 UTC. A sudden negative offset of 60 ps (18 mm) was observed followed by a positive offset of 57 ps (17 mm) several minutes later. This event is consistent with a half-cycle carrier slip followed by an automatic TimeLoc link adjustment to correct the error. The magnitude of the event is also too small to register in the plot of Locata Internal Time Transfer.

T2B – OTA Indoor

The measured link adjustments shows less than 6.7 ps (2 mm) of variation over the entire 24 hours.

T2C - OTA Outdoor Local Area

The plot of total measured link adjustments over all 4 hops shows 0.218 ns (6.5 cm) of variation over 24 hours. In contrast, the internal time transfer TIC measurement shows a steady 0.126 ns (3.8cm) mean offset with 0.050 ns (1.5 cm) standard deviation.

T2D – Fibre Optic

The measured link adjustments show 0.747 ns (22 cm) of variation over 24 hours. Of note is a large adjustment at 08:30 UTC which correlated with the 1km roll of fibre being in direct sunlight through the office window. In contrast, Locata Internal Time Transfer is unchanging through this period.

T2E - OTA Outdoor Wide Area

The plot of total measured link adjustments over all 8 hops shows more than 2.5 ns (77 cm) of variation over the 24 hour test period. In contrast, the internal time transfer TIC measurement shows a steady 0.584 ns (17cm) mean offset with 0.085 ns (2.5 cm) standard deviation.

T2F – OTA Outdoor to Indoor

The measured link adjustments show a variation of 129 ps (39 mm) over the 24 hour test period. The observed adjustments are a combination of tropospheric effects over-the-air and the thermal variations on the total length of 57 m of coax cable connecting the antennas to the LocataLites.

6.1.1.9 Device Web Page Screenshots

The following is an example web page screenshot from End-Node LocataLite (JRC-2) at the end of test T2E OTA Outdoor Wide Area.

Note the TimeLoc Lineage field showing the 8 hops to Master LocataLite (JRC-1), which is then synchronized to the Locata UTC Time Standard.

All web page screenshots are made available upon request by the JRC.

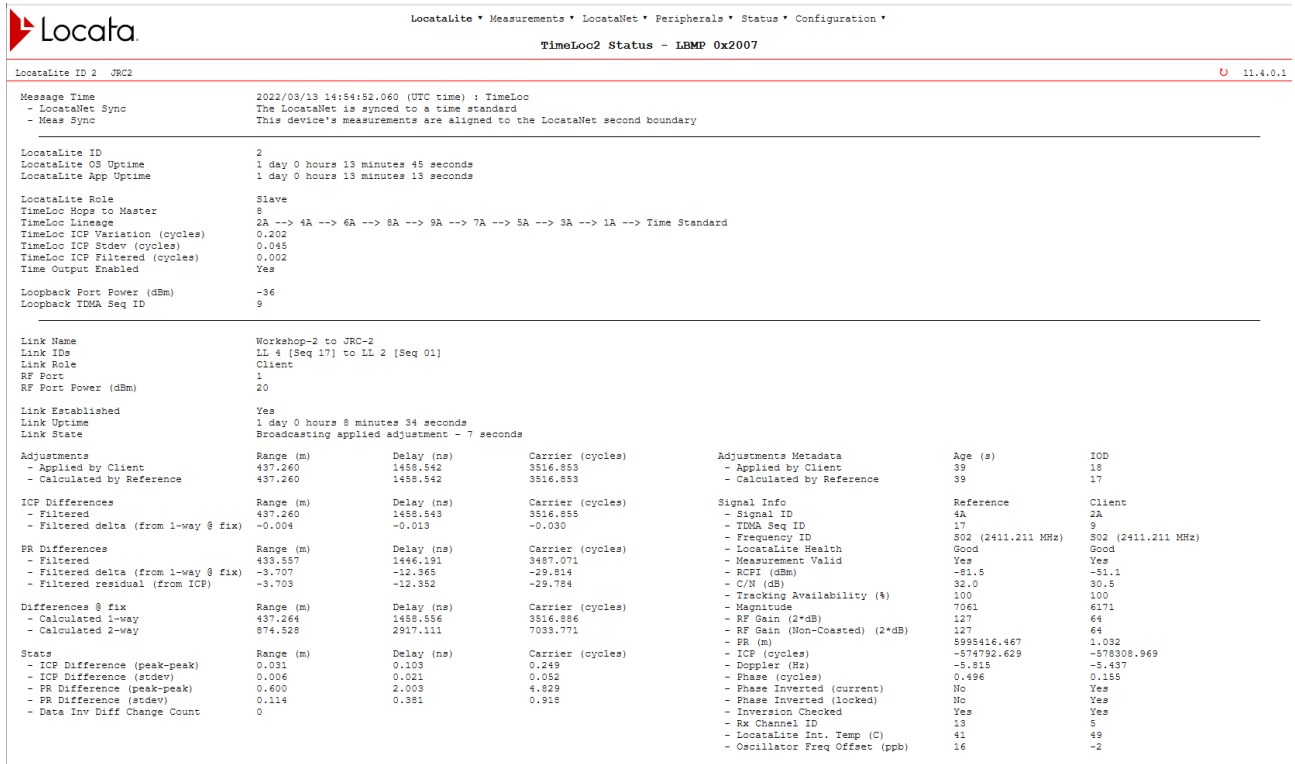

LocataLite ID 2 JRC2

LocataLite Measurements * LocataNet * Peripherals * Status * Configuration *
TimeLoc2 Status - LBMP 0x2007

11.4.0.1

Message Time 2022/03/13 14:54:52.060 (UTC time) : TimeLoc
LocataNet Sync The LocataNet is synced to a time standard
- Meas Sync This device's measurements are aligned to the LocataNet second boundary

LocataLite ID 2
LocataLite OS Uptime 1 day 0 hours 13 minutes 45 seconds
LocataLite App Uptime 1 day 0 hours 13 minutes 13 seconds

LocataLite Role Slave
TimeLoc Hops to Master 8
TimeLoc Lineage 2A --> 4A --> 6A --> 8A --> 9A --> 7A --> 5A --> 3A --> 1A --> Time Standard
TimeLoc ICP Variation (cycles) 0.202
TimeLoc ICP Stdev (cycles) 0.045
TimeLoc ICP Filtered (cycles) 0.002
Time Output Enabled Yes

Loopback Port Power (dBm) -36
Loopback TDMA Seq ID 9

Link Name Workshop-2 to JRC-2
Link ID LL 4 [Seq 17] to LL 2 [Seq 01]
Link Role Client
RF Port 1
RF Port Power (dBm) 20

Link Established Yes
Link Uptime 1 day 0 hours 8 minutes 34 seconds
Link State Broadcasting applied adjustment - 7 seconds

Adjustments	Range (m)	Delay (ns)	Carrier (cycles)	Adjustments Metadata	Age (s)	ID
- Applied by Client	437.260	1458.542	3516.853	- Applied by Client	39	18
- Calculated by Reference	437.260	1458.542	3516.853	- Calculated by Reference	39	17

ICP Differences	Range (m)	Delay (ns)	Carrier (cycles)	Signal Info	Reference	Client
- Filtered	437.260	1458.543	3516.855	- Signal ID	4A	2A
- Filtered delta (from 1-way @ fix)	-0.004	-0.013	-0.030	- TDMA Seq ID	17	9
				- Frequency ID	S02 (2411.211 MHz)	S02 (2411.211 MHz)

FR Differences	Range (m)	Delay (ns)	Carrier (cycles)	LocataLite Health <th>Good</th> <th>Good</th>	Good	Good
- Filtered	439.557	1446.191	3487.071	- LocataLite Health	Good	Good
- Filtered delta (from 1-way @ fix)	-3.707	-12.365	-29.814	- Measurement Valid	Yes	Yes
- Filtered residual (from ICP)	-3.703	-12.352	-29.784	- RCFI (dBm)	-81.5	-81.1
				- C/N (dB)	32.0	30.5

Differences @ fix	Range (m)	Delay (ns)	Carrier (cycles)	Tracking Availability (%) <th>100</th> <th>100</th>	100	100
- Calculated 1-way	437.264	1458.556	3516.886	- Magnitude	7061	6171
- Calculated 2-way	874.528	2917.111	7033.771	- RF Gain (2*dB)	127	64
				- RF Gain (Non-Coasted) (2*dB)	127	64
				- FR (m)	5895416.467	1.032
				- ICP (cycles)	-574792.629	-578308.969
				- Doppler (Hz)	-5.815	-5.437
				- Phase (cycles)	0.496	0.155
				- Phase Inverted (current)	No	Yes
				- Phase Inverted (locked)	No	Yes
				- Inversion Checked	Yes	Yes
				- Rx Channel ID	13	5
				- LocataLite Int. Temp (C)	41	49
				- Oscillator Freq Offset (ppb)	16	-2

Stats

Stats	Range (m)	Delay (ns)	Carrier (cycles)
- ICP Difference (peak-peak)	0.031	0.103	0.249
- ICP Difference (stdev)	0.006	0.021	0.052
- FR Difference (peak-peak)	0.600	2.003	4.829
- FR Difference (stdev)	0.114	0.381	0.918
- Data Inv Diff Change Count	0		

Figure 6-1: TimeLoc Status Web Page from End-Node LocataLite JRC-2

6.1.2 T2A – Copper/Coax Cable

6.1.2.1 Locata Internal Time Transfer

A small 150ps aberration was observed at approximately the same time of day in tests T2A and T2D. This correlated with early morning sun shining through the laboratory window onto test equipment. We speculate that there was some residual thermal effect due to radiant heating.

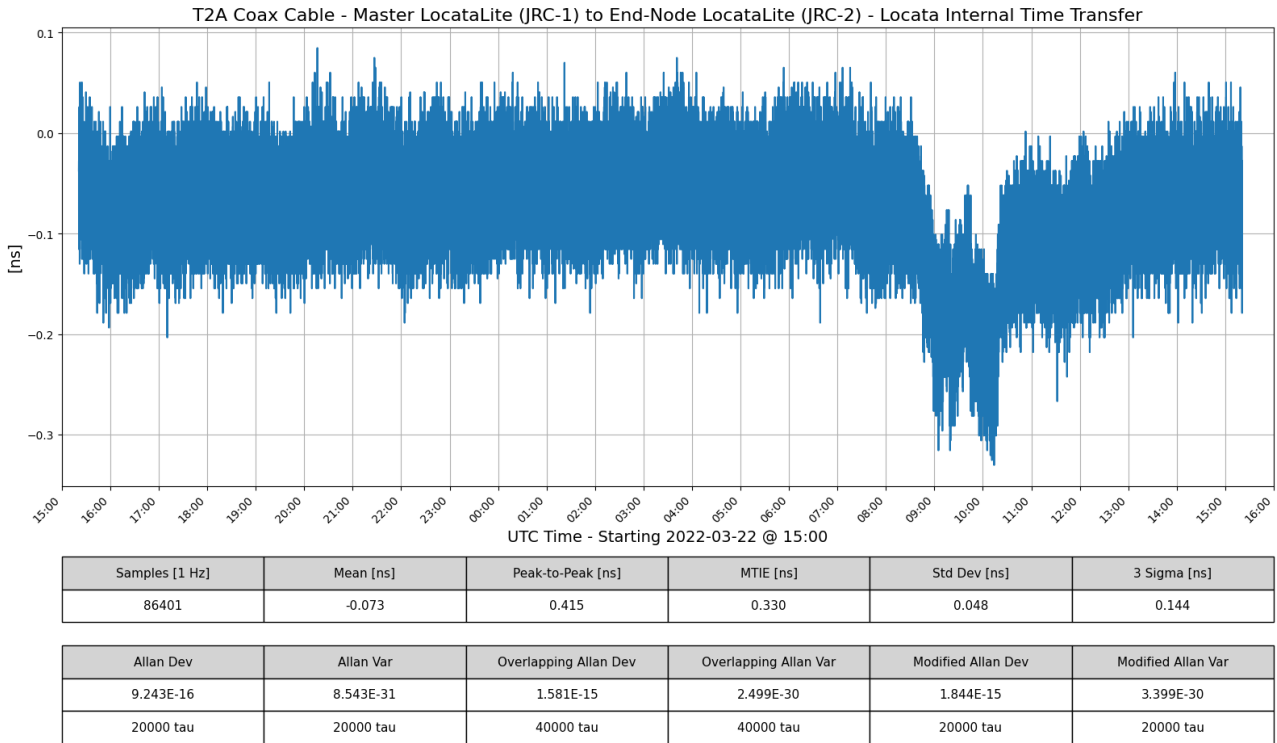

Figure 6-2: T2A Locata Internal Time Transfer Time Series Plot

6.1.2.2 Locata External Time Synchronization

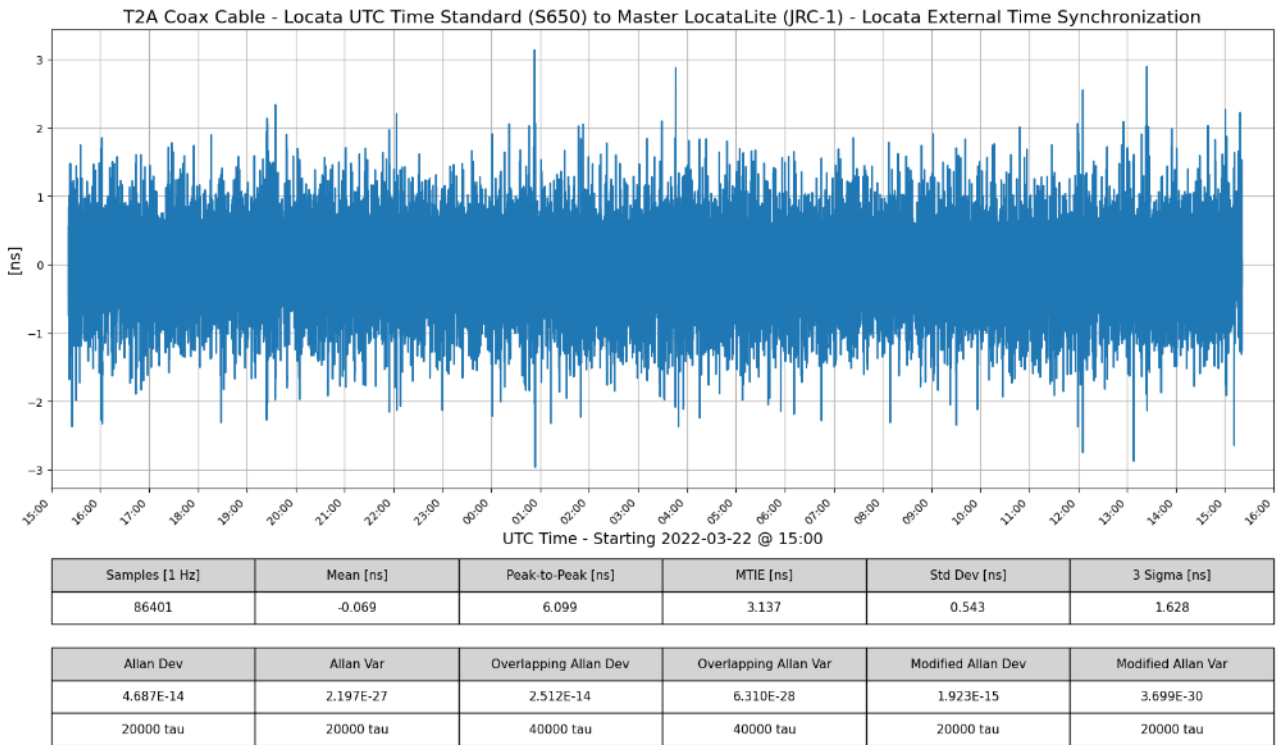

Figure 6-3: T2A Locata External Time Synchronization Time Series Plot

6.1.2.3 Locata External Time Transfer

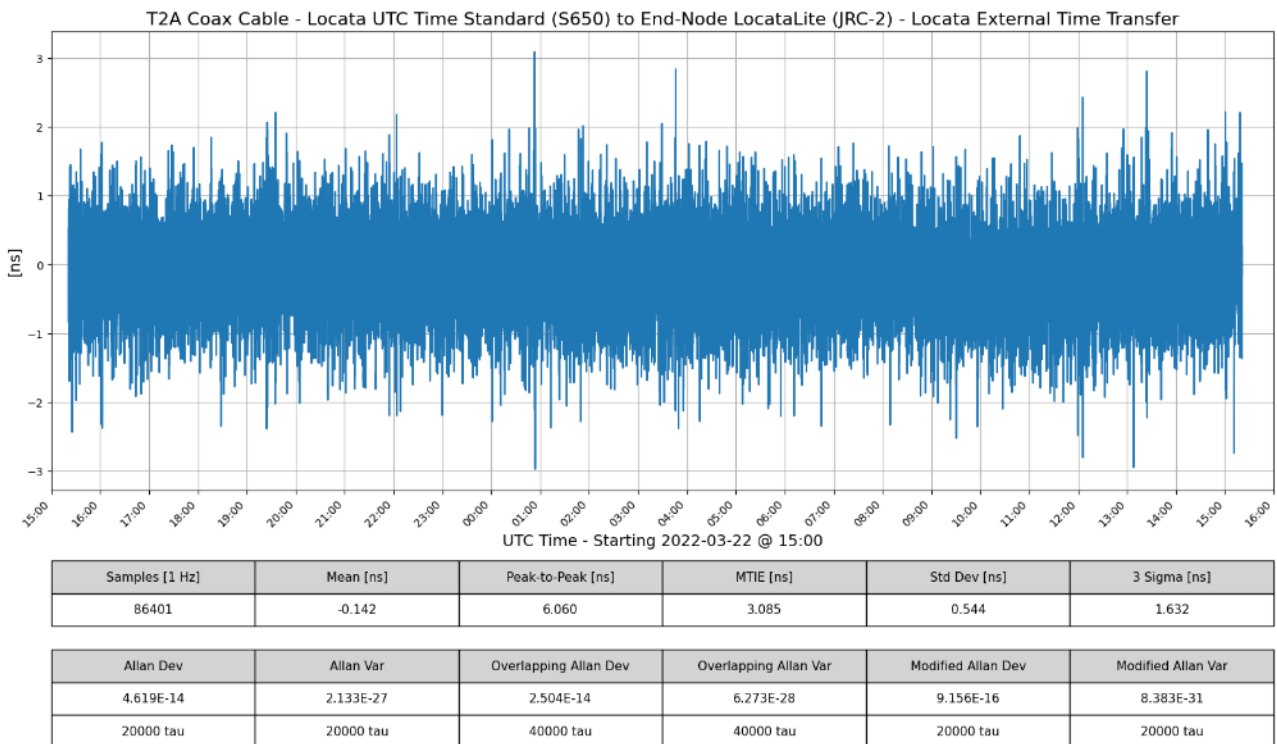

Figure 6-4: T2A Locata External Time Transfer Time Series Plot

6.1.2.4 Locata to UTC Comparison & Clock Comparison

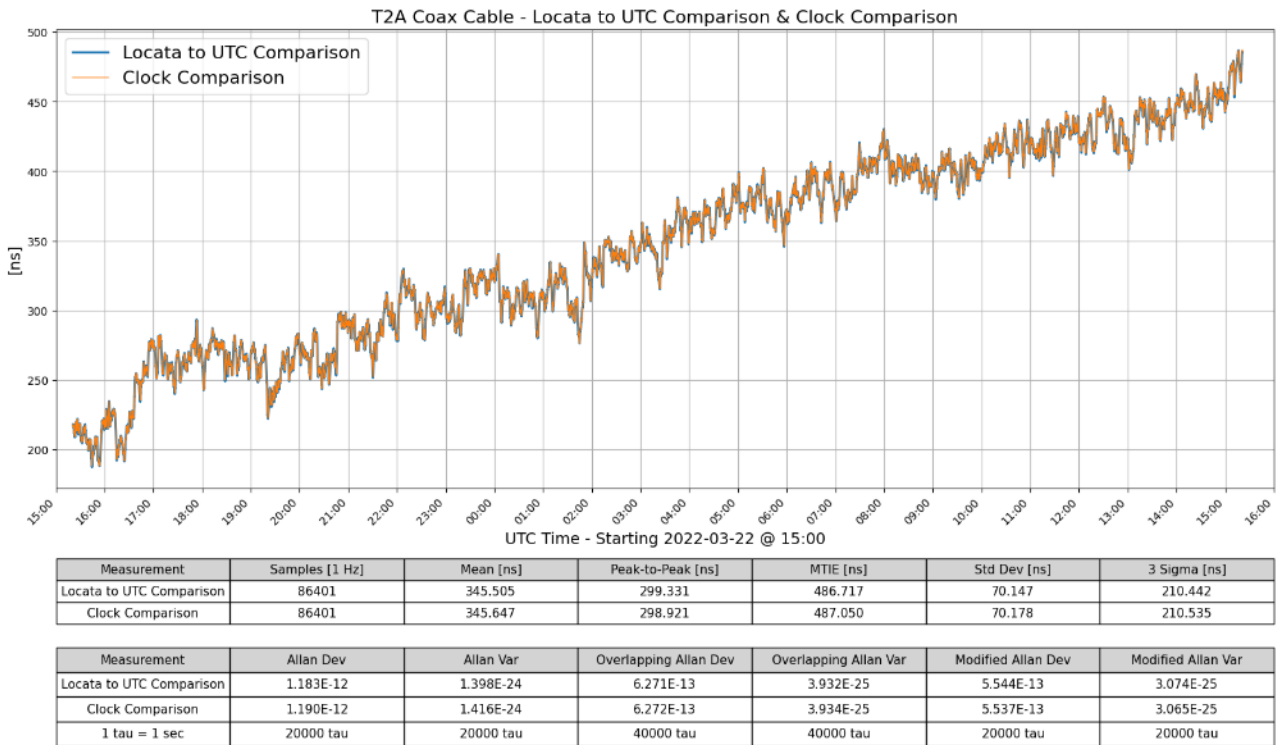

Figure 6-5: T2A Locata to UTC Comparison & Clock Comparison Time Series Plot

6.1.2.5 Measured Link Adjustments

The measured link adjustments shows 6.7 ps (2 mm) of variation up to an event at 14:00 UTC. A sudden negative offset of 60 ps (18 mm) was observed followed by a positive offset of 57 ps (17 mm) several minutes later. This event is consistent with a half-cycle carrier slip followed by a TimeLoc link adjustment to correct the error. The magnitude of the event is also too small to register in the plot of Locata Internal Time Transfer.

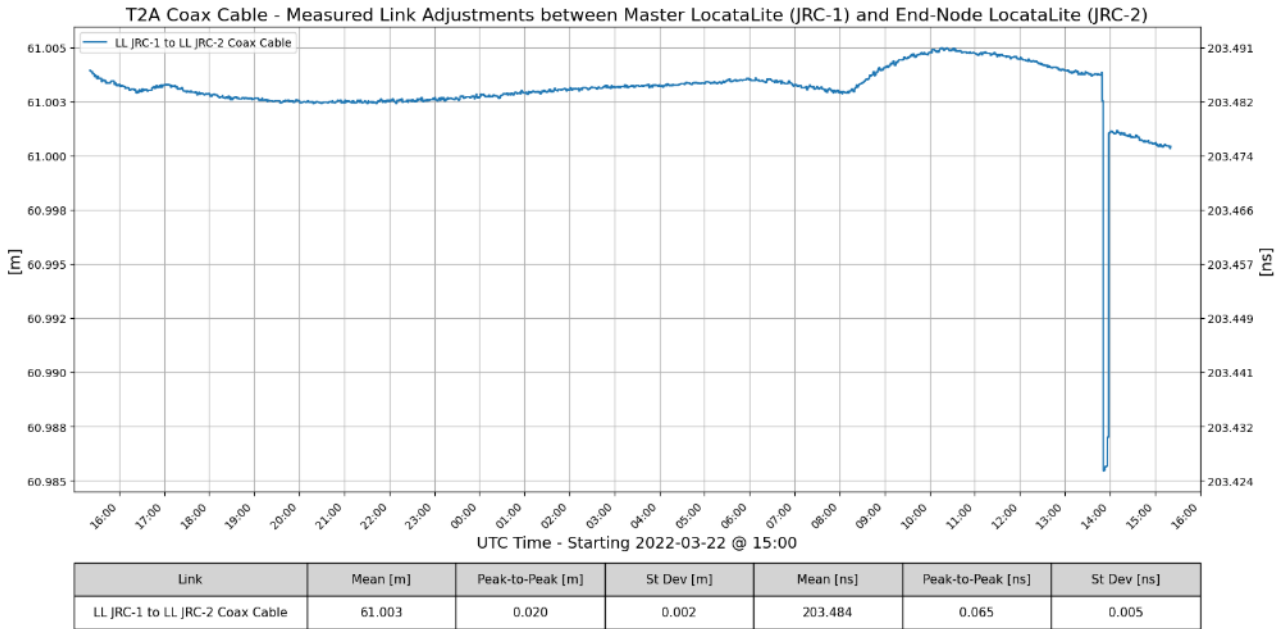

Figure 6-6: T2A Measured Link Adjustments

6.1.3 T2B – OTA Indoor

6.1.3.1 Locata Internal Time Transfer

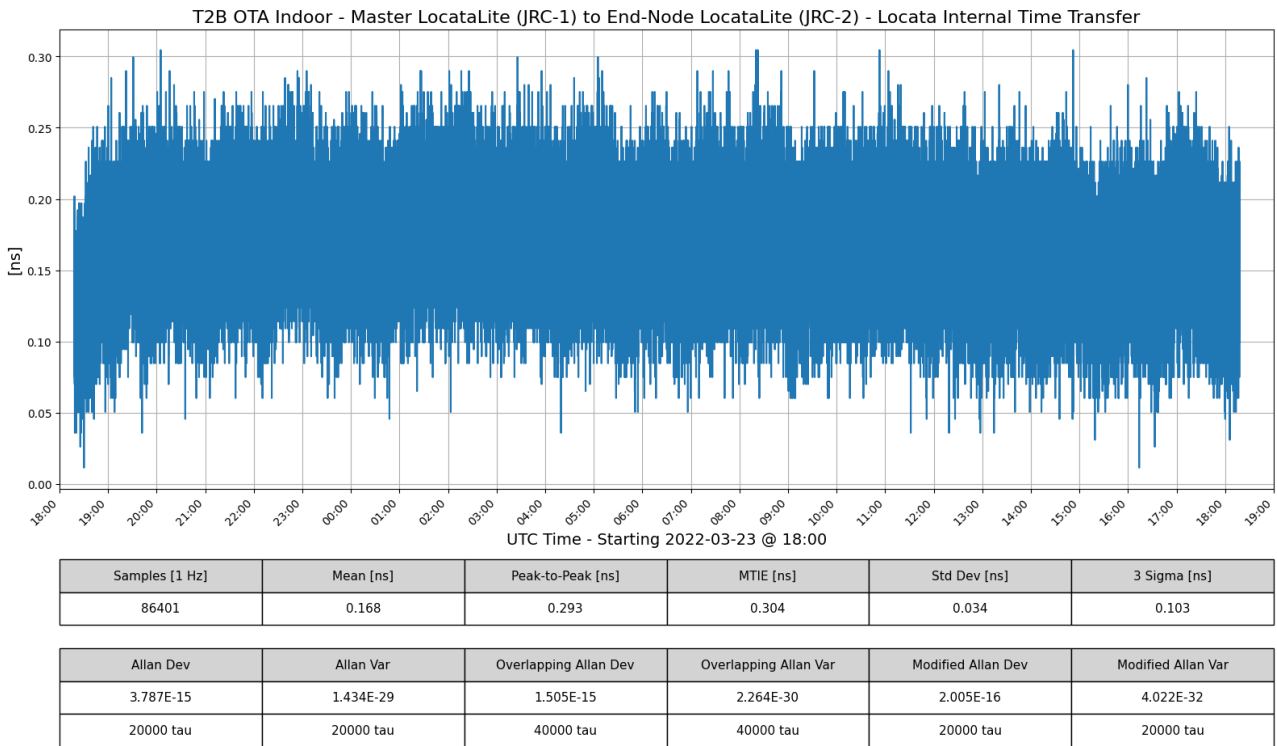

Figure 6-7: T2B Locata Internal Time Transfer Time Series Plot

6.1.3.2 Locata External Time Synchronization

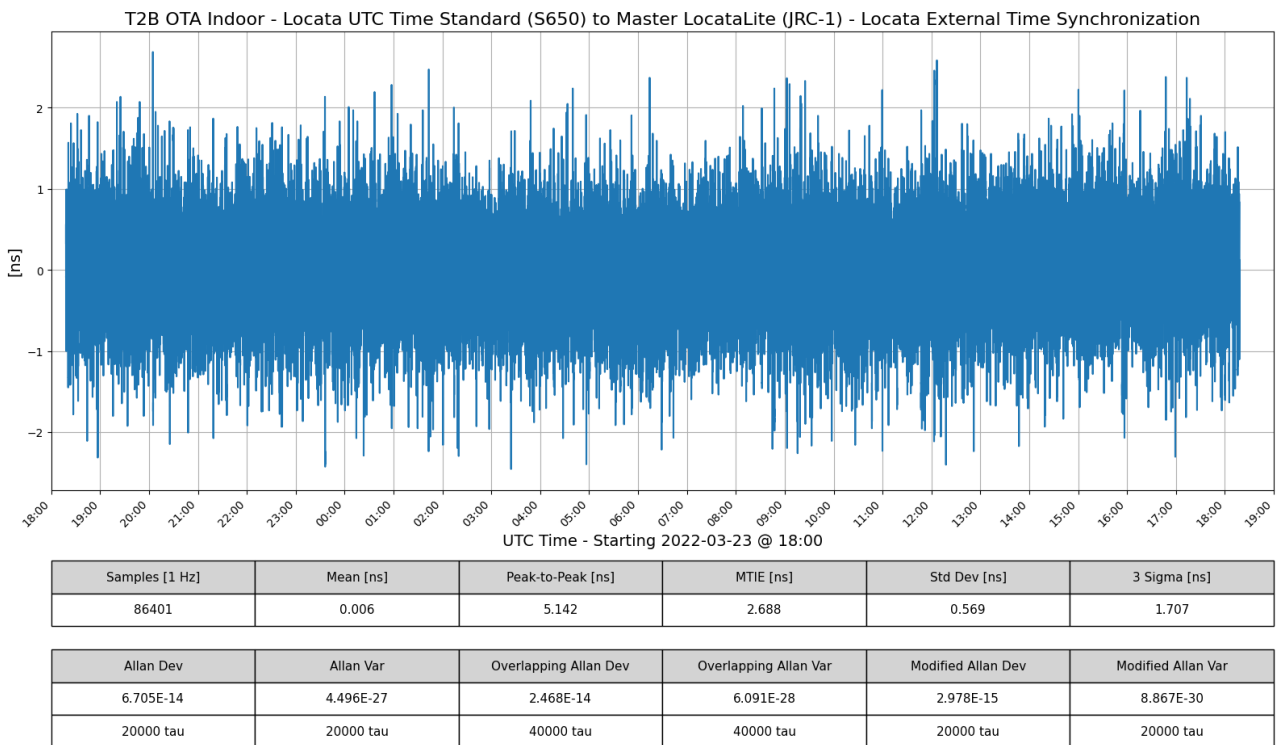

Figure 6-8: T2B Locata External Time Synchronization Time Series Plot

6.1.3.3 Locata External Time Transfer

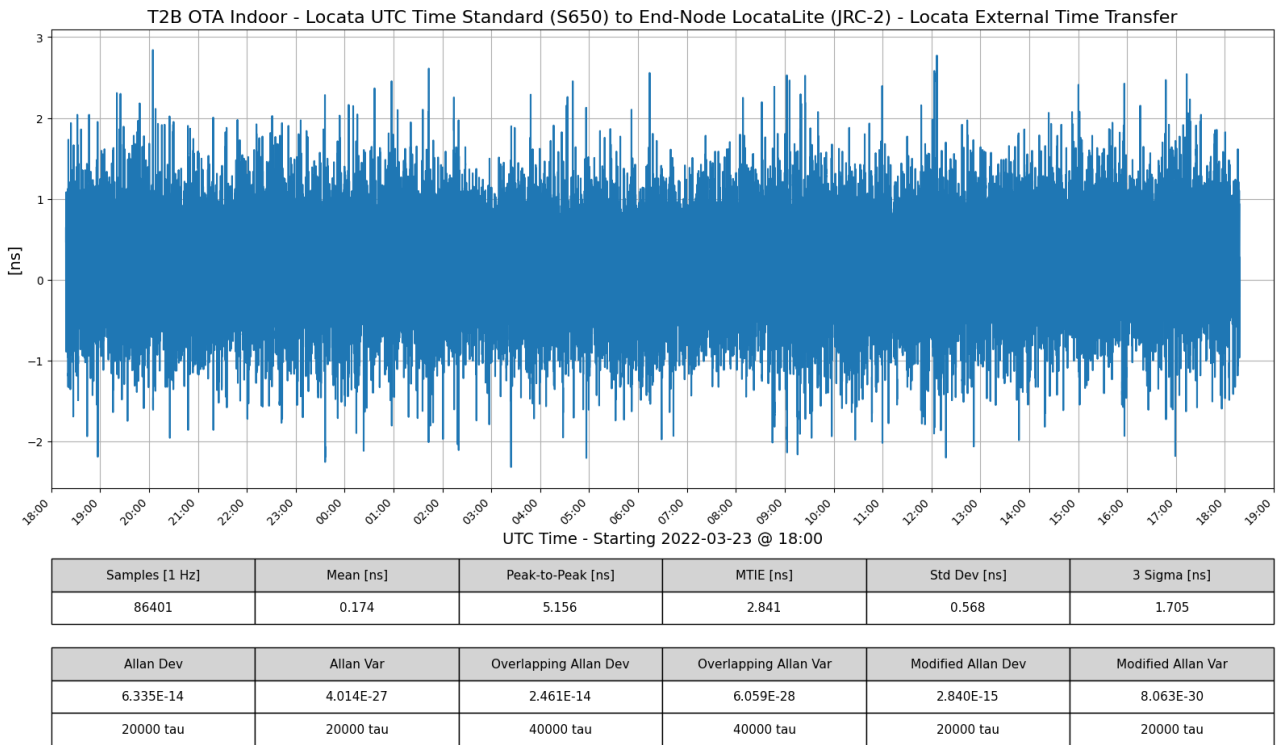

Figure 6-9: T2B Locata External Time Transfer Time Series Plot

6.1.3.4 Locata to UTC Comparison & Clock Comparison

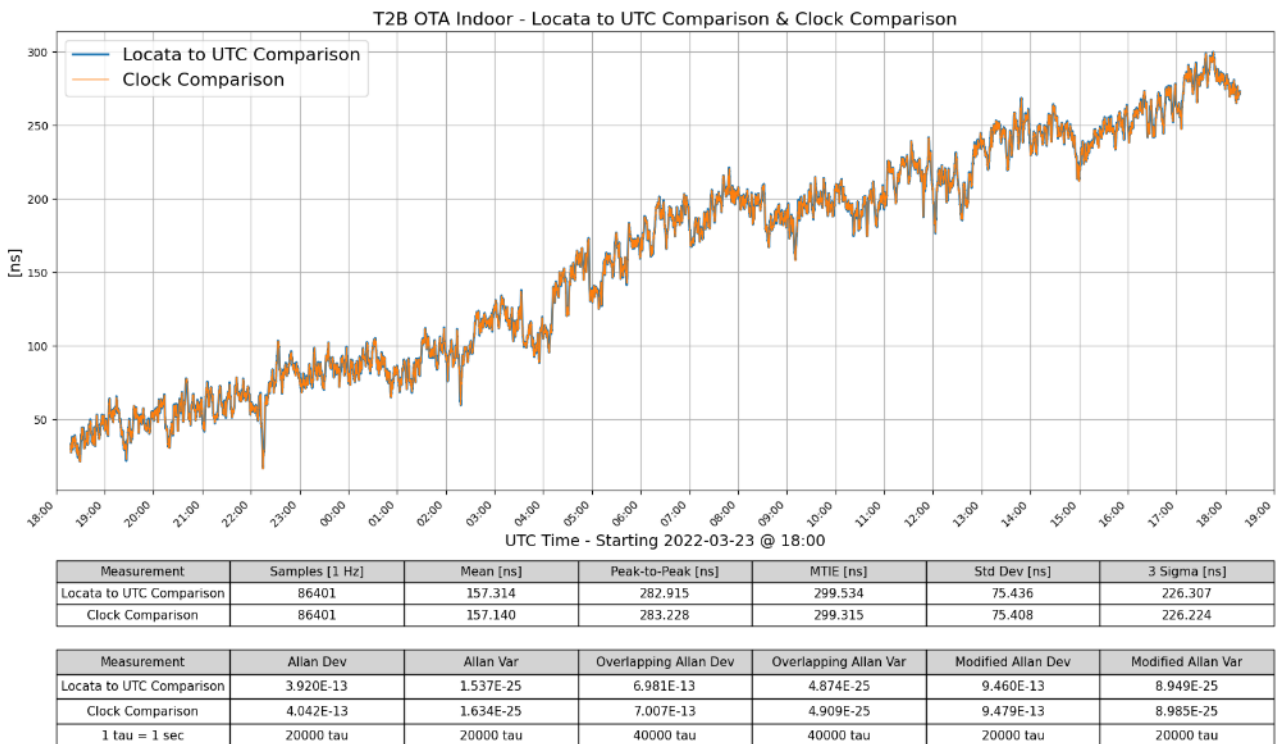

Figure 6-10: T2B Locata to UTC Comparison & Clock Comparison Time Series Plot

6.1.3.5 Measured Link Adjustments

The measured link adjustments shows less than 6.7 ps (2 mm) of variation over the entire 24 hours.

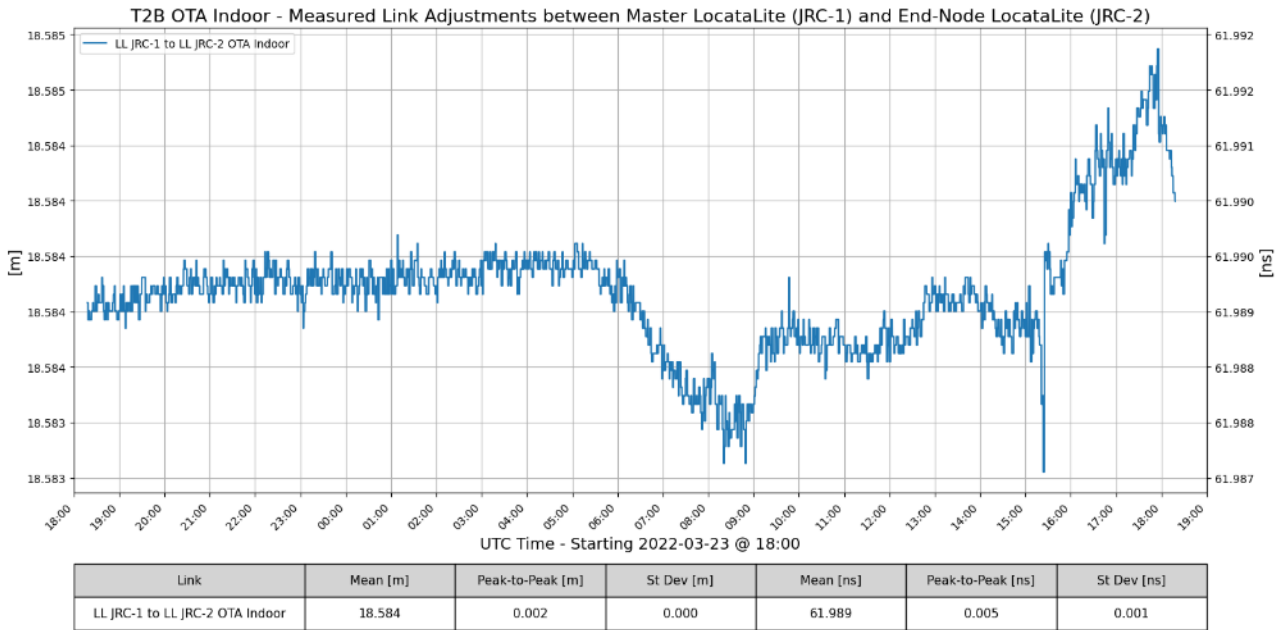

Figure 6-11: T2B Measured Link Adjustments

6.1.4 T2C – OTA Outdoor Local Area

6.1.4.1 Locata Internal Time Transfer

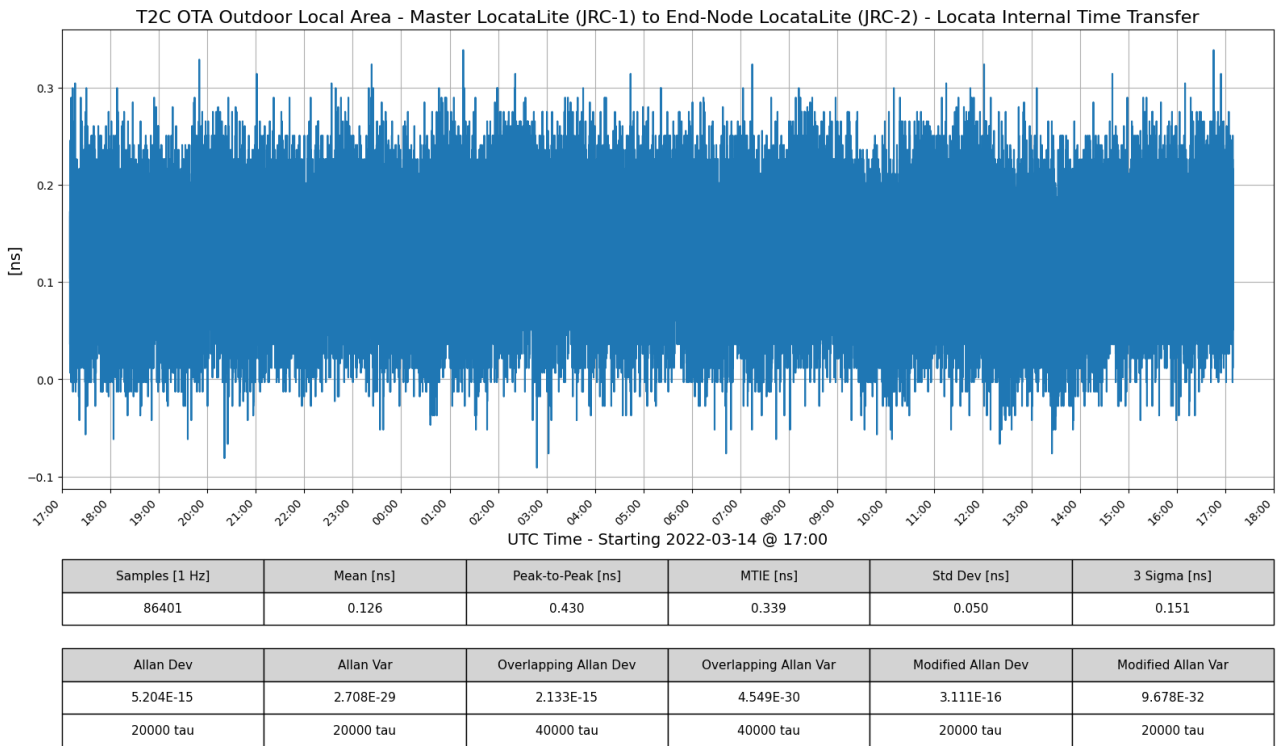

Figure 6-12: T2C Locata Internal Time Transfer Time Series Plot

6.1.4.2 Locata External Time Synchronization

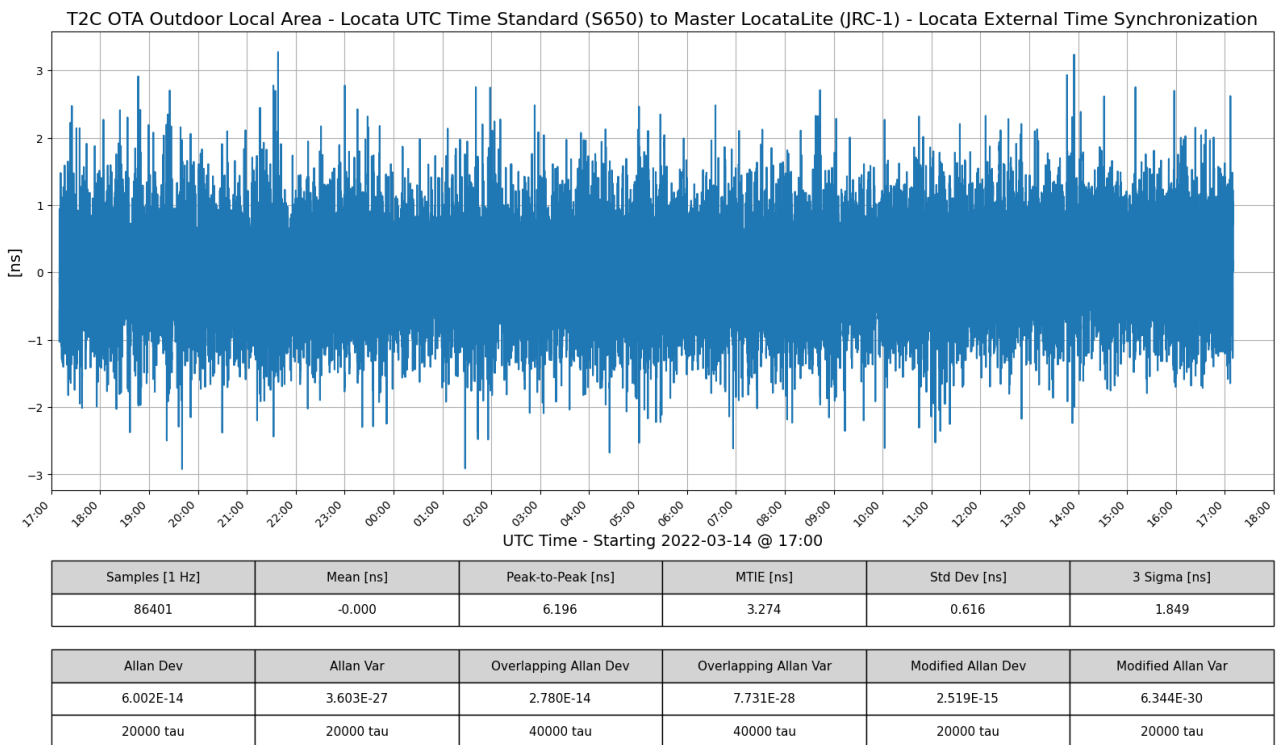

Figure 6-13: T2C Locata External Time Synchronization Time Series Plot

6.1.4.3 Locata External Time Transfer

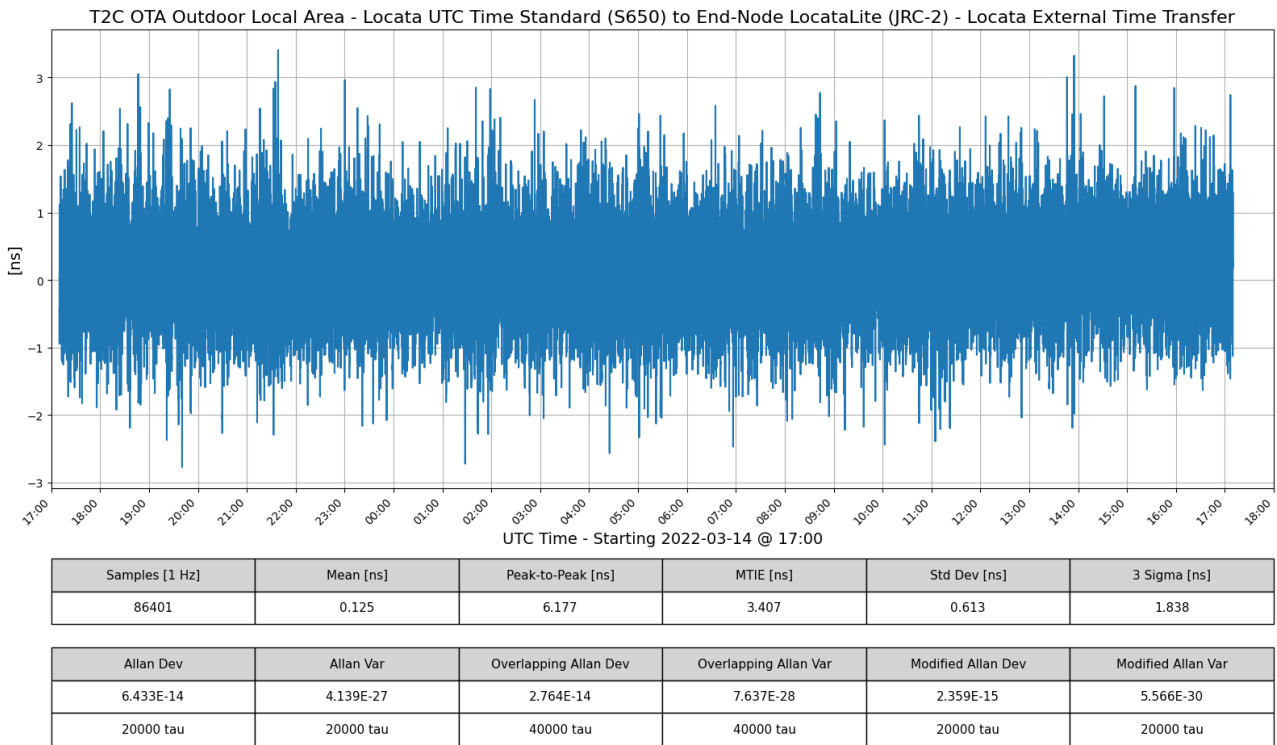

Figure 6-14: T2C Locata External Time Transfer Time Series Plot

6.1.4.4 Locata to UTC Comparison & Clock Comparison

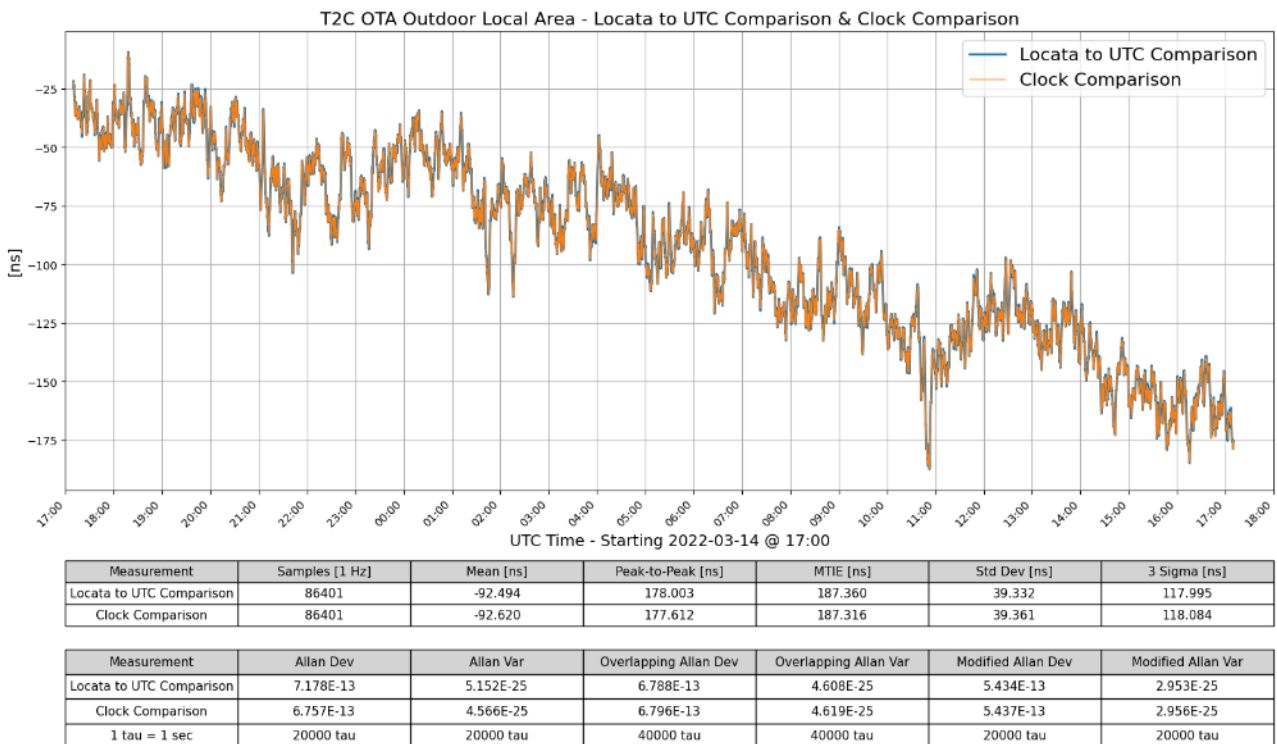

Figure 6-15: T2C Locata to UTC Comparison & Clock Comparison Time Series Plot

6.1.4.5 Measured Link Adjustments

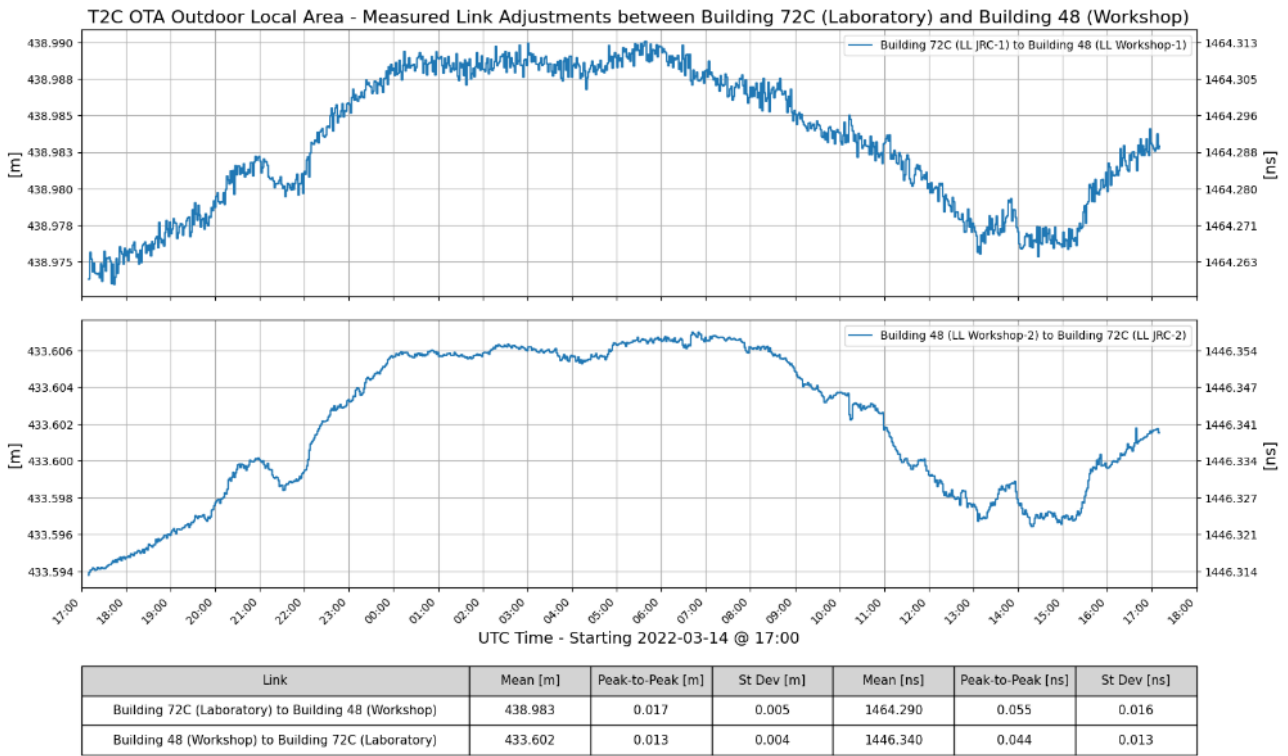

Figure 6-16: T2C Measured Link Adjustments between Building 72C (Laboratory) and Building 48 (Workshop)

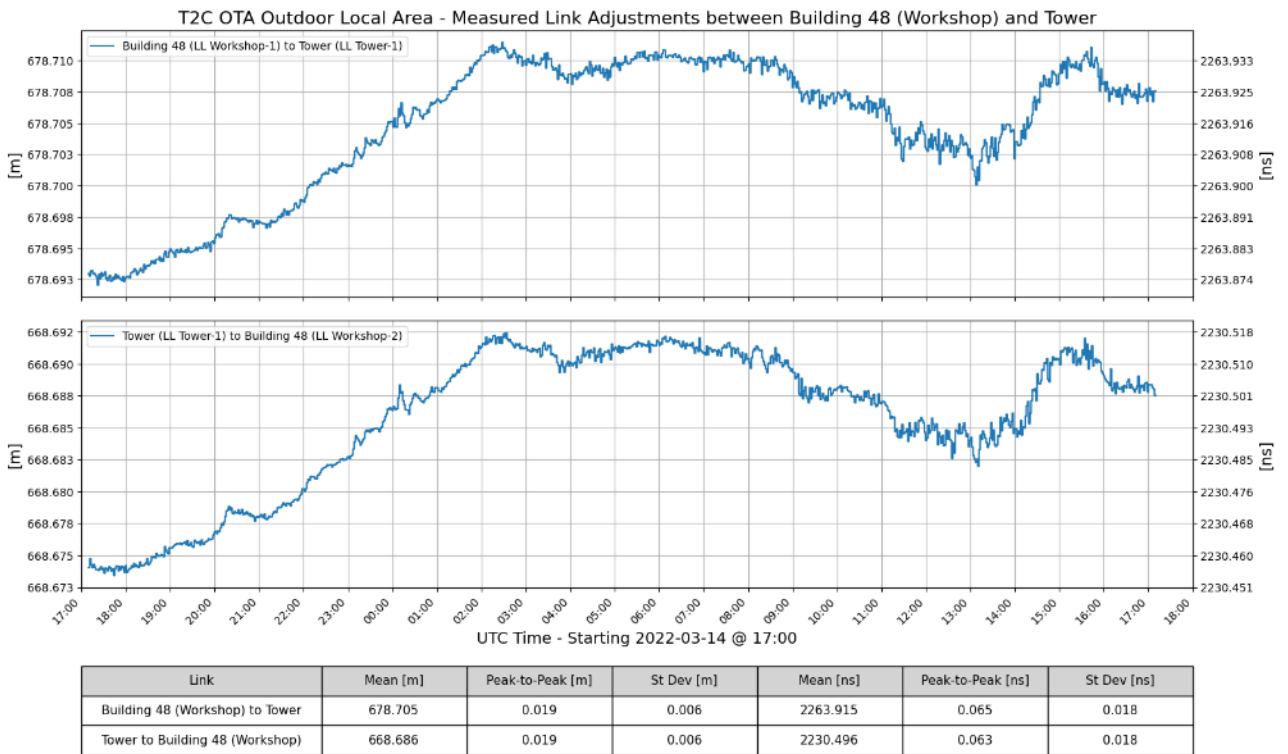

Figure 6-17: T2C Measured Link Adjustments between Building 48 (Workshop) and Tower

The figure below shows total measured link adjustments over all 4 hops (approximately 2.2 km). There was 0.218 ns (6.5 cm) of variation over the 24 hour test period. In contrast, the internal time transfer TIC measurement in Figure 6-12 shows a steady 0.126 ns (3.8cm) mean offset with 0.050 ns (1.5 cm) standard deviation.

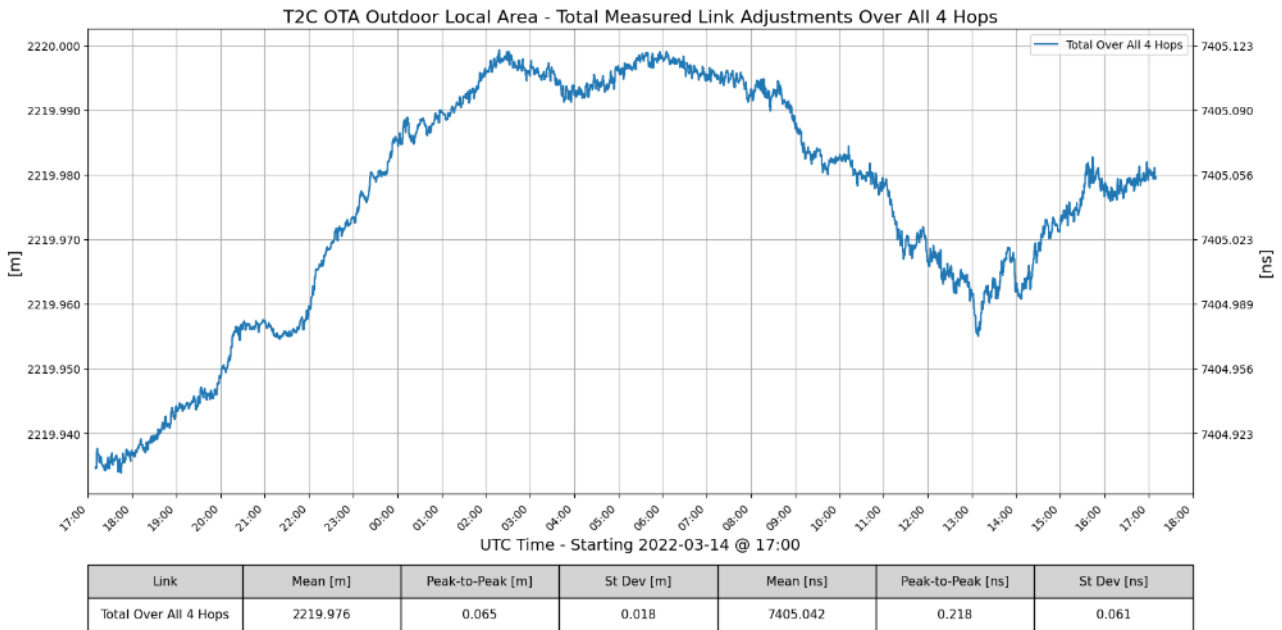

Figure 6-18: T2C Total Measured Link Adjustments Over All 4 Hops

6.1.5 T2D – Fibre Optic

6.1.5.1 Locata Internal Time Transfer

A small 150ps aberration was observed at approximately the same time of day in tests T2A and T2D. This correlated with early morning sun shining through the laboratory window onto test equipment. We speculate that there was some residual thermal effect due to radiant heating.

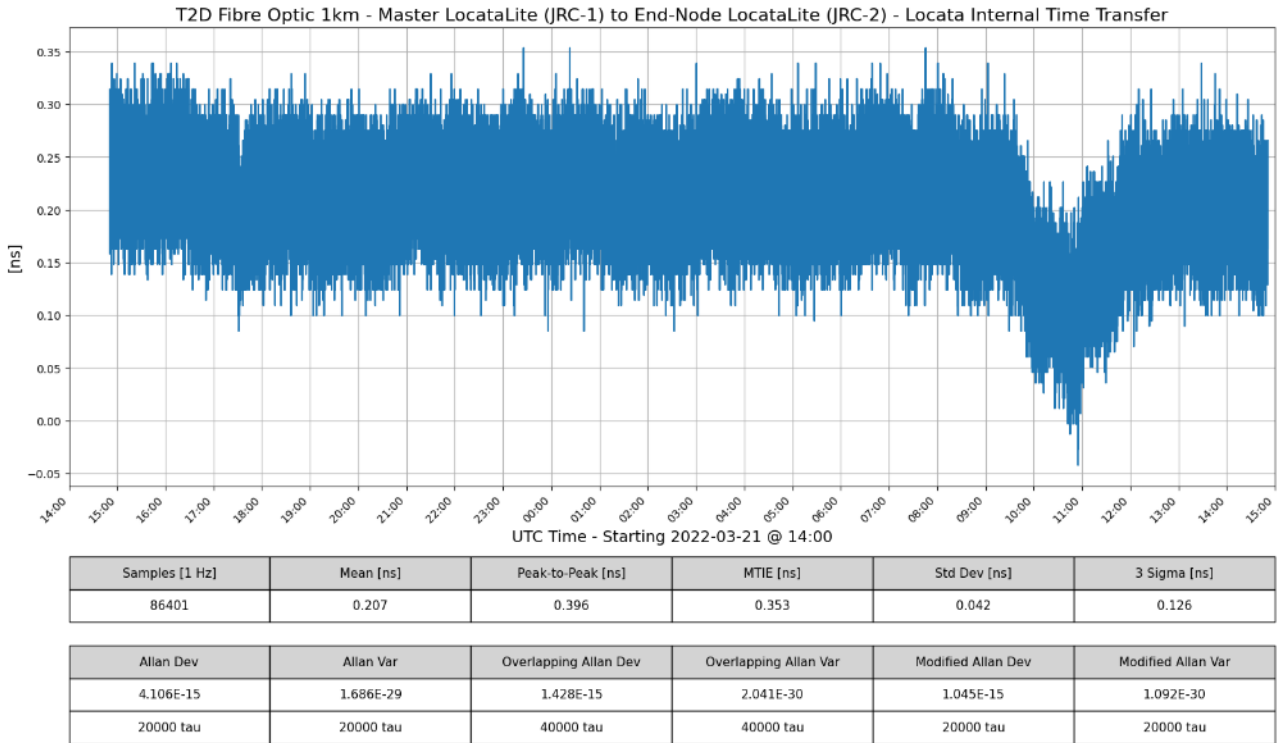

Figure 6-19: T2D Locata Internal Time Transfer Time Series Plot

6.1.5.2 Locata External Time Synchronization

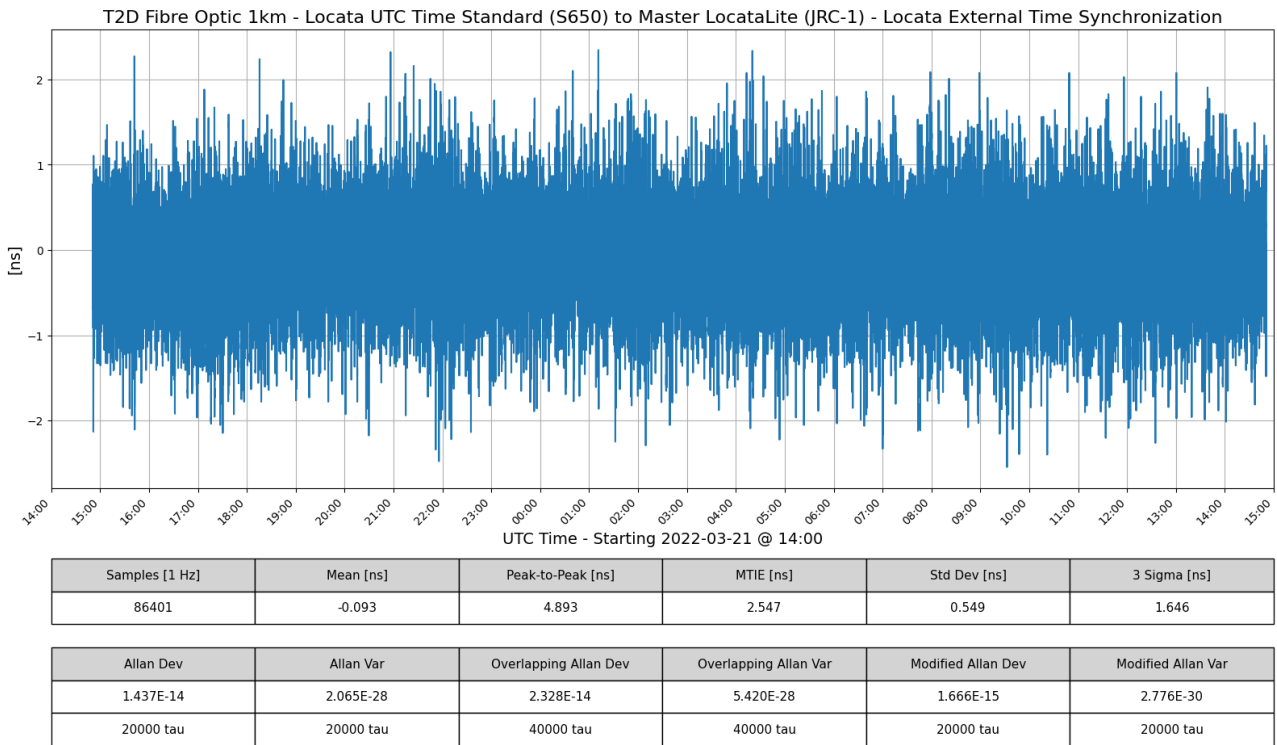

Figure 6-20: T2D Locata External Time Synchronization Time Series Plot

6.1.5.3 Locata External Time Transfer

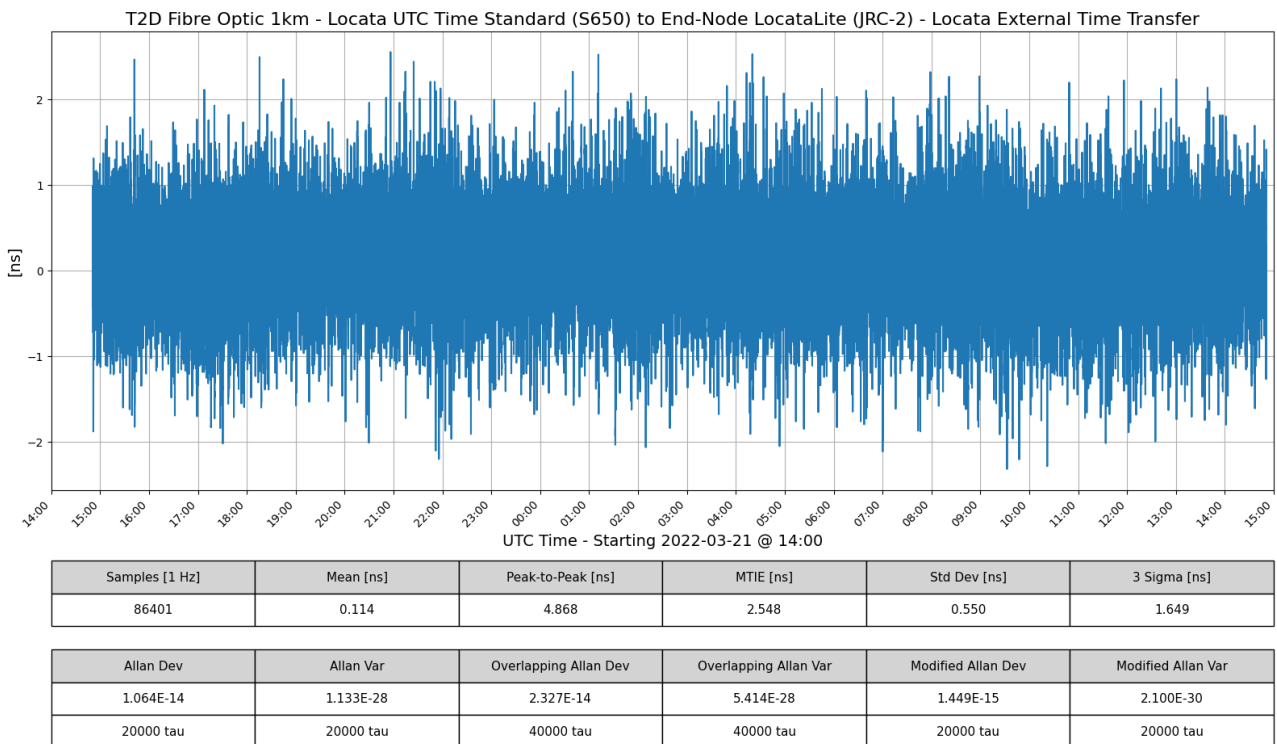

Figure 6-21: T2D Locata External Time Transfer Time Series Plot

6.1.5.4 Locata to UTC Comparison & Clock Comparison

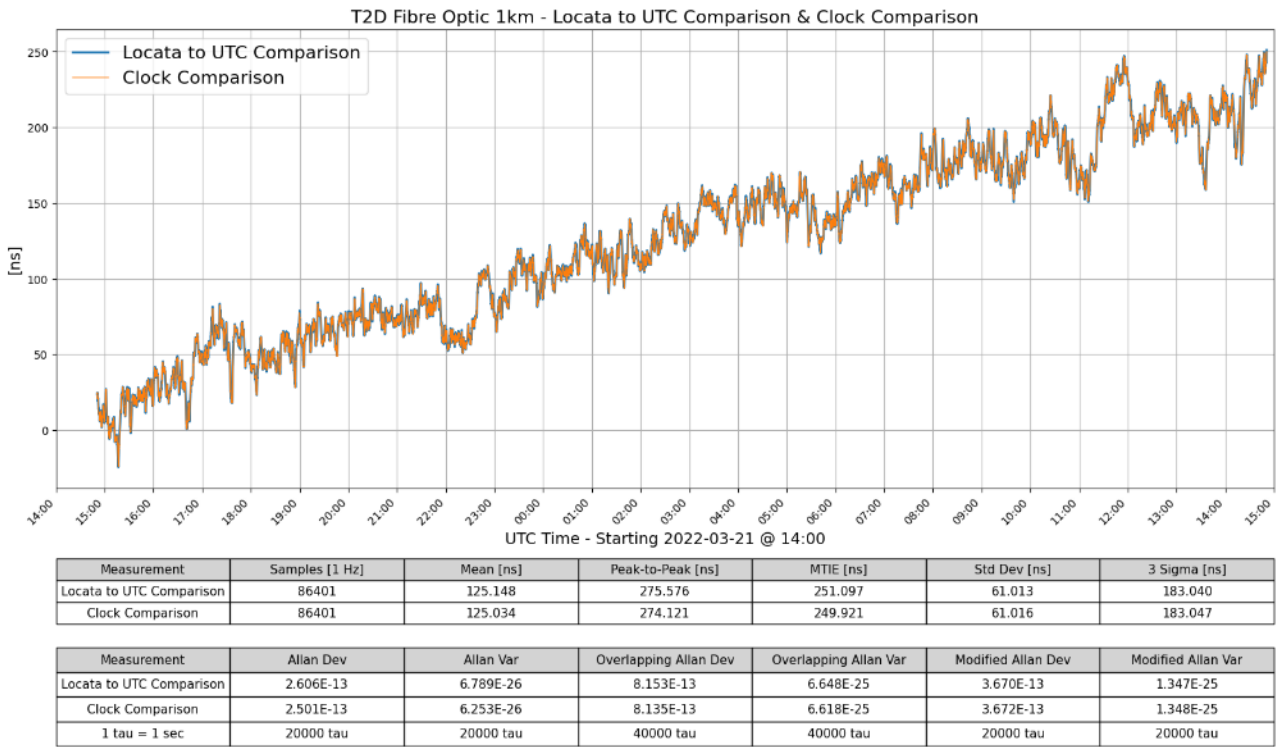

Figure 6-22: T2D Locata to UTC Comparison & Clock Comparison Time Series Plot

6.1.5.5 Measured Link Adjustments

The measured link adjustments show 0.747 ns (22 cm) of variation over 24 hours. Of note is a large adjustment at 08:30 UTC which correlated with the 1km roll of fibre being in direct sunlight through the office window.

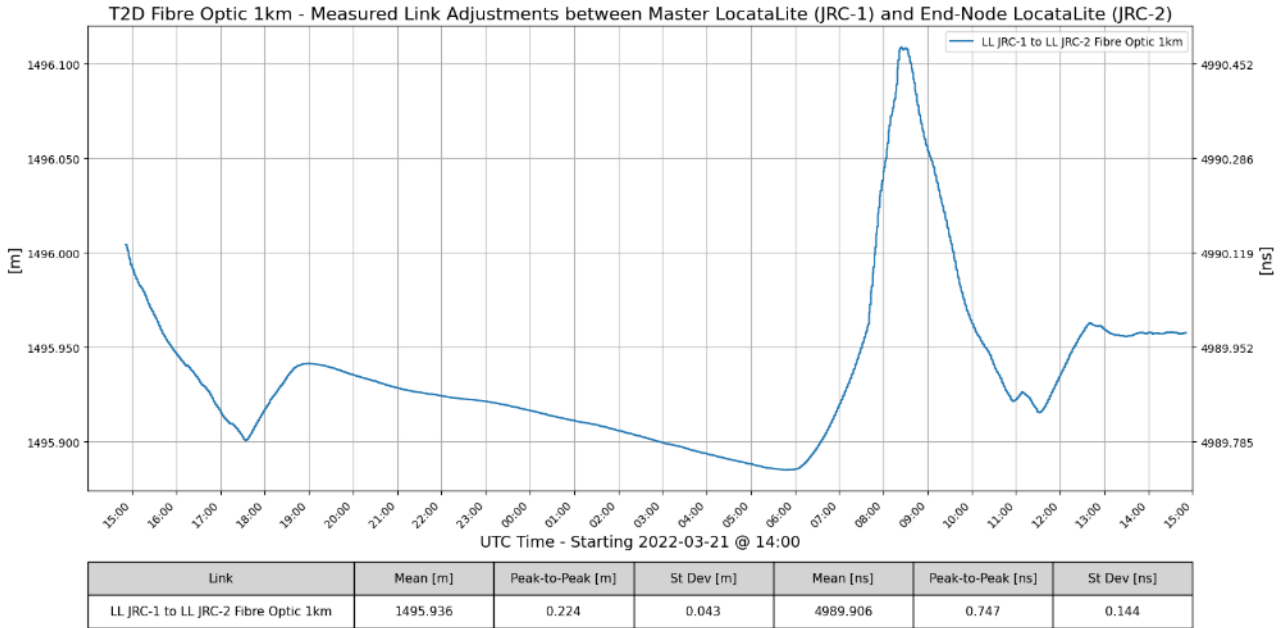

Figure 6-23: T2D Measured Link Adjustments

6.1.6 T2E – OTA Outdoor Wide Area

6.1.6.1 Locata Internal Time Transfer

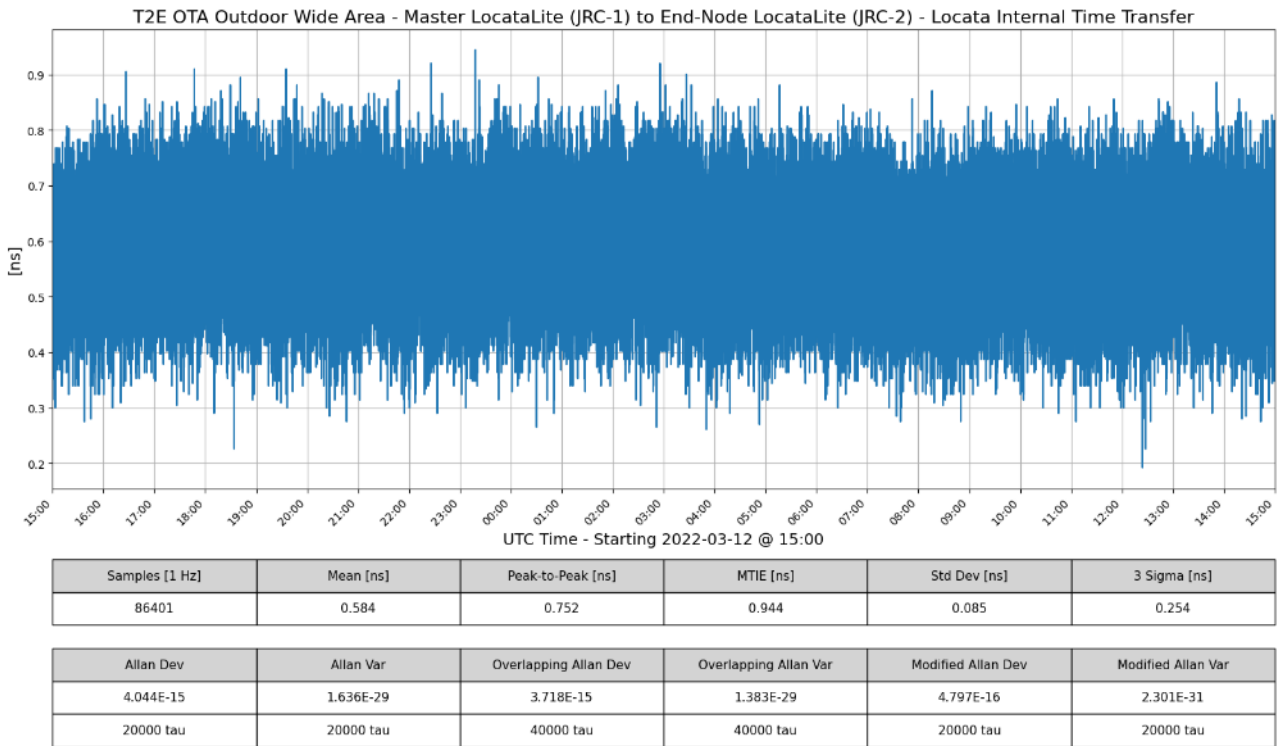

Figure 6-24: T2E Locata Internal Time Transfer Time Series Plot

6.1.6.2 Locata External Time Synchronization

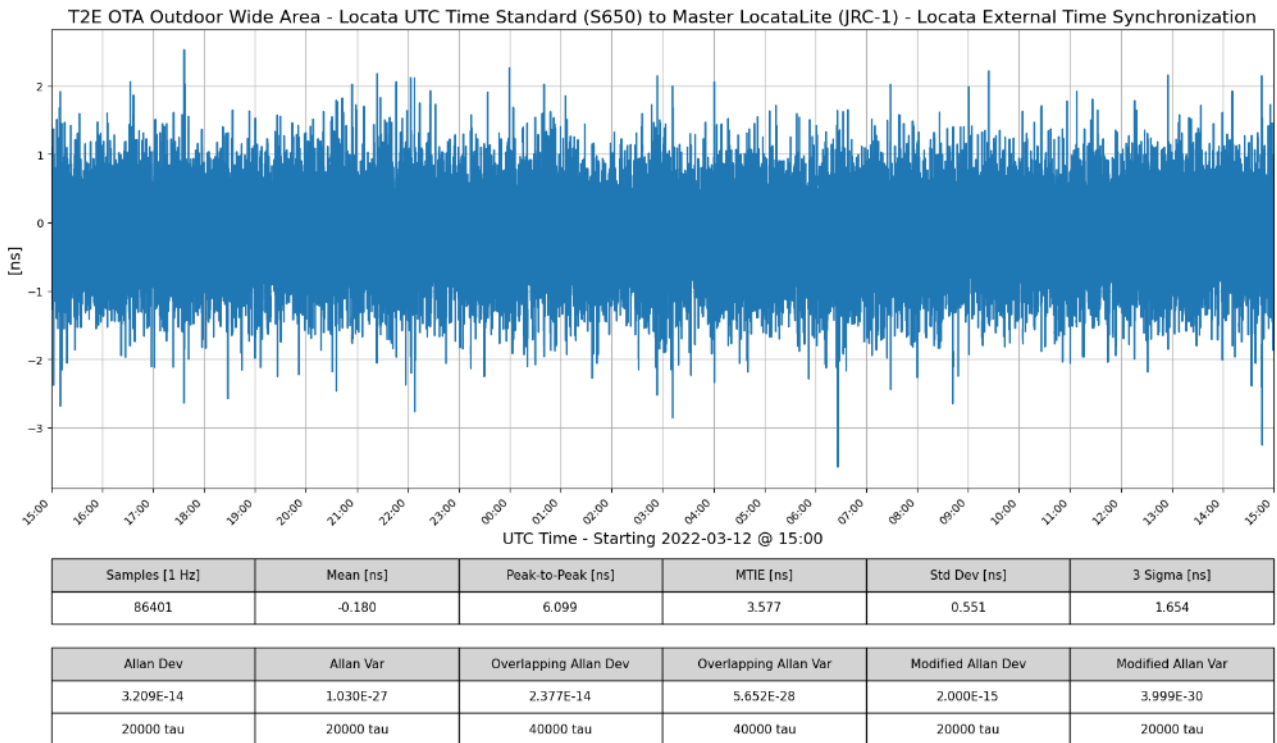

Figure 6-25: T2E Locata External Time Synchronization Time Series Plot

6.1.6.3 Locata External Time Transfer

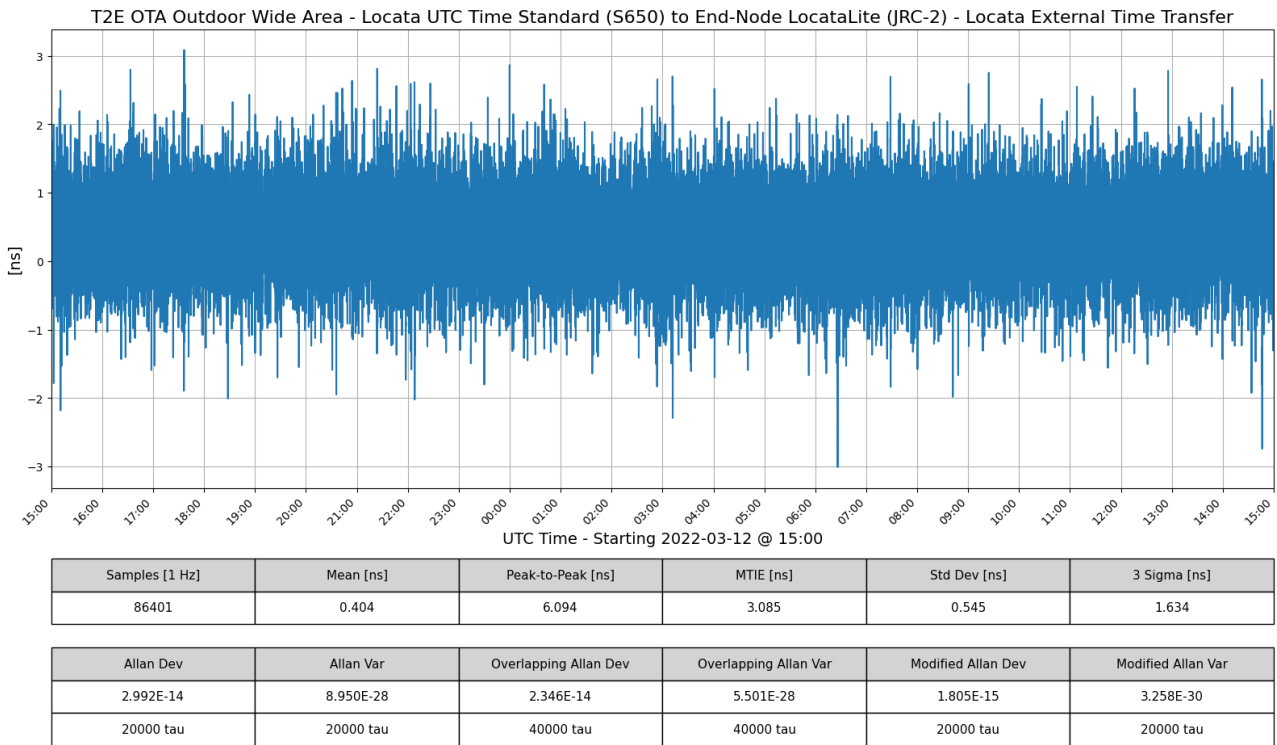

Figure 6-26: T2E Locata External Time Transfer Time Series Plot

6.1.6.4 Locata to UTC Comparison & Clock Comparison

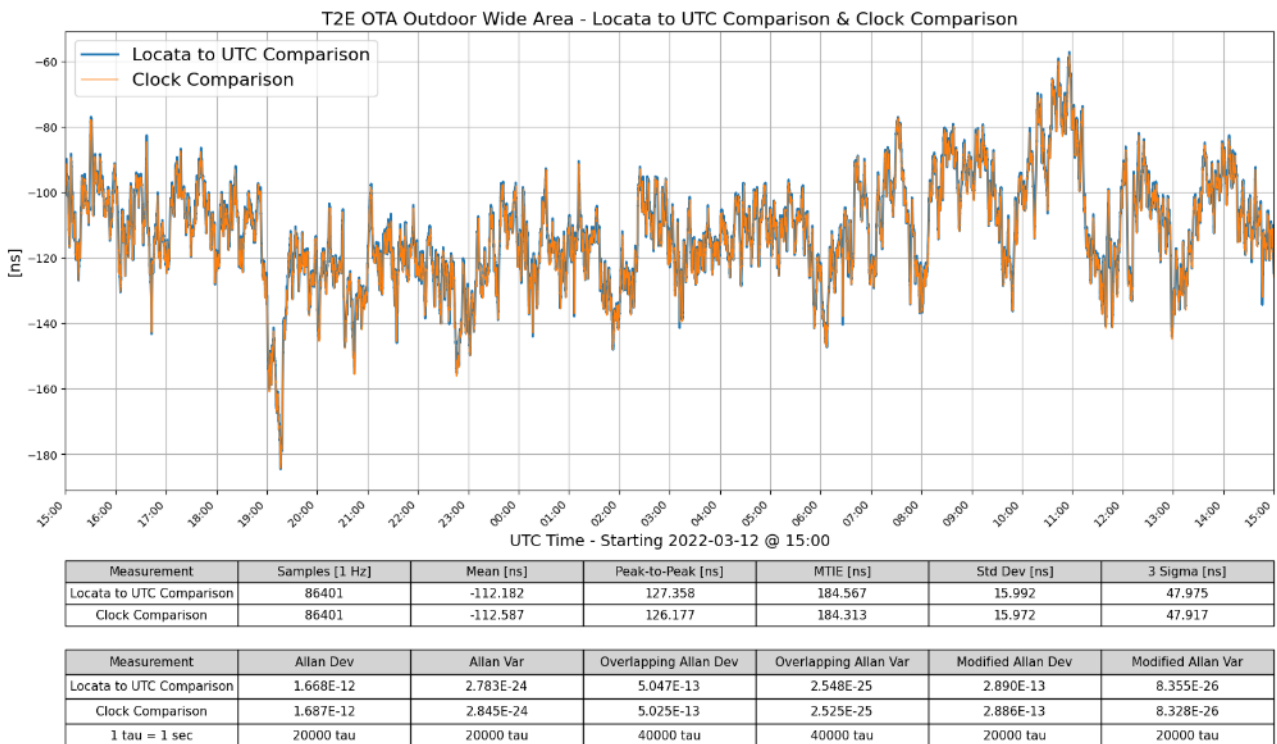

Figure 6-27: T2E Locata to UTC Comparison & Clock Comparison Time Series Plot

6.1.6.5 Measured Link Adjustments

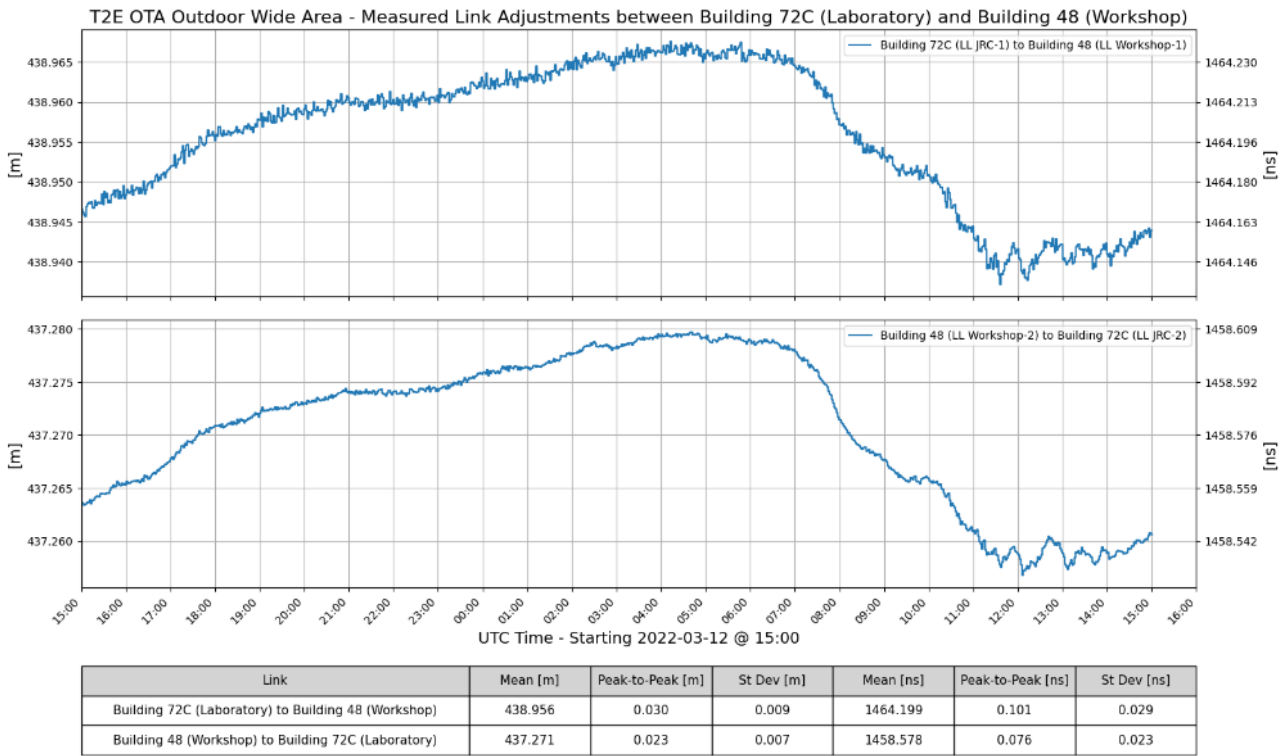

Figure 6-28: T2E Measured Link Adjustments Between Building 72C (Laboratory) and Building 48 (Workshop)

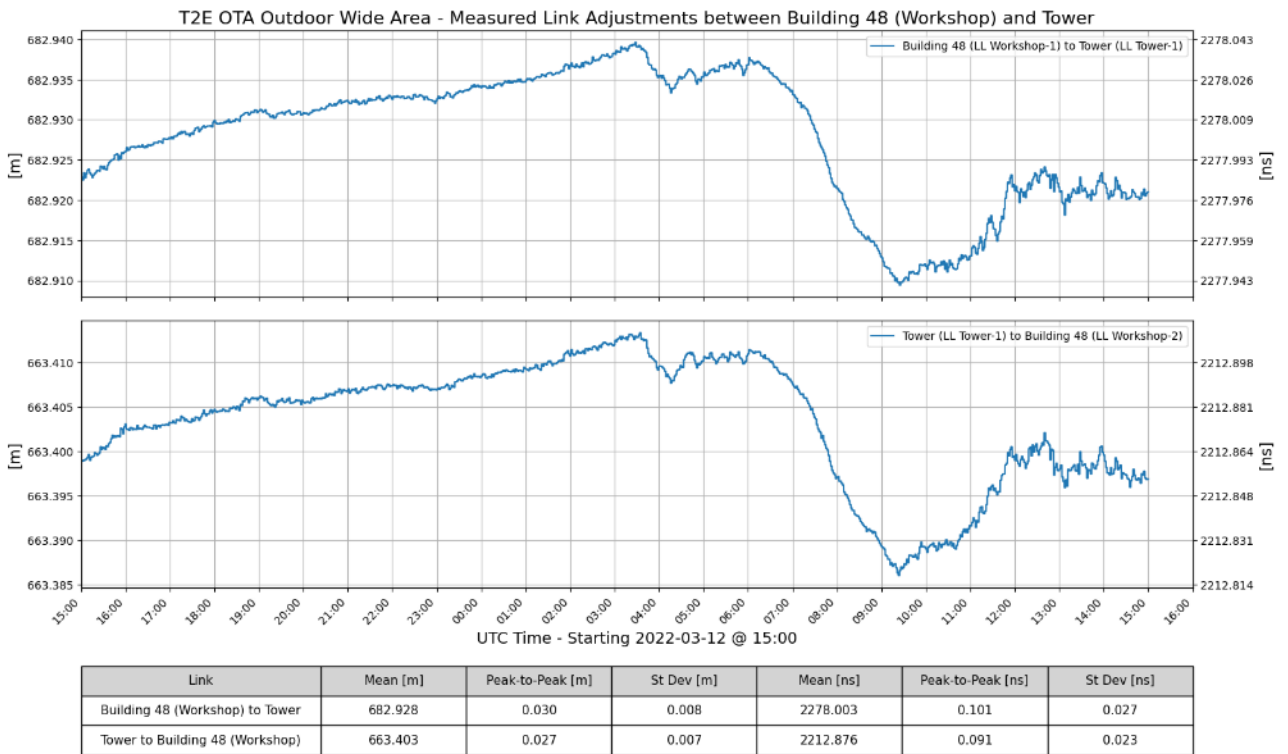

Figure 6-29: T2E Measured Link Adjustments Between Building 48 (Workshop) and Tower

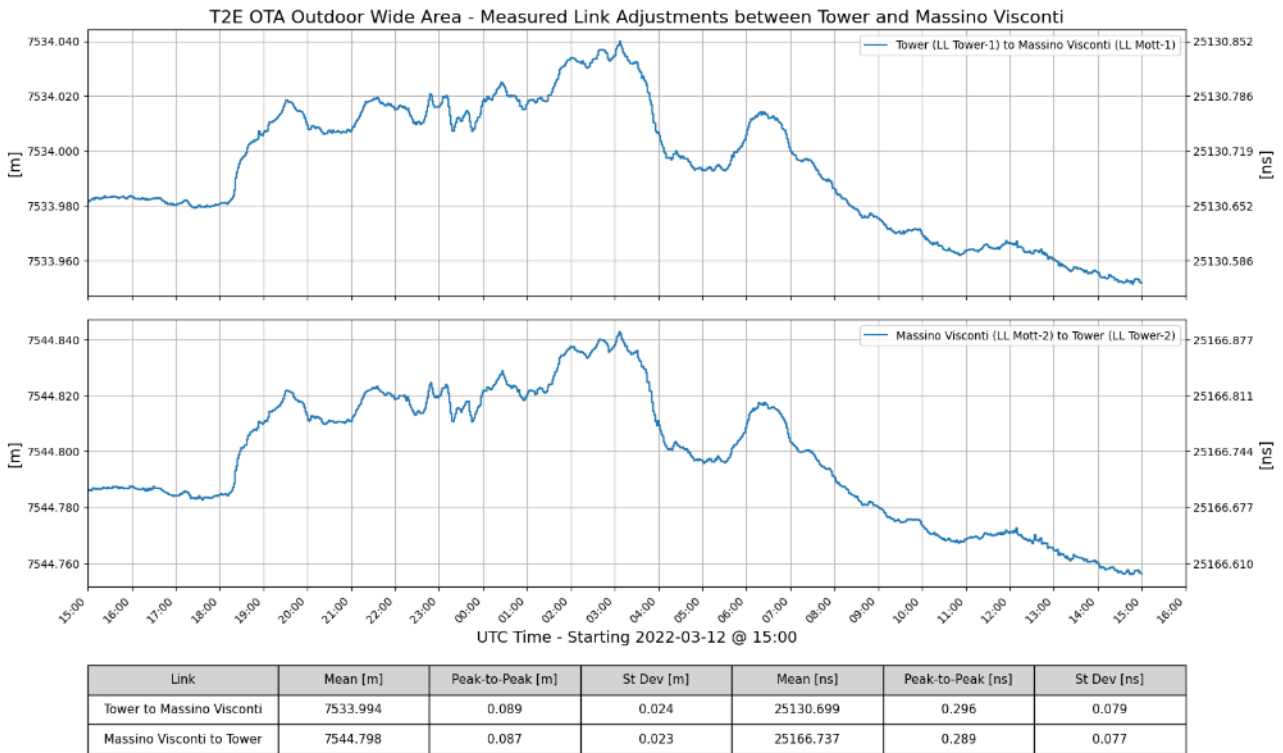

Figure 6-30: T2E Measured Link Adjustments Between Tower and Massino Visconti

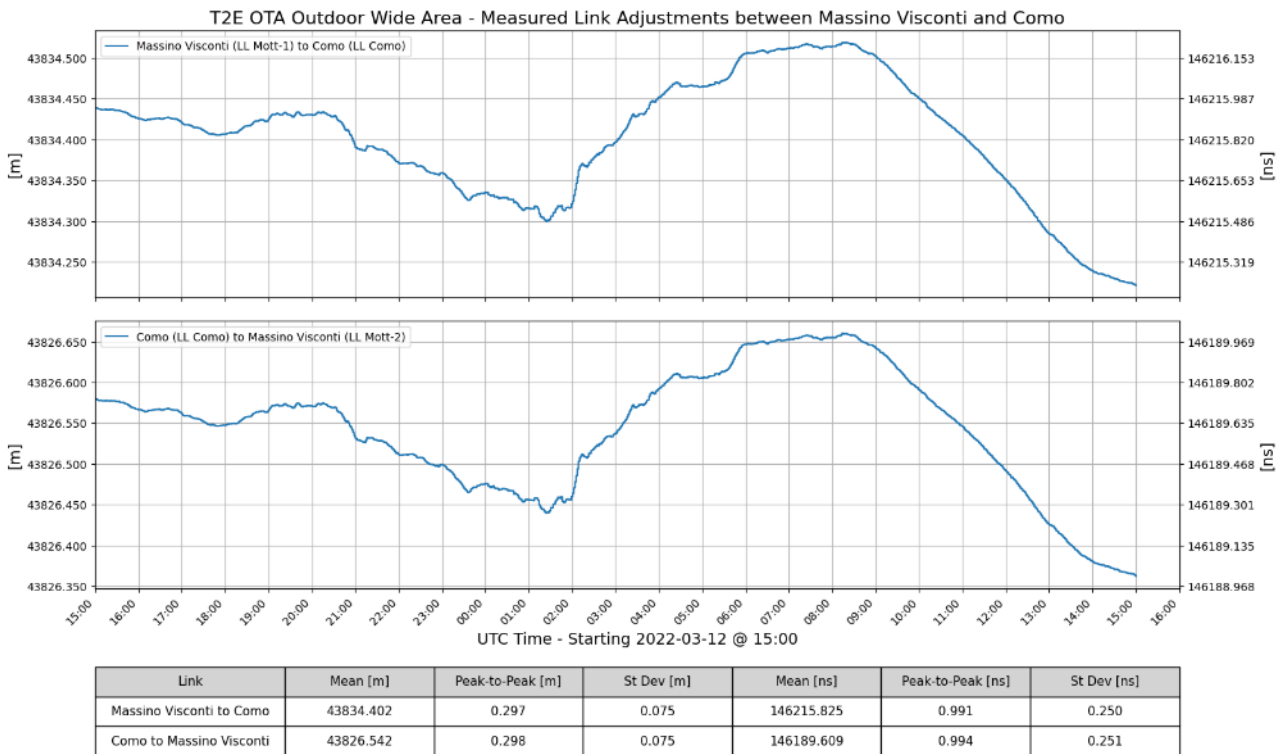

Figure 6-31: T2E Measured Link Adjustments Between Massino Visconti and Como

The figure below shows total measured link adjustments over all 8 hops (approximately 105 km). There was just over 2.5 ns (77 cm) of variation over the 24 hour test period. In contrast, the internal time transfer TIC measurement in Figure 6-24 shows a steady 0.584 ns (17cm) mean offset with 0.085 ns (2.5 cm) standard deviation.

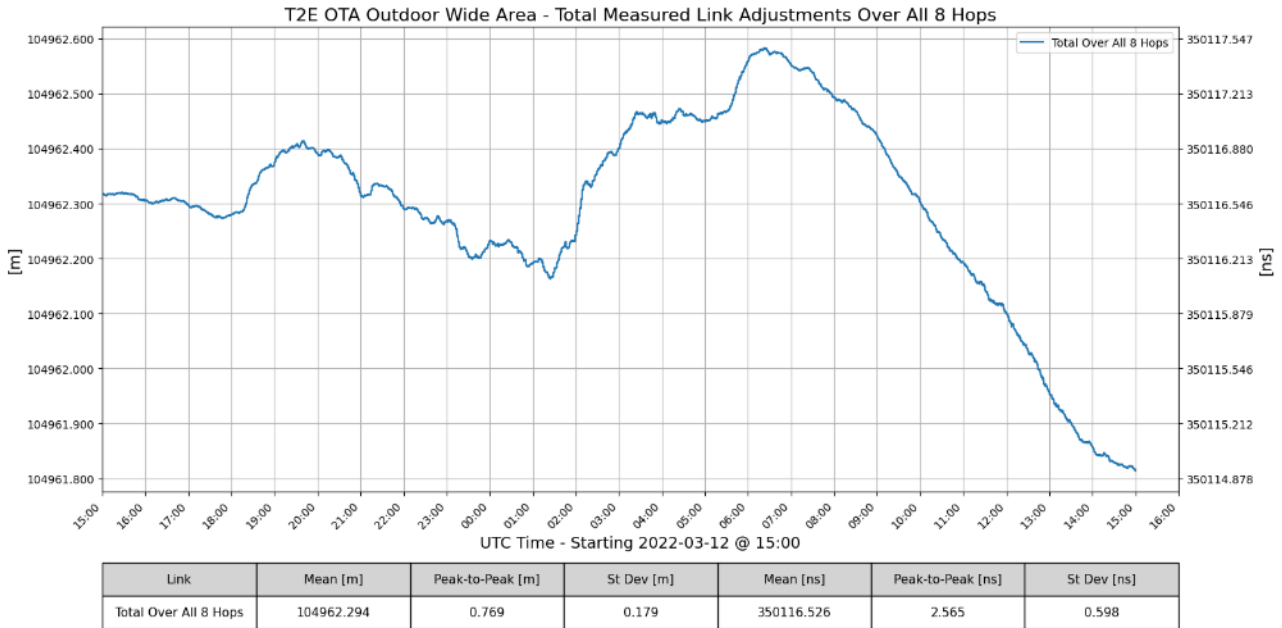

Figure 6-32: T2E Total Measured Link Adjustments Over All 8 Hops

6.1.7 T2F – OTA Outdoor to Indoor

6.1.7.1 Locata Internal Time Transfer

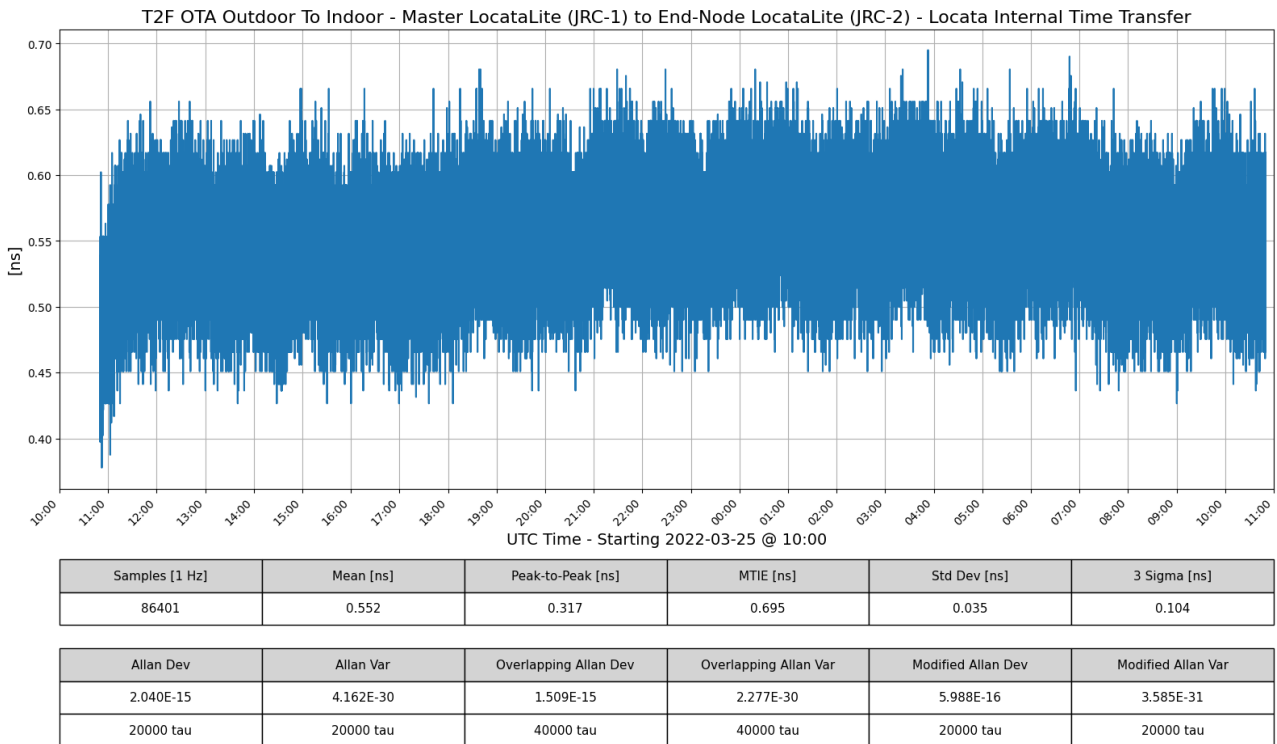

Figure 6-33: T2F Locata Internal Time Transfer Time Series Plot

6.1.7.2 Locata External Time Synchronization

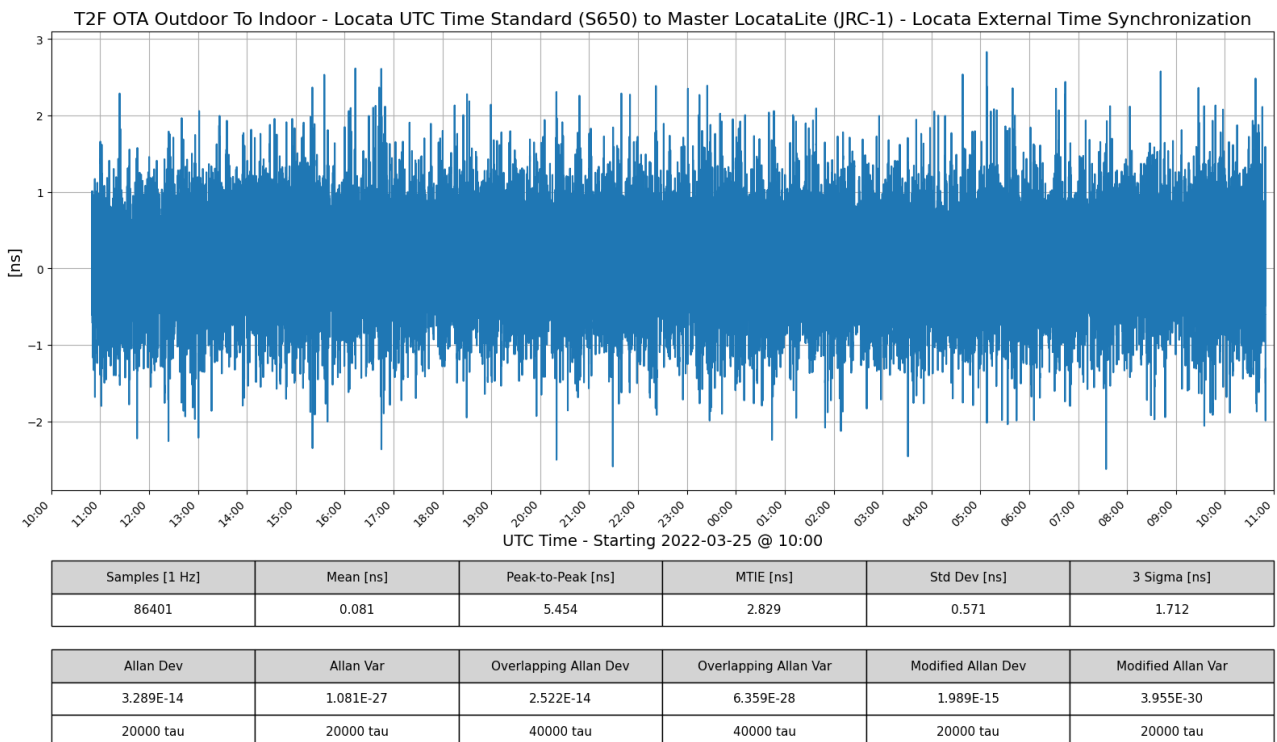

Figure 6-34: T2F Locata External Time Synchronization Time Series Plot

6.1.7.3 Locata External Time Transfer

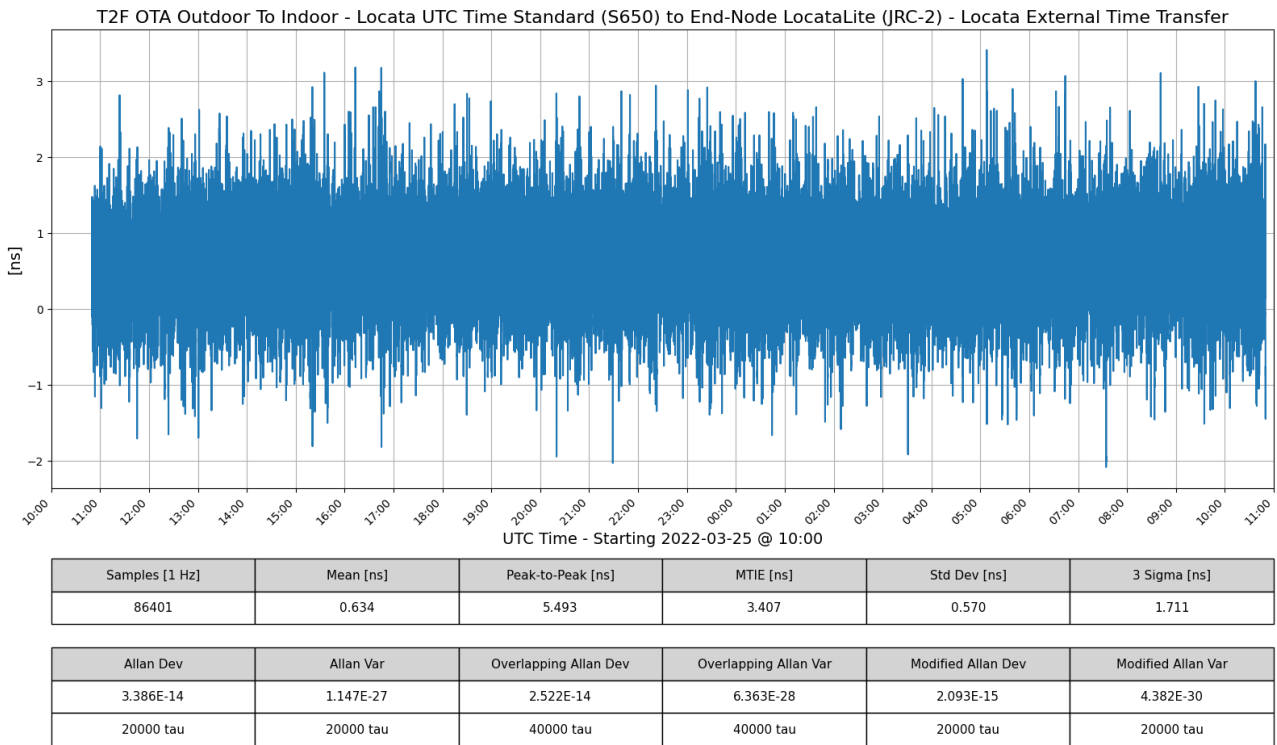

Figure 6-35: T2F Locata External Time Transfer Time Series Plot

6.1.7.4 Locata to UTC Comparison & Clock Comparison

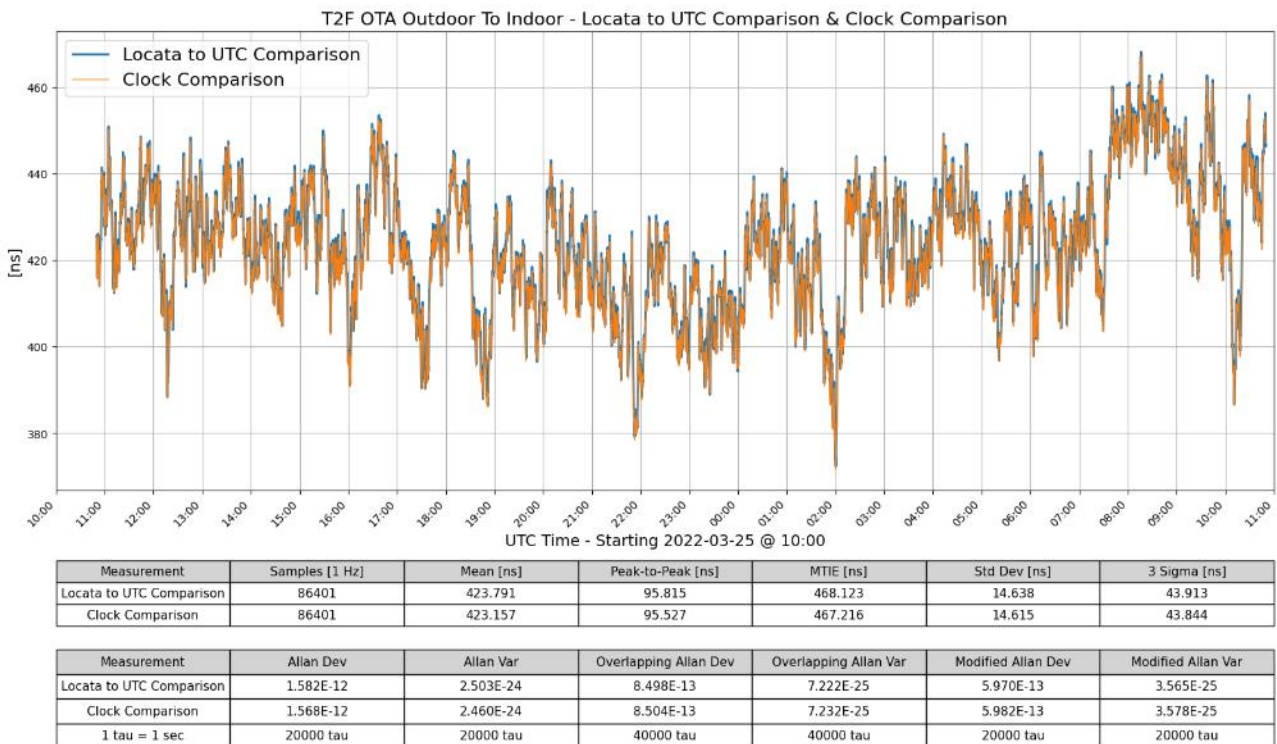

Figure 6-36: T2F Locata to UTC Comparison & Clock Comparison Time Series Plot

6.1.7.5 Measured Link Adjustments

The measured link adjustments show a variation of 129 ps (39 mm) over the 24 hour test period. The observed adjustments are a combination of tropospheric effects over-the-air and the thermal variations on the total length of 57 m of coax cable connecting the antennas to the LocataLites.

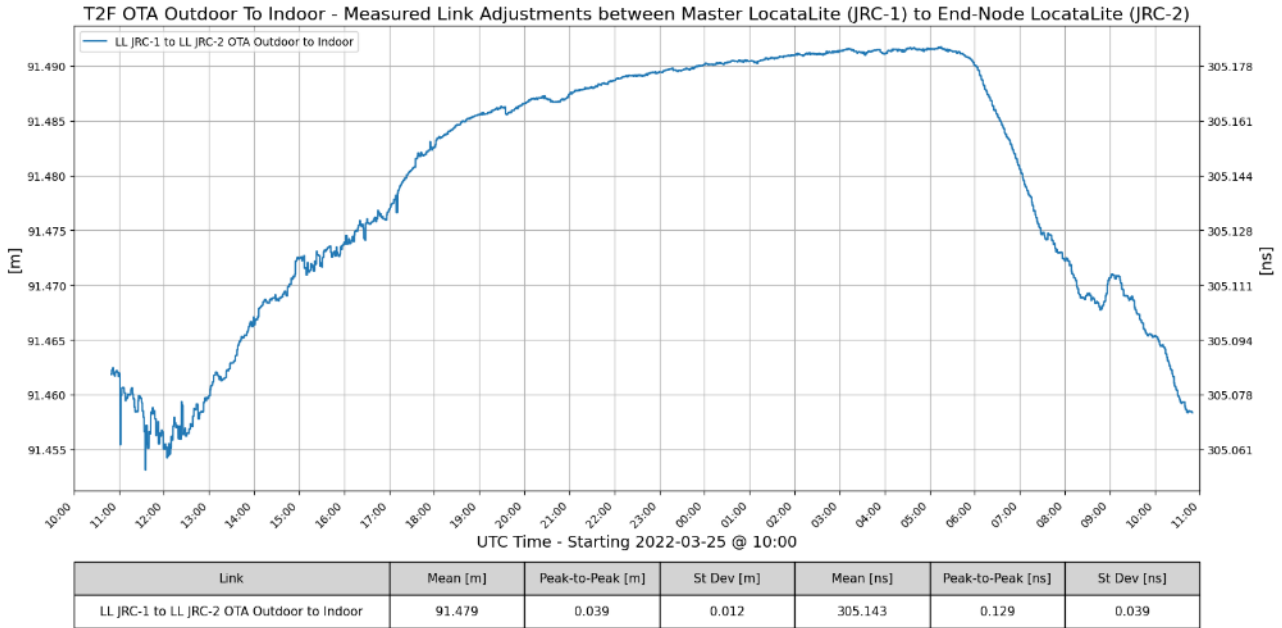

Figure 6-37: T2F Measured Link Adjustments

6.1.8 T2G – Time Transfer to a Mobile Rover

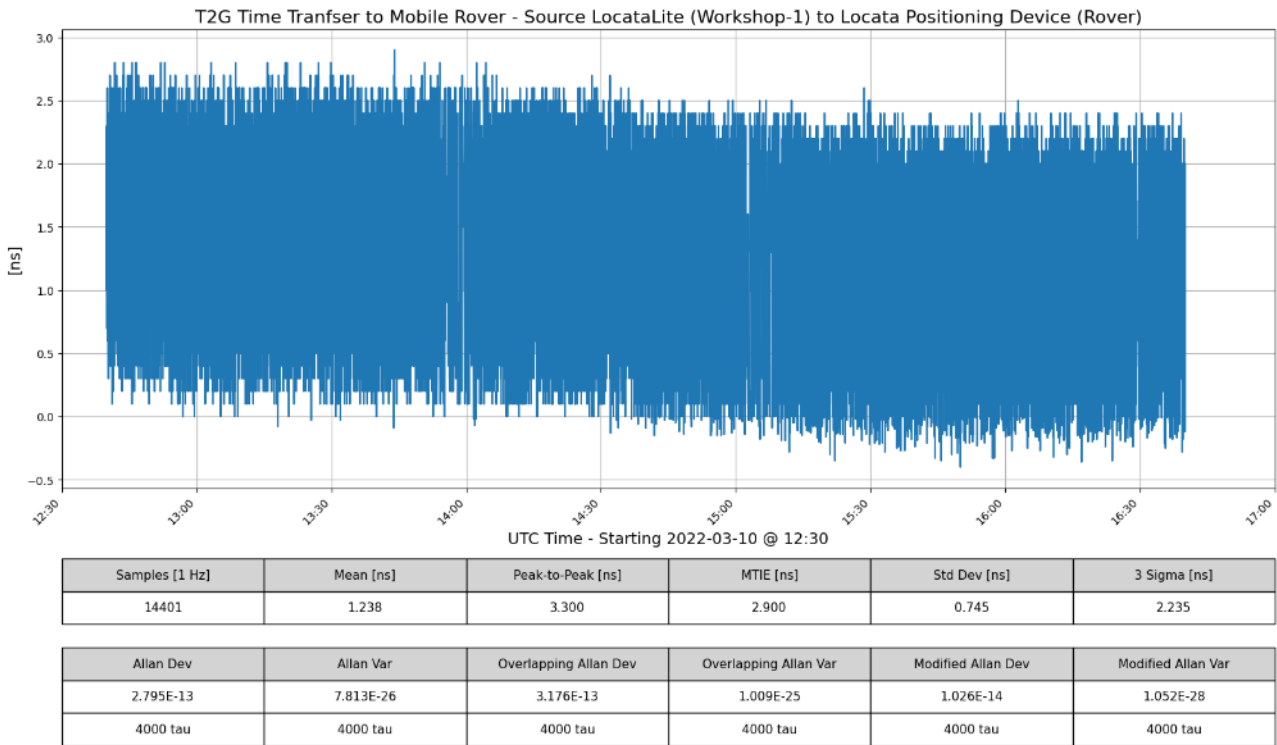

Figure 6-38: T2G Time Transfer to a Mobile Rover Time Series Plot

6.1.9 Allan Deviation Plots

6.1.9.1 Locata Internal Time Transfer

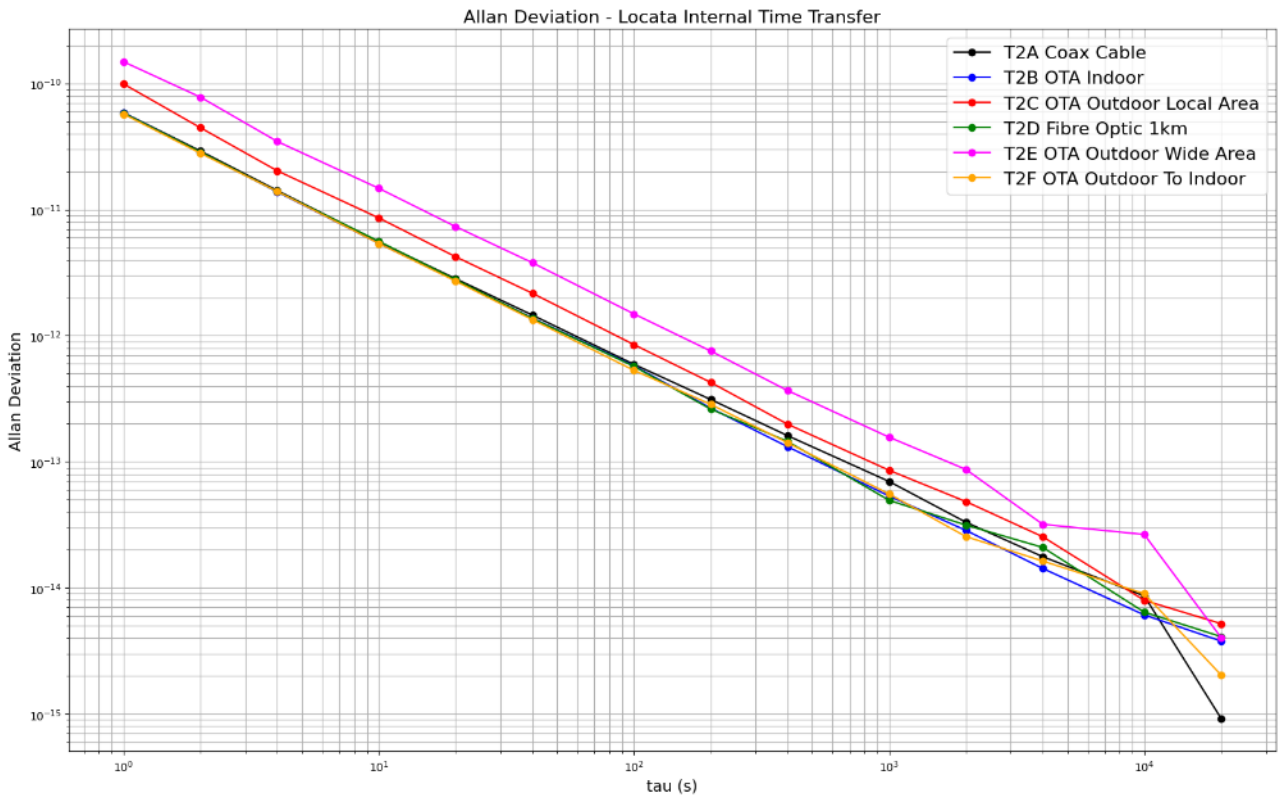

Figure 6-39: Locata Internal Time Transfer Allan Deviation

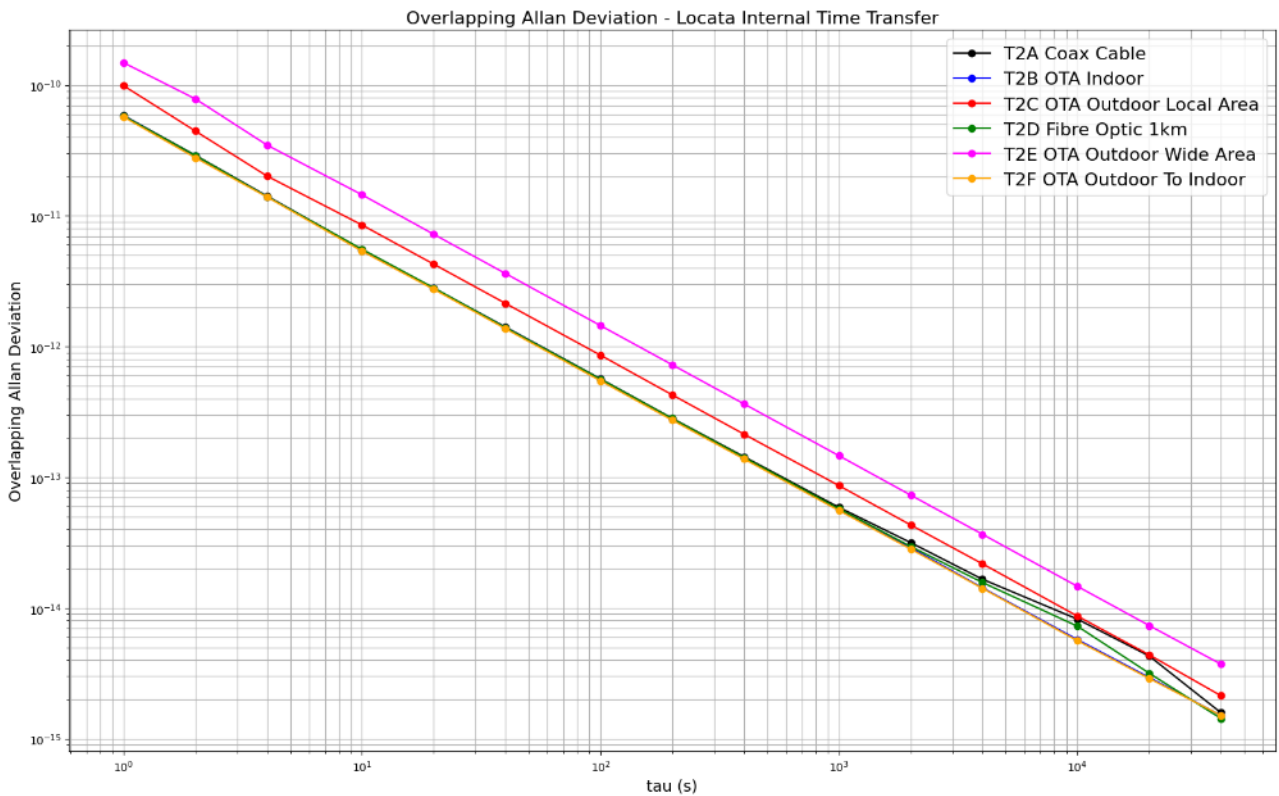

Figure 6-40: Locata Internal Time Transfer Overlapping Allan Deviation

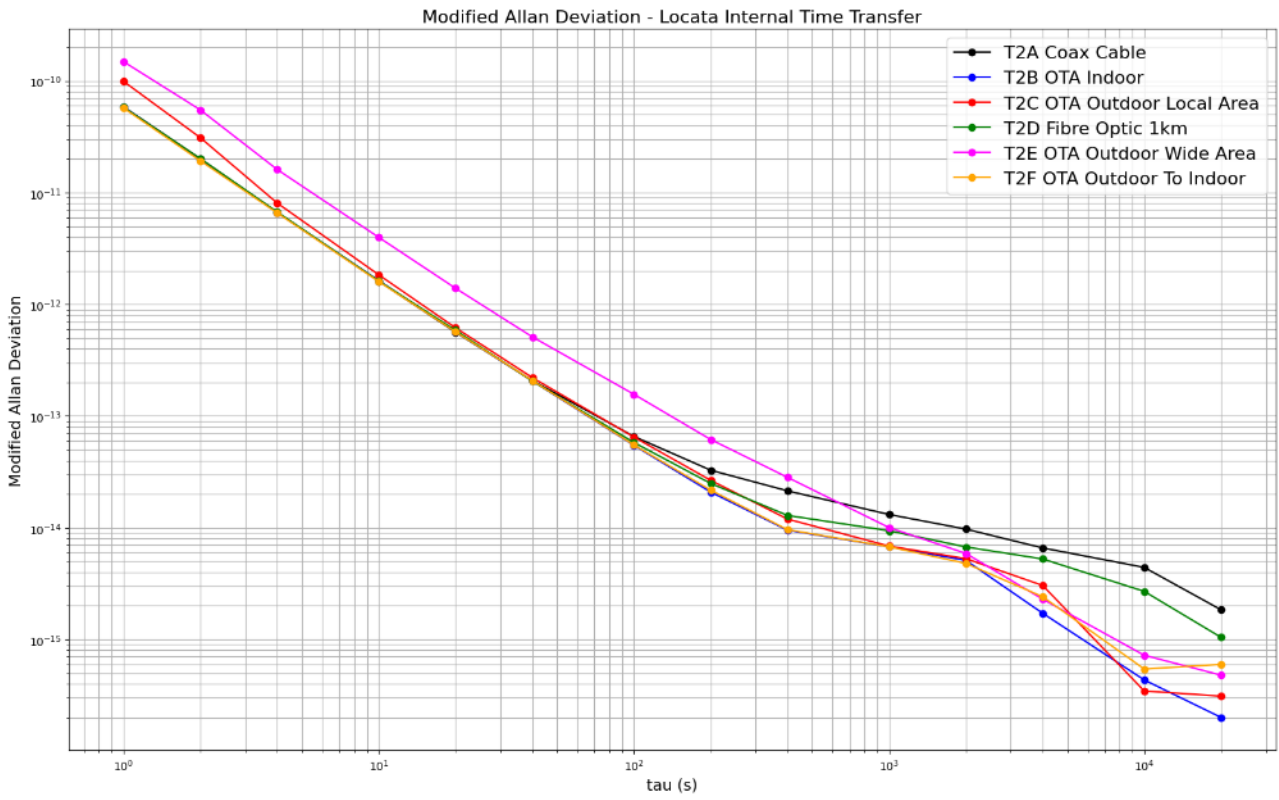

Figure 6-41: Locata Internal Time Transfer Modified Allan Deviation

6.1.9.2 Locata External Time Synchronization

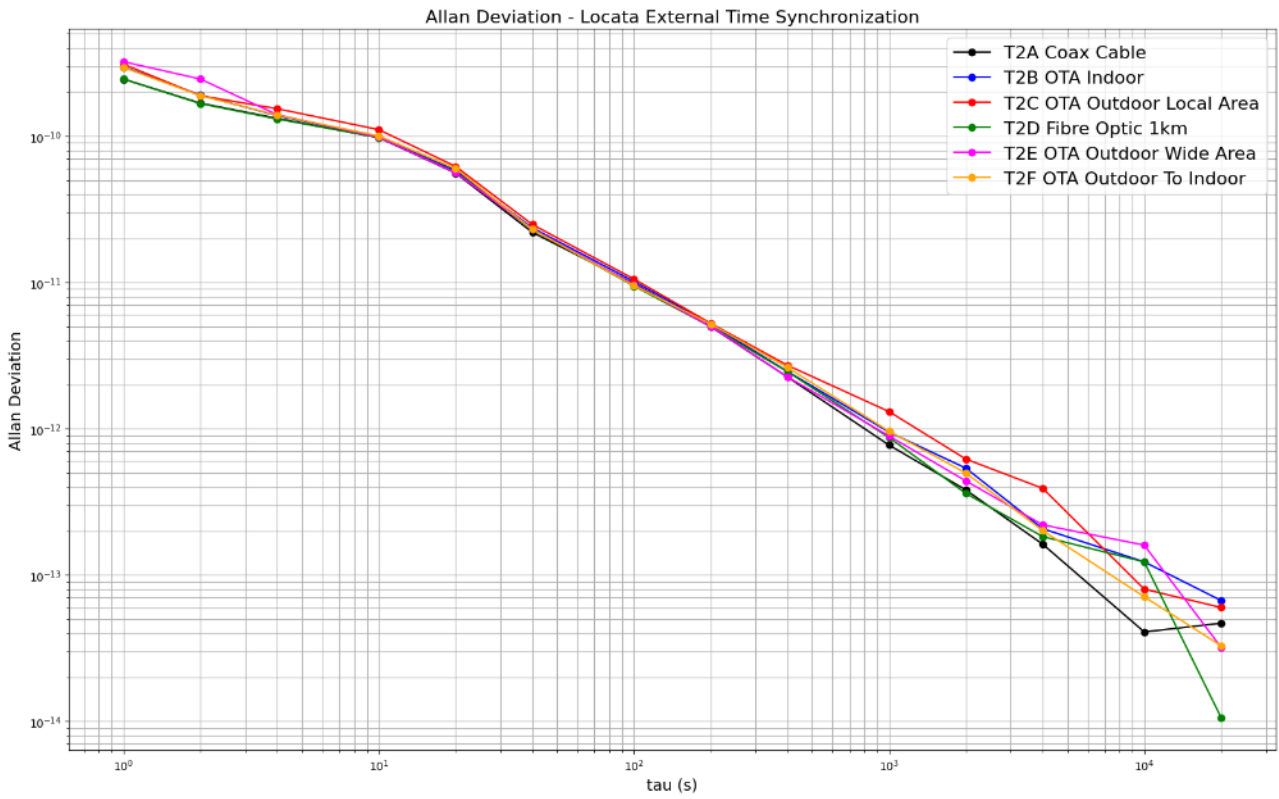

Figure 6-42: Locata External Time Synchronization Allan Deviation

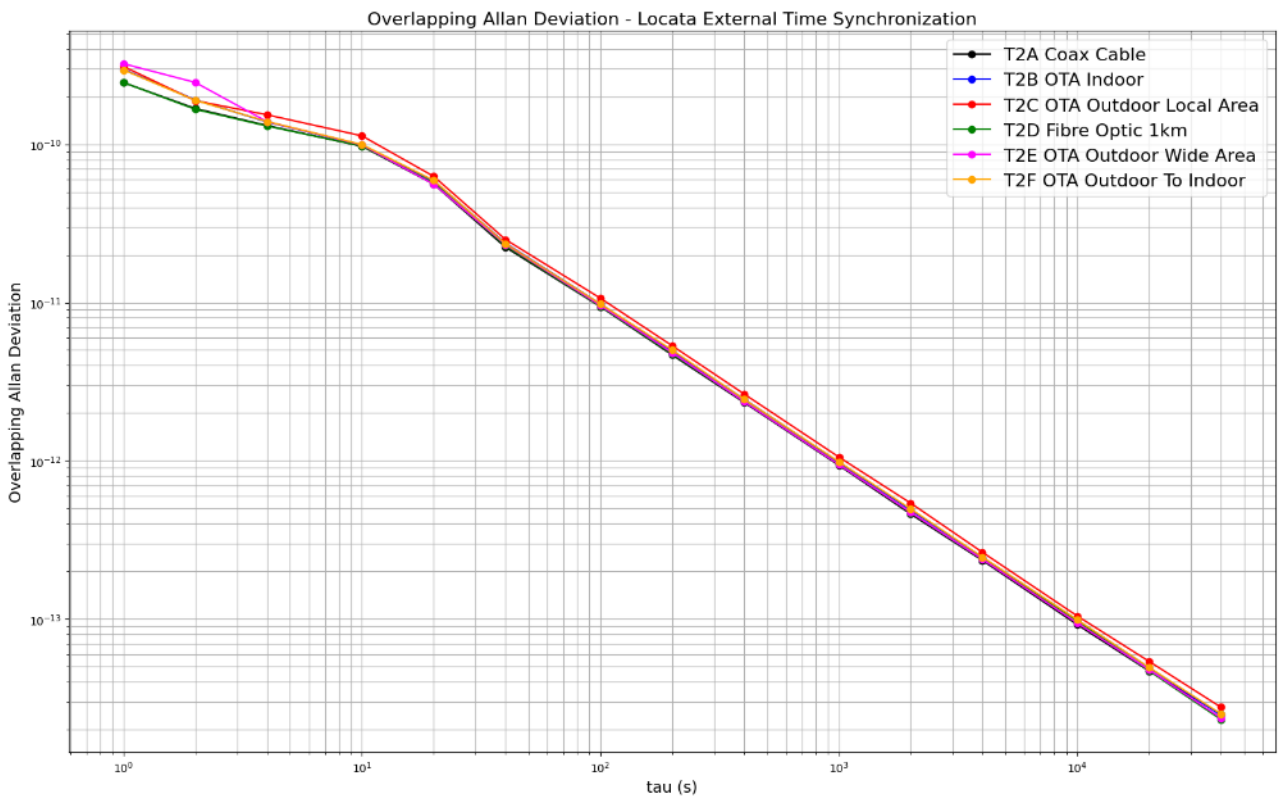

Figure 6-43: Locata External Time Synchronization Overlapping Allan Deviation

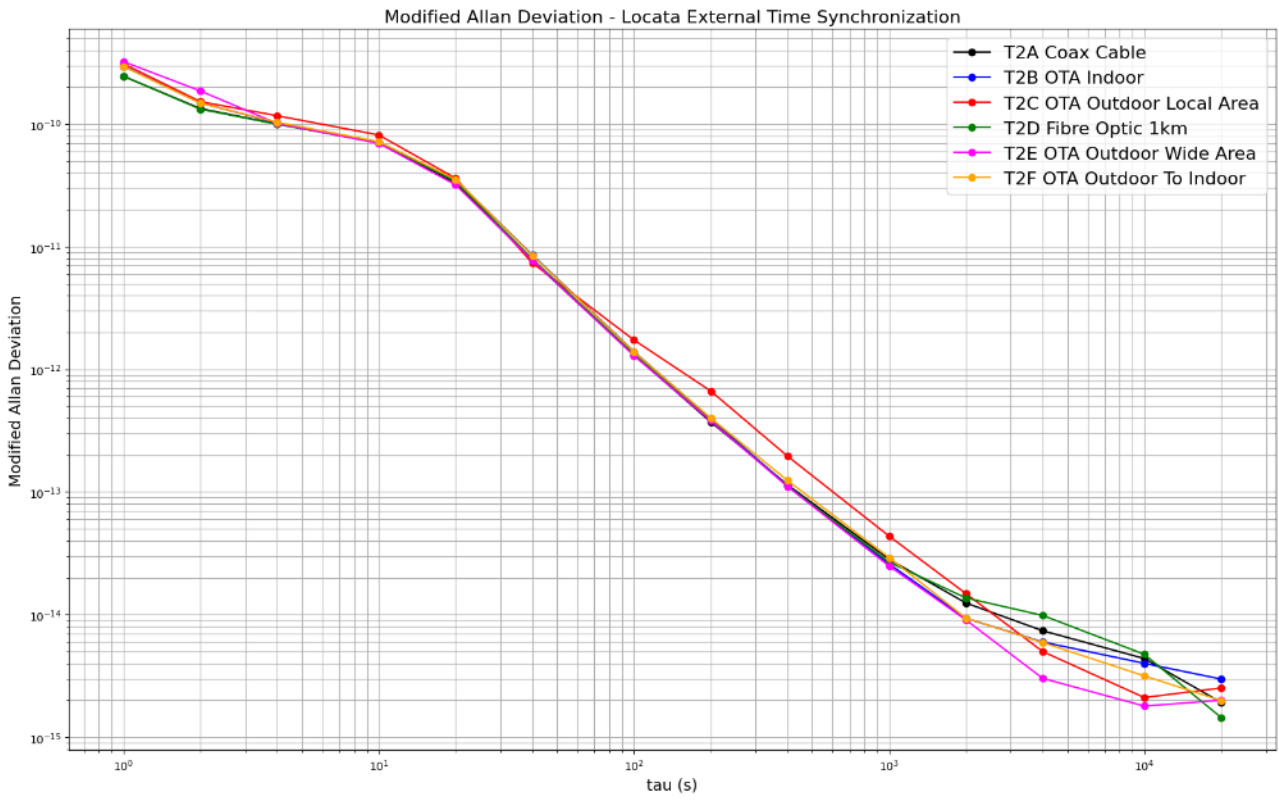

Figure 6-44: Locata External Time Synchronization Modified Allan Deviation

6.1.9.3 Locata External Time Transfer

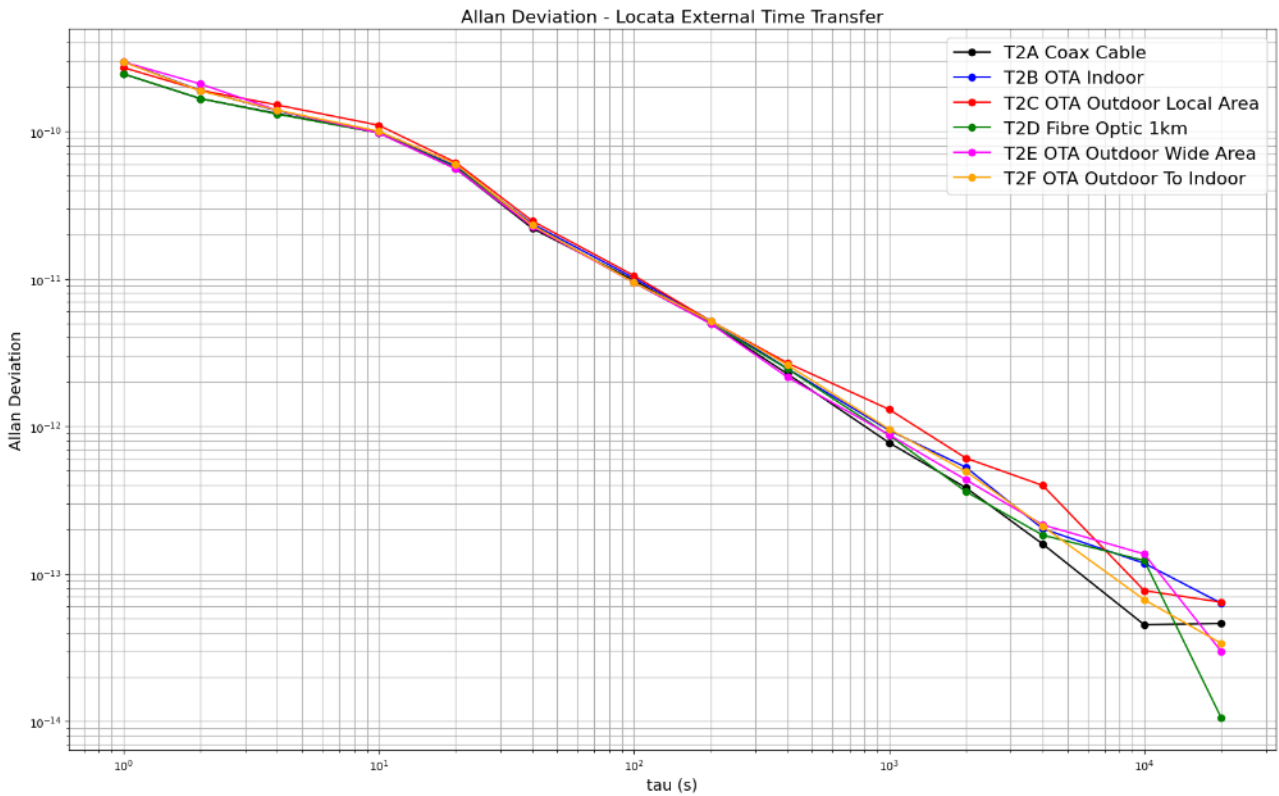

Figure 6-45: Locata External Time Transfer Allan Deviation

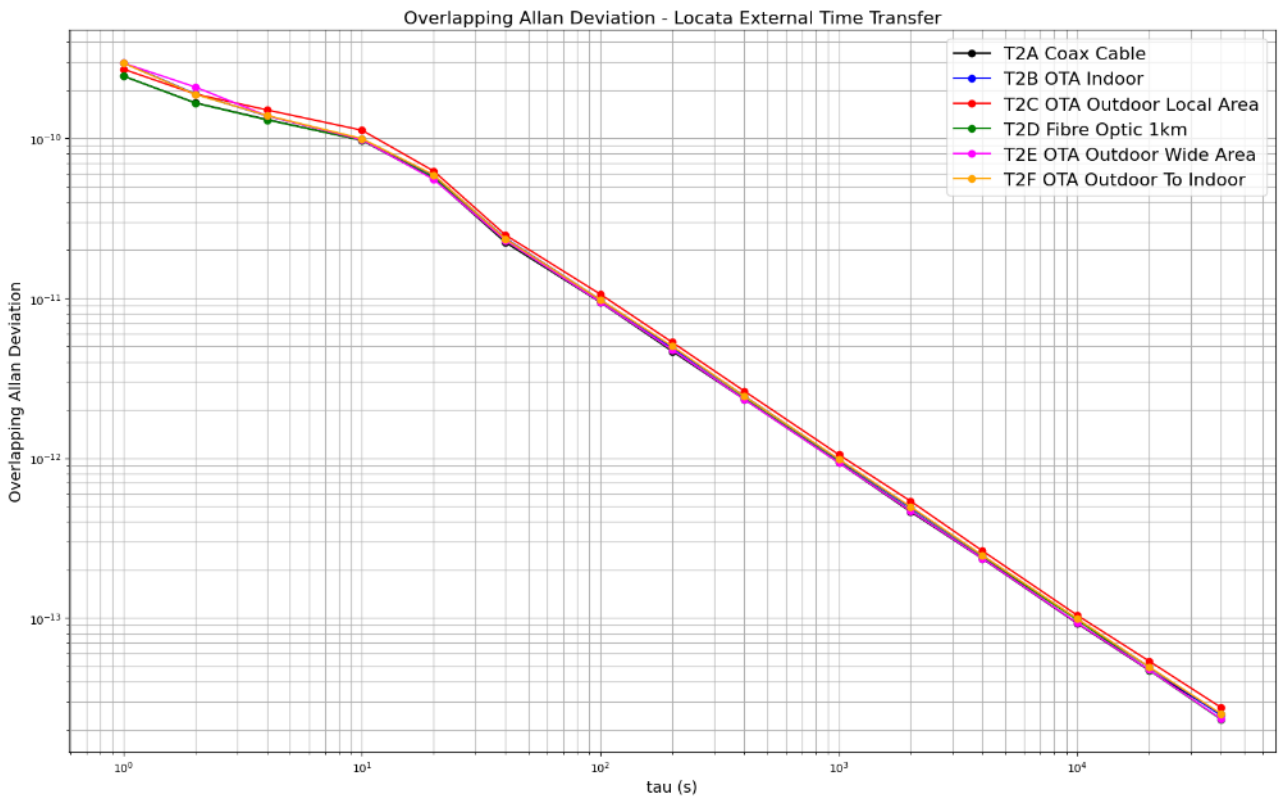

Figure 6-46: Locata External Time Transfer Overlapping Allan Deviation

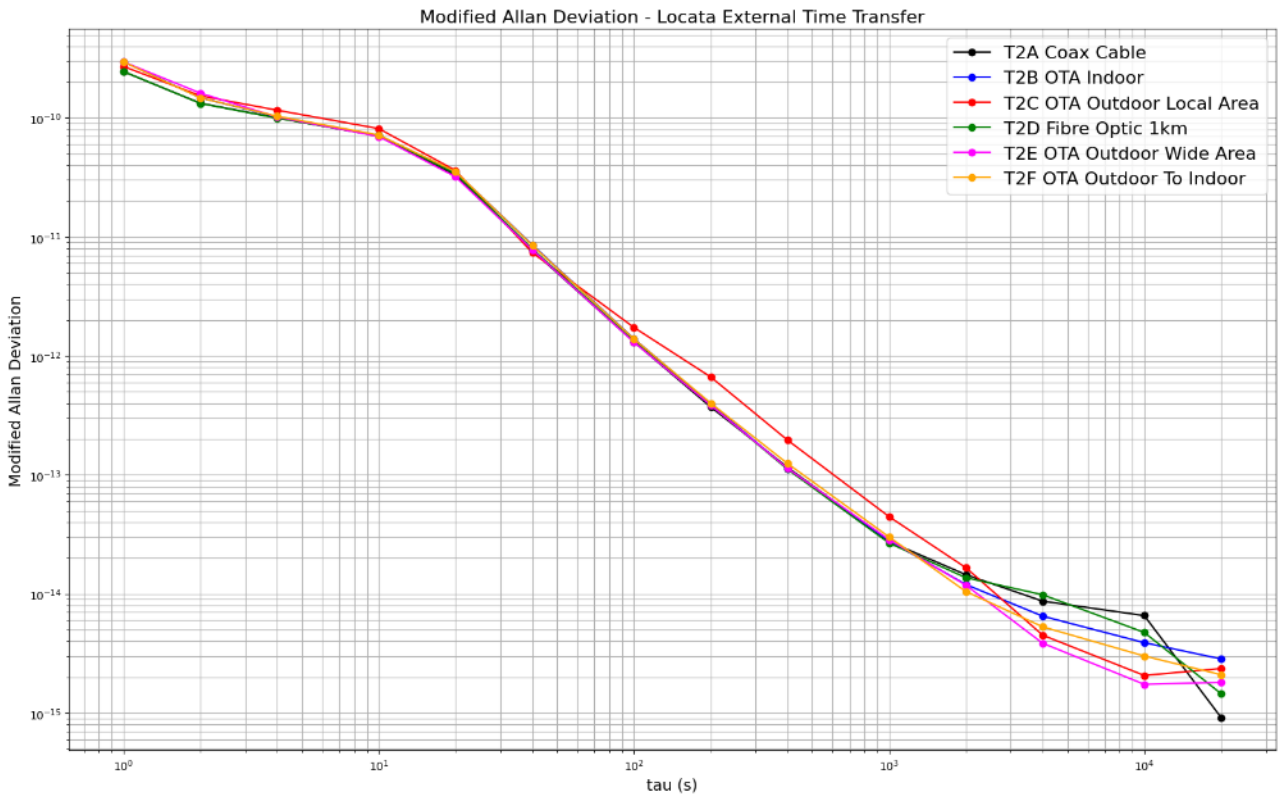

Figure 6-47: Locata External Time Transfer Modified Allan Deviation

6.1.9.4 Locata to UTC Comparison

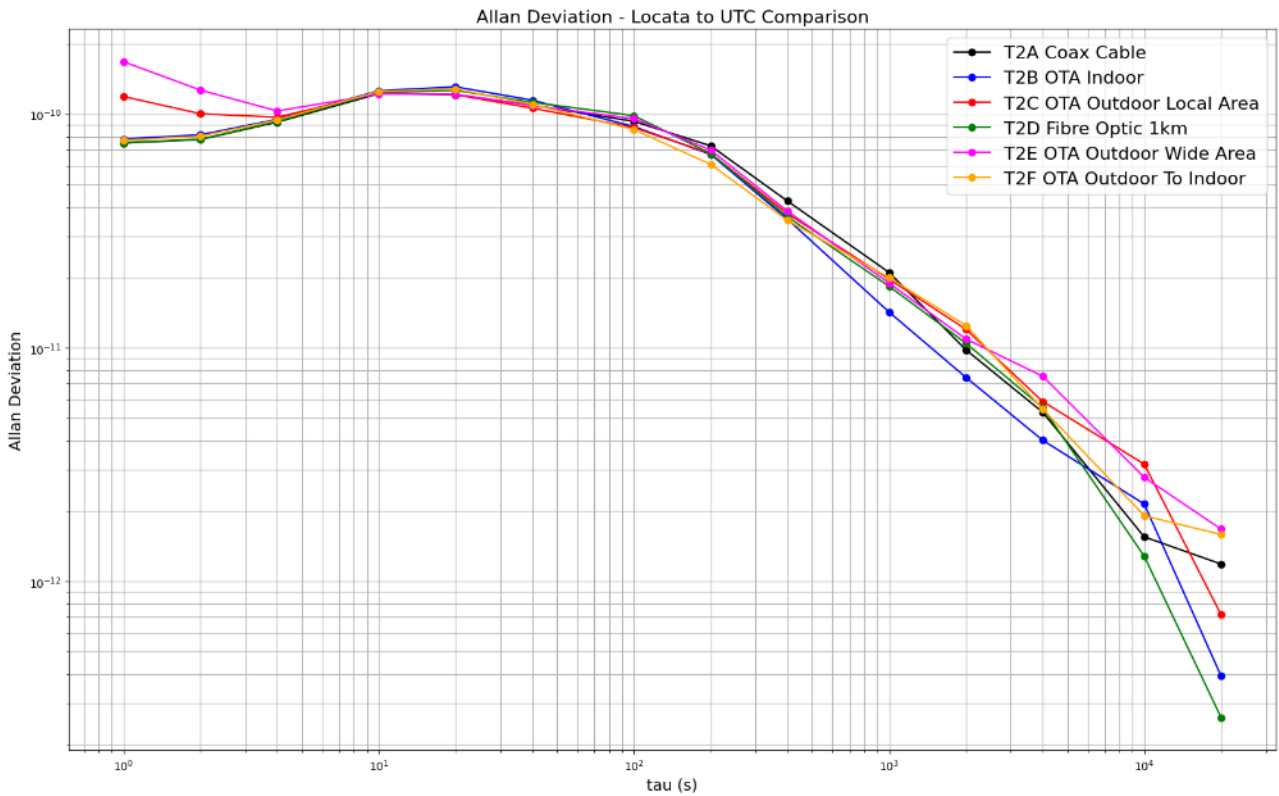

Figure 6-48: Locata to UTC Comparison Allan Deviation

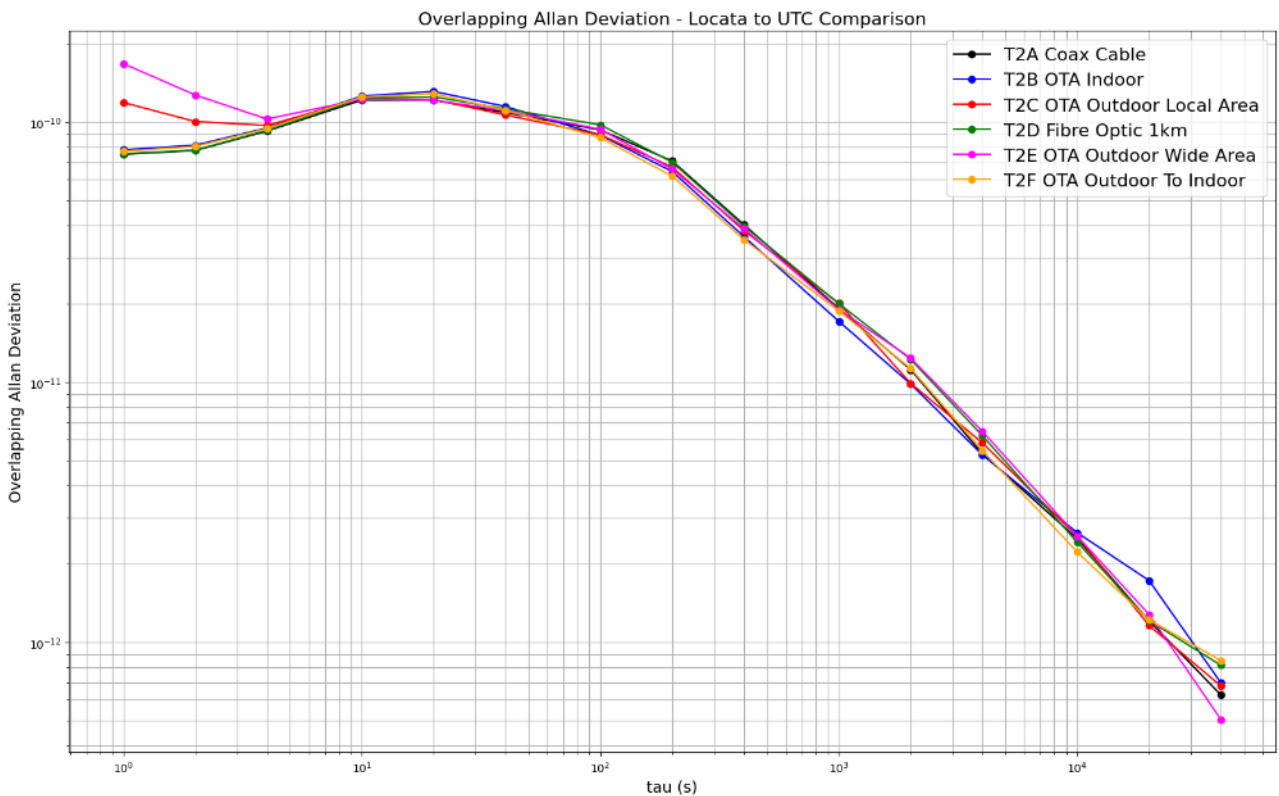

Figure 6-49: Locata to UTC Comparison Overlapping Allan Deviation

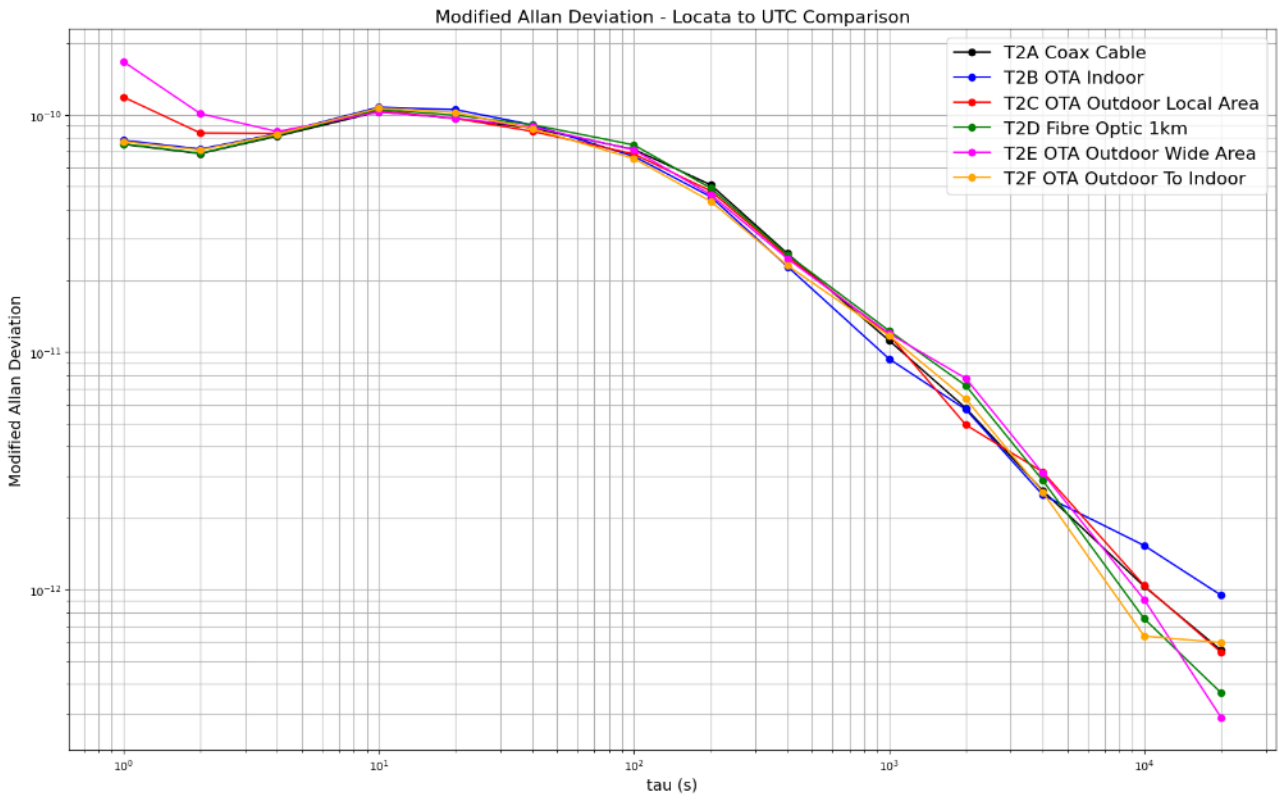

Figure 6-50: Locata to UTC Comparison Modified Allan Deviation

6.1.9.5 Clock Comparison

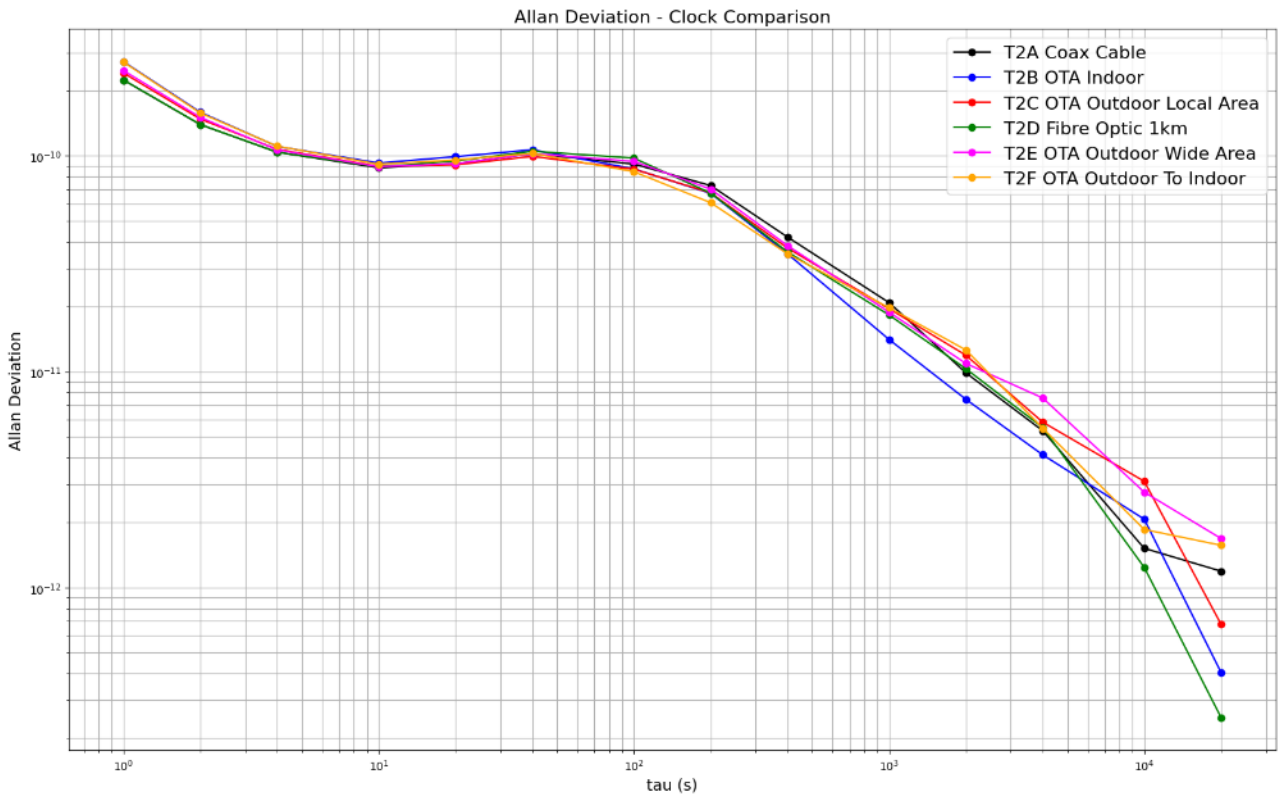

Figure 6-51: Clock Comparison Allan Deviation

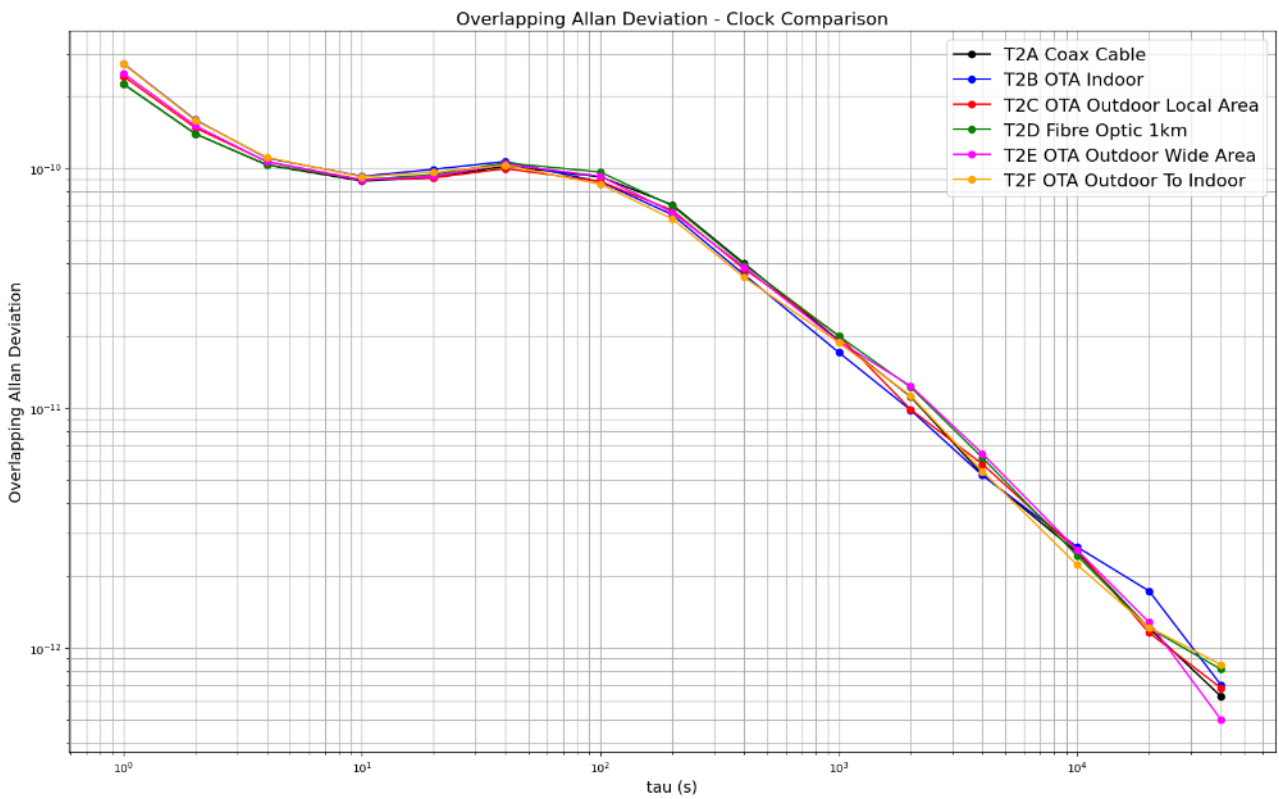

Figure 6-52: Clock Comparison Overlapping Allan Deviation

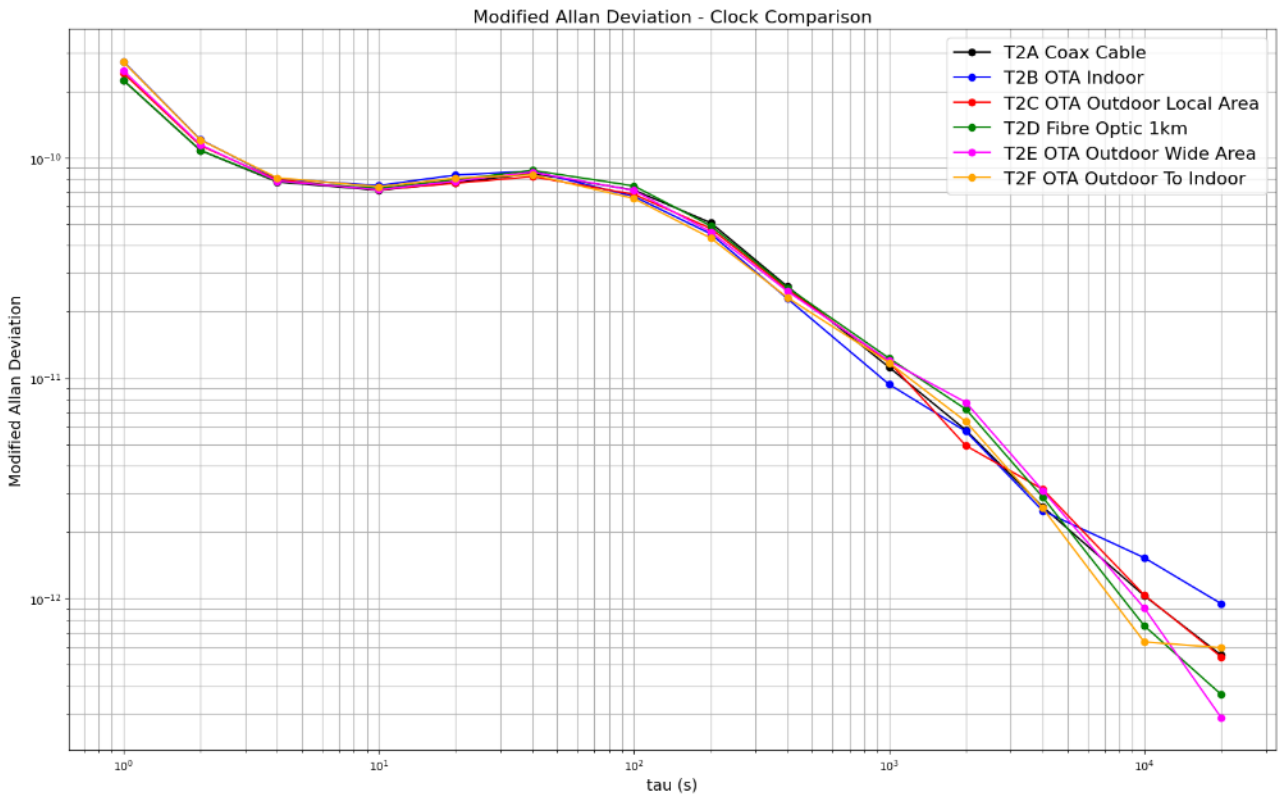

Figure 6-53: Clock Comparison Modified Allan Deviation

6.1.9.6 Time Transfer to Mobile Rover

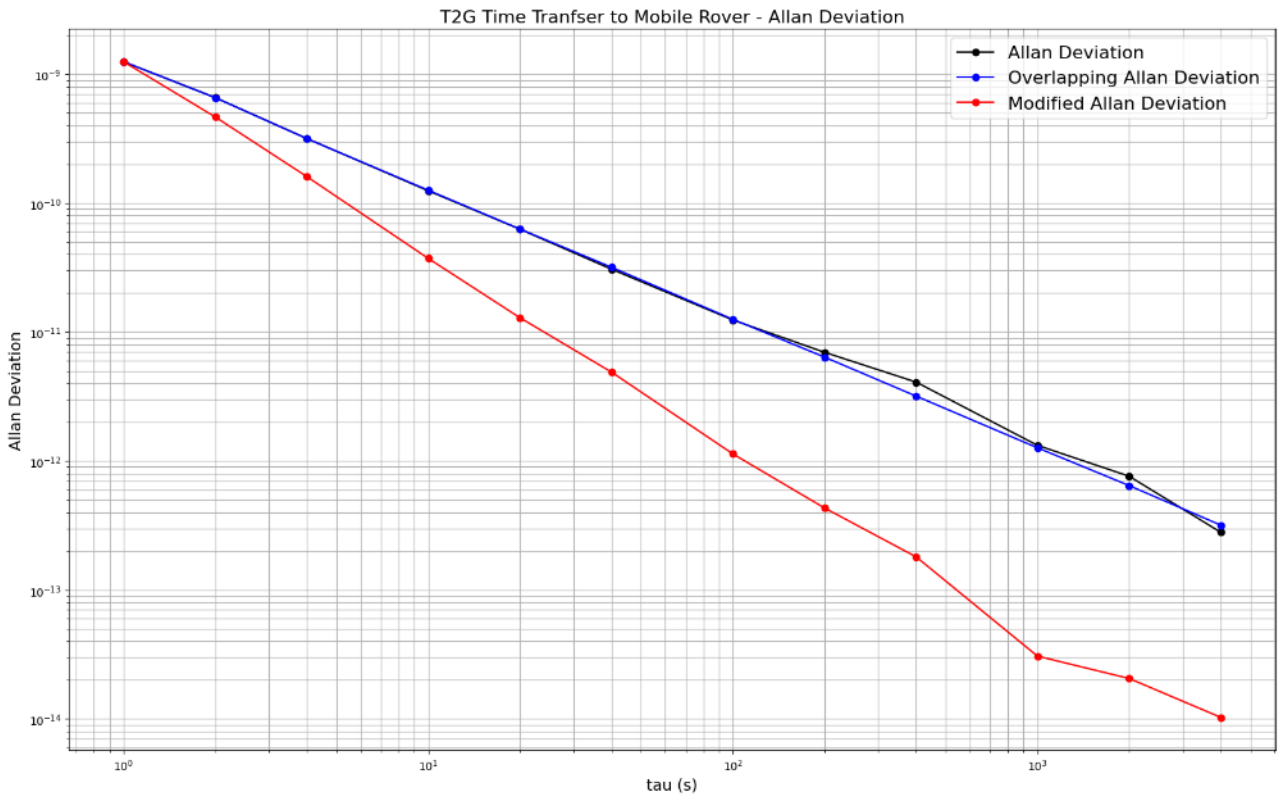

Figure 6-54: Time Transfer to Mobile Rover Allan Deviations

6.1.10 Time of Day Messages

Time of Day (ToD) messages were logged with sub-second resolution, using SW timestamps via a QGIS desktop application. The QGIS application was running on a laptop using the Windows 10 operating system. The messages were received over serial cables via Serial to USB converters.

The following is an example of the ToD log files from test T2A Coax Cable:

S650 (s650_zda1_12.txt)
02:21:02.110000,\$GPZDA,152102,22,03,2022,00,00*4C
02:21:03.120000,\$GPZDA,152103,22,03,2022,00,00*4D
02:21:04.107000,\$GPZDA,152104,22,03,2022,00,00*4A
02:21:05.118000,\$GPZDA,152105,22,03,2022,00,00*4B
02:21:06.123000,\$GPZDA,152106,22,03,2022,00,00*48
...

JRC-1 (JRC-1_zda2_12.txt)
02:21:02.122000,\$GPZDA,152102.00,22,3,2022,,*52
02:21:03.119000,\$GPZDA,152103.00,22,3,2022,,*53
02:21:04.118000,\$GPZDA,152104.00,22,3,2022,,*54
02:21:05.108000,\$GPZDA,152105.00,22,3,2022,,*55
02:21:06.117000,\$GPZDA,152106.00,22,3,2022,,*56
...

JRC-2 (JRC-2_zda3_12.txt)
02:21:02.120000,\$GPZDA,152102.00,22,3,2022,,*52
02:21:03.108000,\$GPZDA,152103.00,22,3,2022,,*53
02:21:04.117000,\$GPZDA,152104.00,22,3,2022,,*54
02:21:05.123000,\$GPZDA,152105.00,22,3,2022,,*55
02:21:06.110000,\$GPZDA,152106.00,22,3,2022,,*56
...

The timestamp of message reception preceding each \$GPZDA message was used to align ZDA messages from the different sources. The time components of the ZDA messages were then compared to confirm that the different sources were reporting the same UTC time. For this reason, any occasional small spikes in the timestamps are inconsequential to the ToD performance measurement and are due to the serial port data being processed by the application running on the laptop.

Synchronization of the serial ZDA ToD messages from LocataLites JRC-1 and JRC-2 were verified against the Locata UTC Time Standard (S650) using a python script as described in Section 3.5 Measurement Data Processing.

Despite the sub-second resolution on the timestamps, the differences in the timestamp of message reception between any two of the serial streams are susceptible to spurious delays. This is because the application logging the messages is running on a non-real-time system with many other processes. The percentage of spurious delays (greater than 0.05 seconds) is summarized in the table below.

Test	Percentage of Spurious Delays in ToD Message Reception
T2A Coax Cable	0.001
T2B OTA Indoor	0.009
T2C OTA Outdoor Local Area	-
T2D Fibre Optic 1km	0.000
T2E OTA Outdoor Wide Area	0.001
T2F OTA Outdoor to Indoor	0.006
T2G Time Transfer to Mobile Rover	-

Table 6-15: Percentage of Spurious Delays in Time-of-Day Message Reception

There were no issues identified in the synchronization of ToD messages logged from the Locata UTC Time Standard (S650) and LocataLites JRC-1 and JRC-2.

The following are plots of the timestamp differences for each test in which ToD messages were logged. Note the differences are well below +/- 0.1 seconds except for intermittent spikes that are due to the fact that the serial messages are timestamped using a non-real time system.

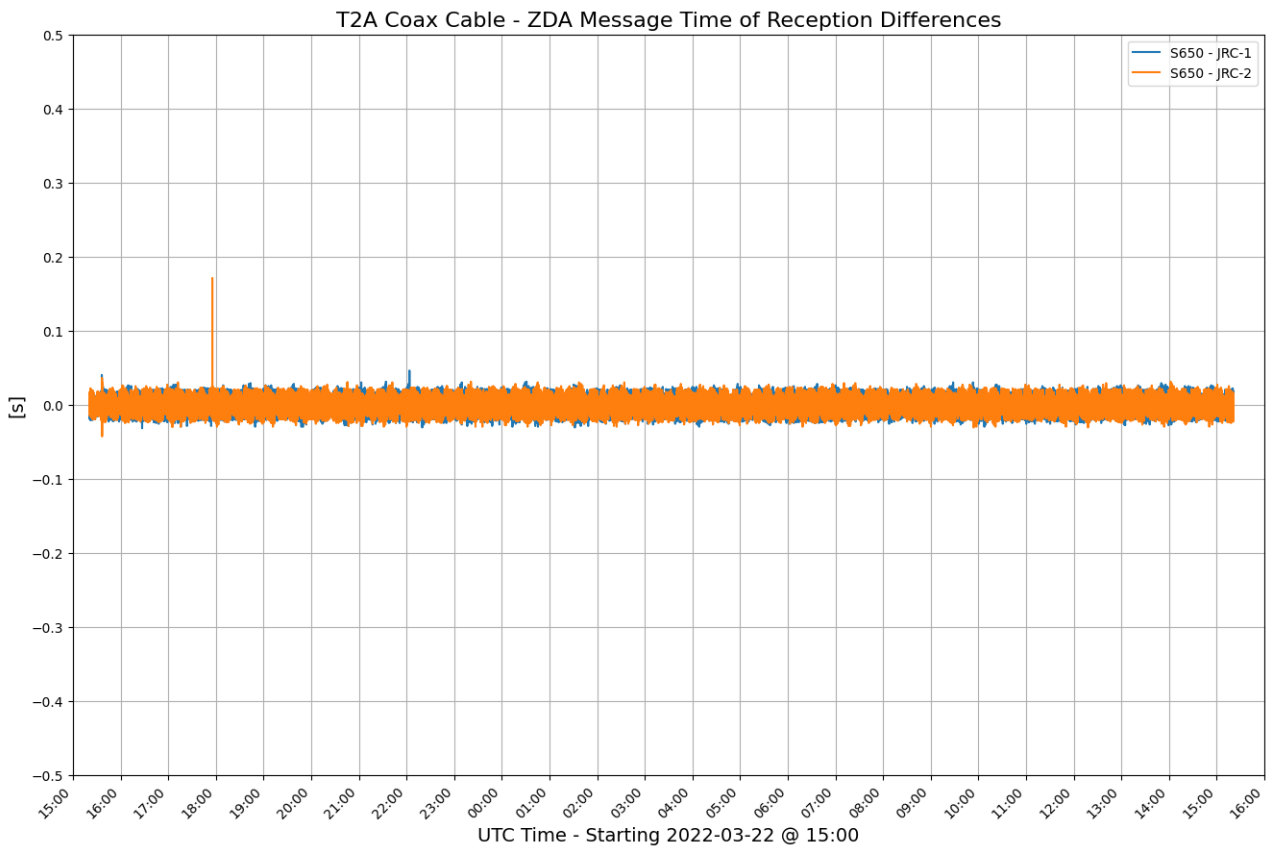

Figure 6-55: T2A ZDA Message Time of Reception Differences

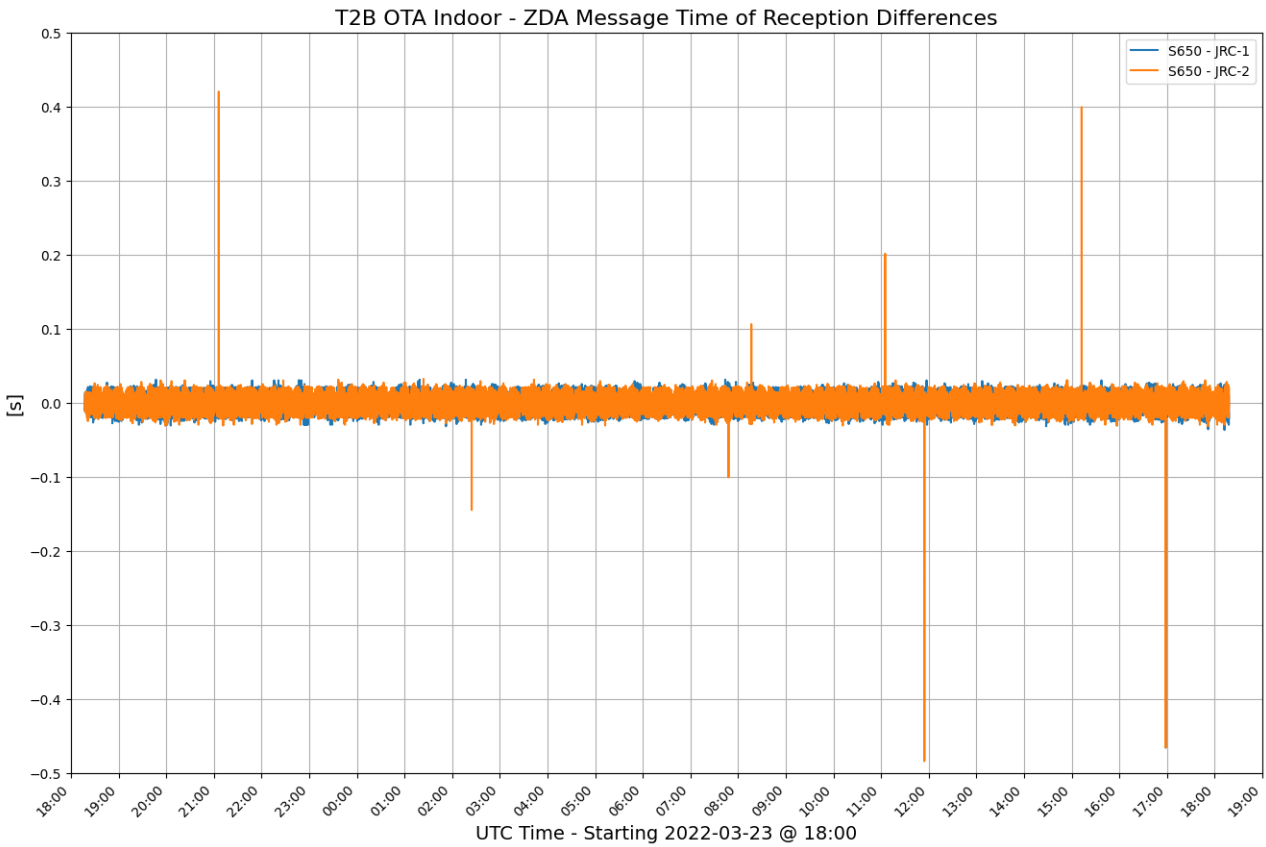

Figure 6-56: T2B ZDA Message Time of Reception Differences

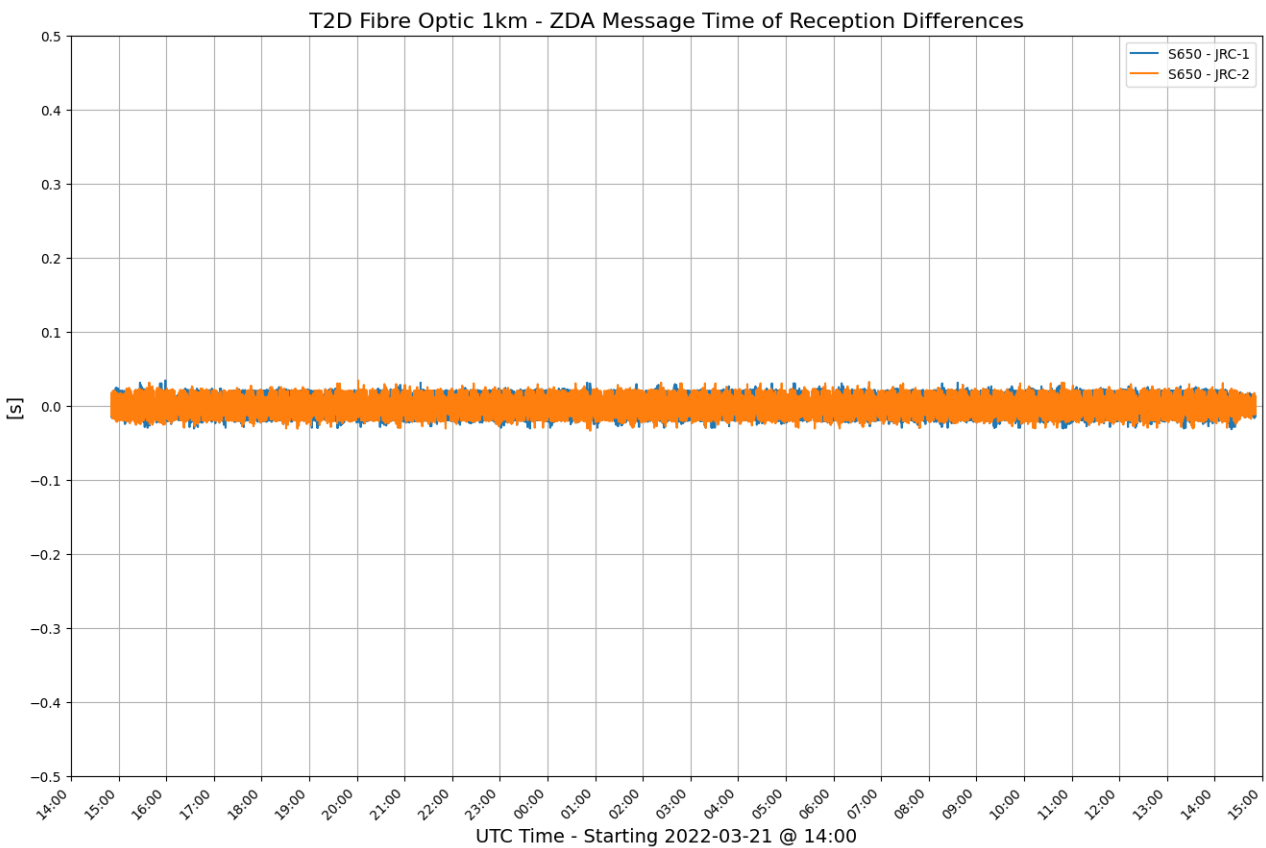

Figure 6-57: T2D ZDA Message Time of Reception Differences

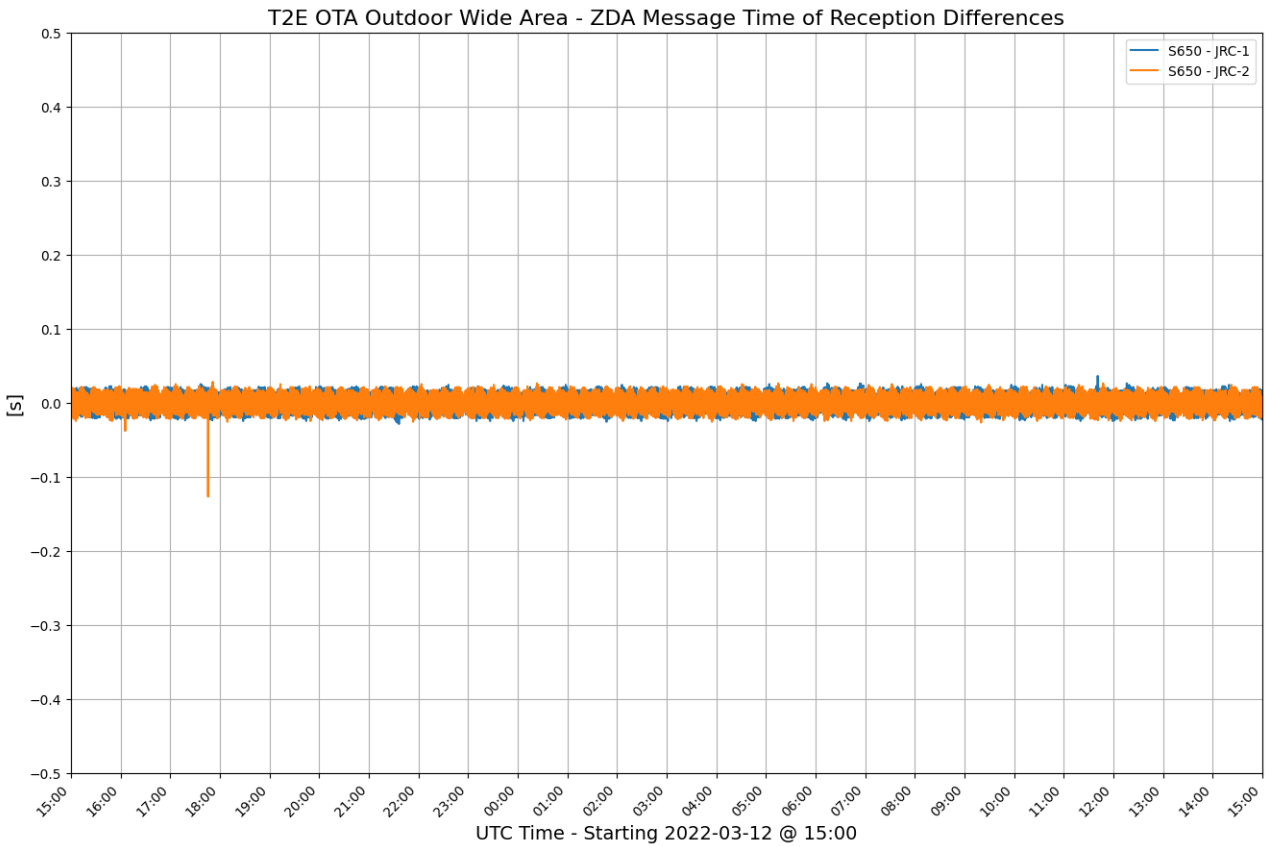

Figure 6-58: T2E ZDA Message Time of Reception Differences

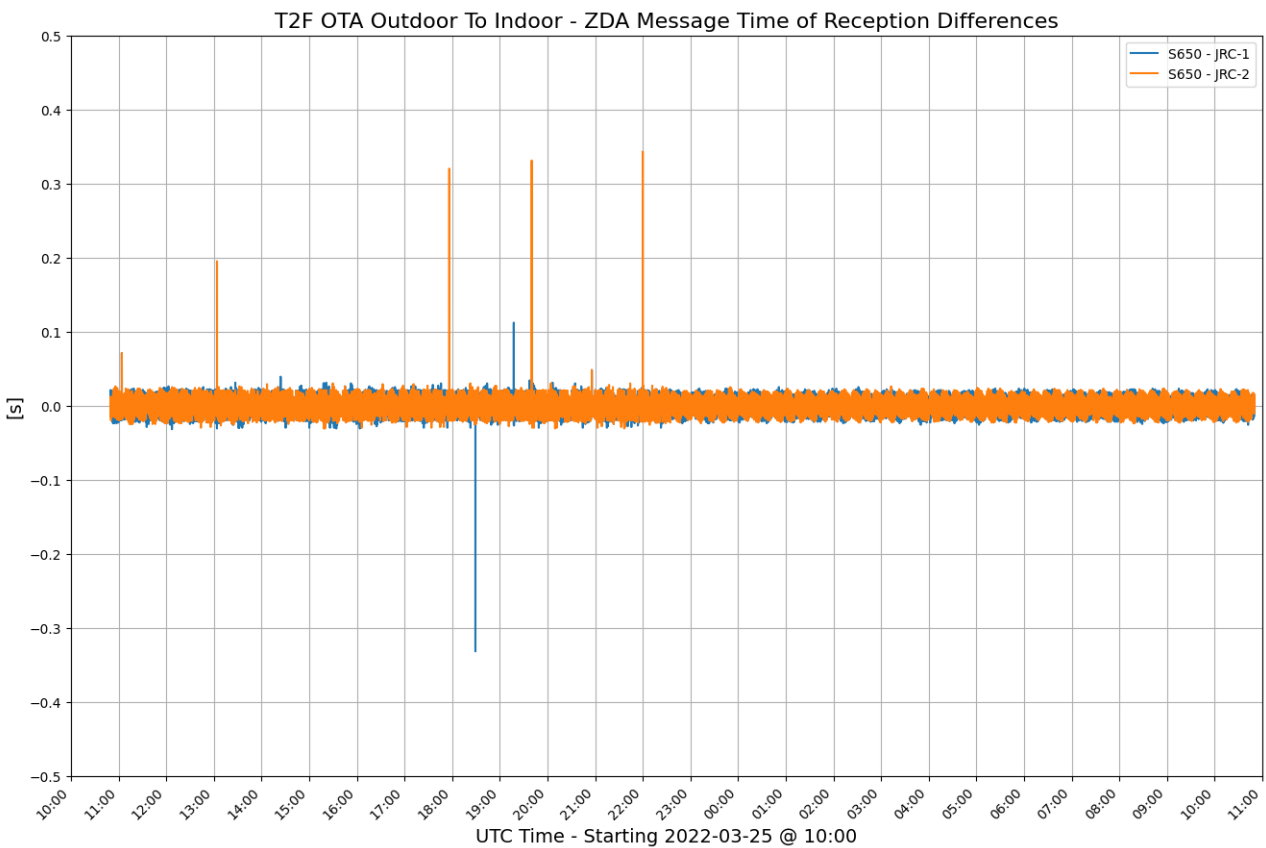

Figure 6-59: T2F ZDA Message Time of Reception Differences

6.2 Positioning Performance

6.2.1 Positioning Performance Summary

The average Locata outdoor positioning performance was 11 mm static and 10 mm kinematic with 4 mm and 5 mm standard deviation respectively.

The average Locata indoor position performance was 8 mm static and 5 mm kinematic with 5 mm and 4 mm standard deviation respectively.

Table 6-16 shows Locata average positioning performance across all positioning tests.

Test	Reference	Number of Points			2D Mean Difference (m)	2D Standard Deviation (m)	2D RMSE (m)
		Total Station	GNSS	Locata			
T6A Outdoor static	Total Station	58	NA	3846	0.011	0.004	0.012
T6B Outdoor kinematic	GNSS (2D difference)	NA	48701	48701	0.010	0.005	0.011
T7A Indoor static	Total Station	14	NA	9423	0.008	0.004	0.009
T7B Indoor kinematic	Total Station (cross-track)	269	NA	269	0.005	0.004	0.006

Table 6-16: Locata Positioning Performance Summary

6.2.1.1 Locata Alternative PNT Positioning Performance Levels

The table below shows Locata alternative PNT positioning performance levels.

The 1 day horizontal accuracy value comprises the weighted average from both indoor and outdoor 2D positioning tests (T6 and T7). A projected value for vertical accuracy is provided since 3D positioning was not demonstrated due to constraints on mounting transmit antennas at height in Building 48 (Workshop).

Values for 14 days and 100 days are provided from an existing deployment at a Locata customer site.

Locata Positioning Performance Parameters	Number of Days after GNSS Outage		
	< 1 day Demonstrated @ JRC	14 days Deployed @ Customer Site	100 days Deployed @ Customer Site
Horizontal Accuracy (95 % meters)	0.018m @ HDOP 0.9	0.037 m	0.037 m
Vertical Accuracy (95 % meters) <i>(projected)</i>	0.025m @ VDOP 1.0	0.050 m	0.050 m
Availability (%)	100	99.9999	99.9999
Continuity (per hour)	1	$1 - 1 \times 10^{-8}$	$1 - 1 \times 10^{-8}$
Integrity (per hour)	1	$1 - 1 \times 10^{-7}$	$1 - 1 \times 10^{-7}$
Time To Alert (seconds)	0.2 seconds		
First time to provide services upon cold start	150 seconds		

Table 6-17: Locata Alternative PNT Positioning Performance Levels

6.2.2 Indoor Positioning

Both static and kinematic positioning were evaluated in a very difficult, multipath-rich indoor environment – the JRC Workshop building has metal-clad walls and a steel roof. A laser Total Station was used as reference for all indoor positioning tests, along with a 360° survey prism located on top of the Locata VRay Orb.

For static comparison a single Total Station point was recorded as reference, as the Locata Rover platform was not moving during each occupation. The Locata Rover position was then compared to these individual Total Station points for each static location.

For kinematic comparison, the asynchronous time base and varying sampling rate of the Total Station prevented a direct comparison to the Locata Rover positions, which were recorded at a 10Hz rate and synchronized to the Locata UTC backbone. In addition to the asynchronous and varying sampling rate of the Total Station, accuracy of the internal time tagging of the Total station is not suitable for synchronizing to a UTC reference.

To overcome these limitations, the cross-track difference of the Locata Rover position trajectory was compared to the auto-tracking Total Station trajectory. The approximate time alignment of the Total Station and Locata Rover was first determined by minimising position differences. Then the normal projected position of the Total Station points to the Locata Rover’s trajectory was calculated to determine the 2D cross-track difference (as illustrated in Figure 6-60). Using the 2D cross-track difference a Cumulative Distribution Function (CDF) for each test-run was calculated.

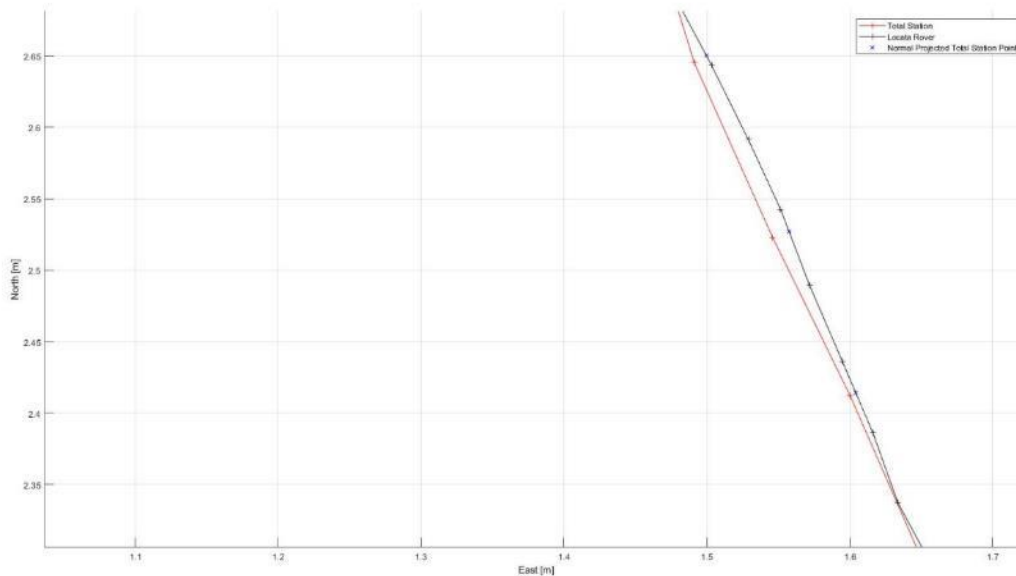

Figure 6-60: Example of Normal Projected Total Station Points to Locata Trajectory

6.2.2.1 Static Occupation Test Collection 1

Test collection 1 occupied seven points in the following order: 3, 6, 13, 14, 19, 20, and 23. The Locata Rover calculated a continuous position solution during the static occupation and when moving between static occupations. The position track of the rover is shown in Figure 6-61.

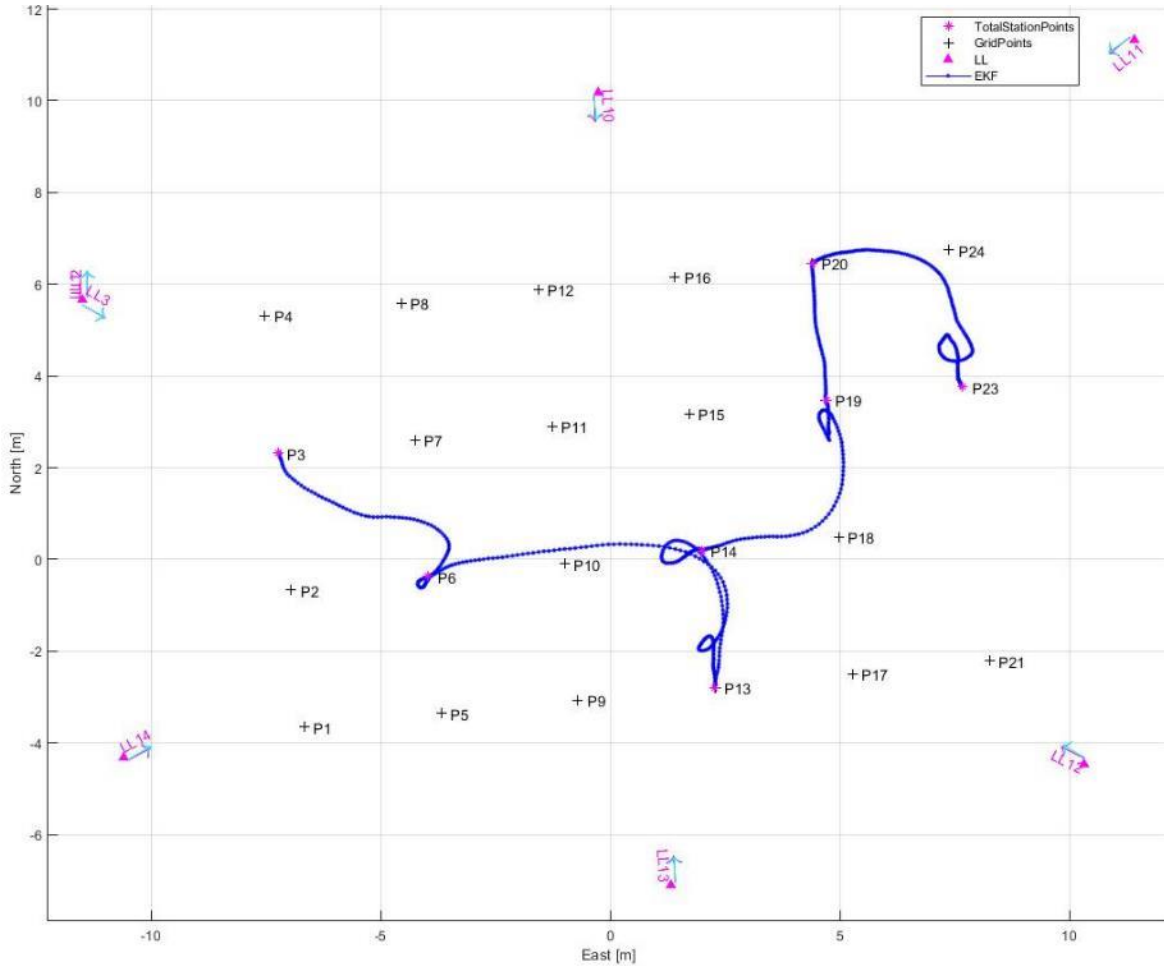

Figure 6-61: Locata Position Track for Static Occupation Test Collection 1

6.2.2.2 Static Occupation Test Collection 2

Test collection 2 occupied seven points in the following order: 20, 19, 14, 13, 6, 3, and 23. The Locata Rover calculated a continuous position solution during the static occupation and when moving between static occupations. The position track of the rover is shown in Figure 6-62.

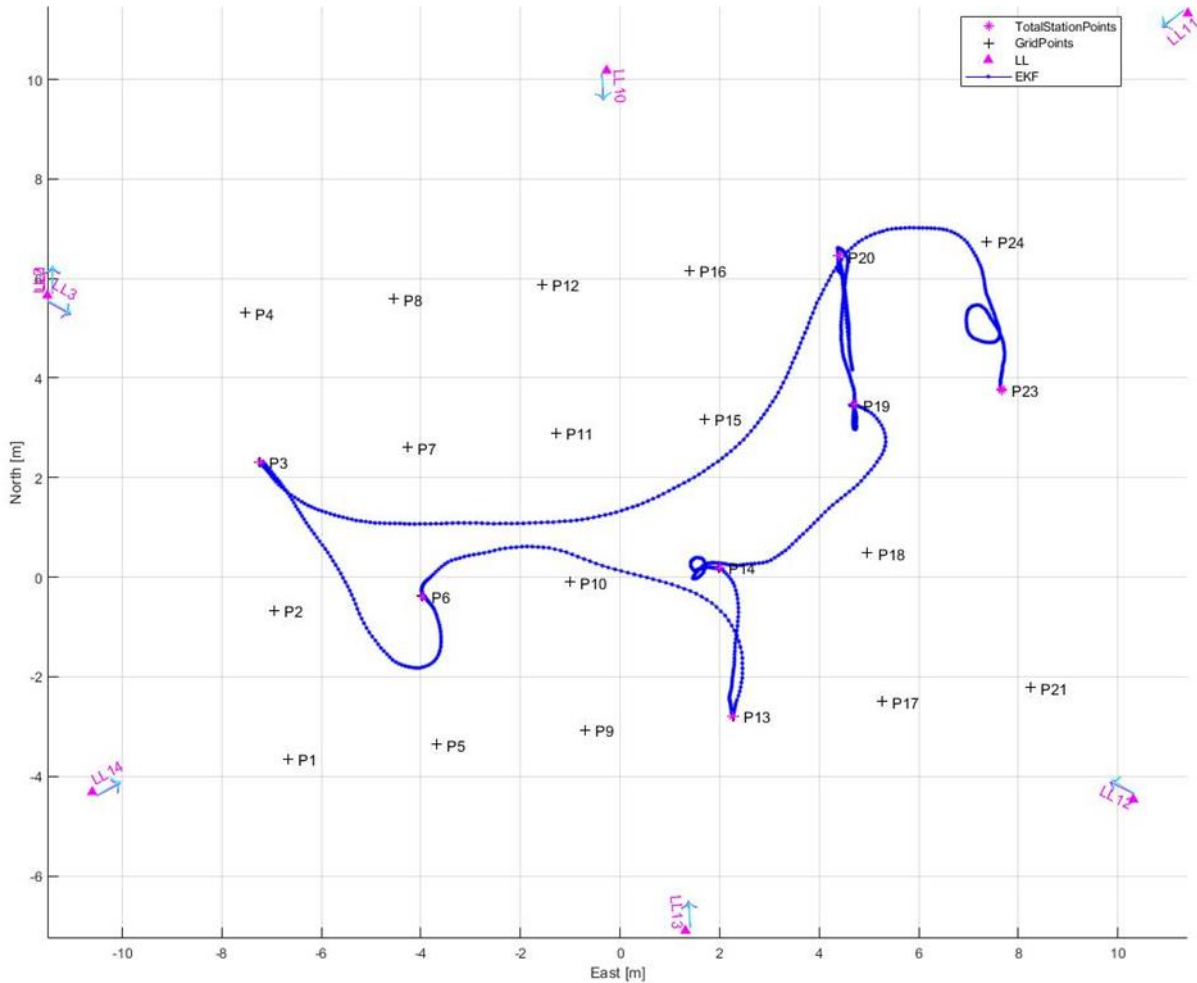

Figure 6-62: Locata Position Track for Static Occupation Test Collection 2

6.2.2.3 Static Positioning Results

Figure 6-63 shows the time series of the 2D difference between the Total Station position and the static occupations by the Locata Rover; and the calculated box plot is shown in Figure 6-64. The mean and standard deviation of the same data is presented in Figure 6-65, Figure 6-66 and Table 6-18.

These results show the centimetre-level performance of the indoor Locata Rover solution.

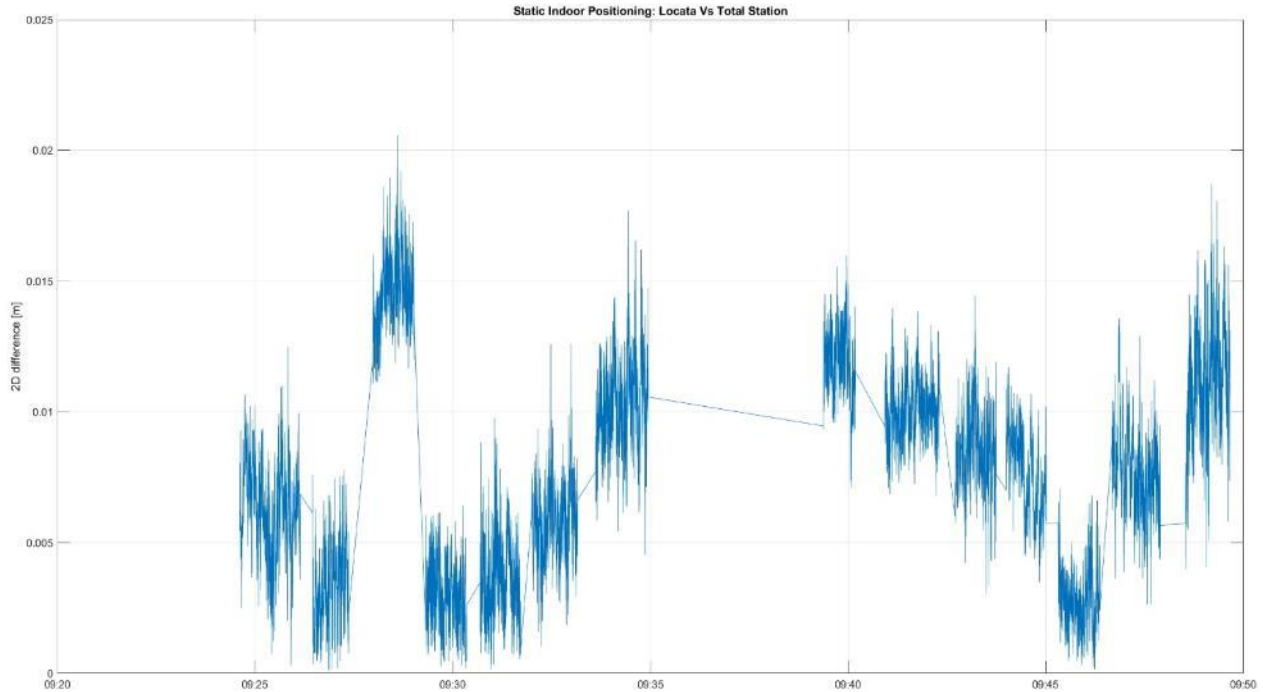

Figure 6-63: Time Series of the 2D Difference for all Static Occupations Compared to Total Station

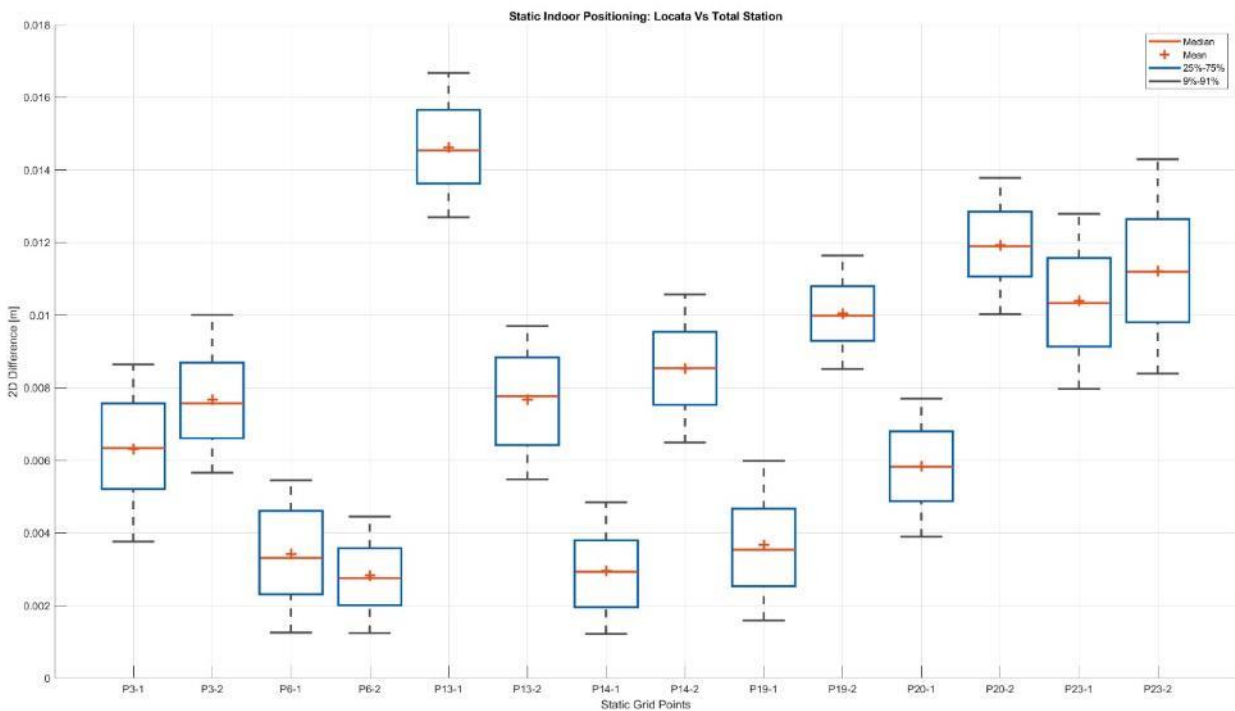

Figure 6-64: Box plot of the 2D Difference for all Static Occupations Compared to Total Station

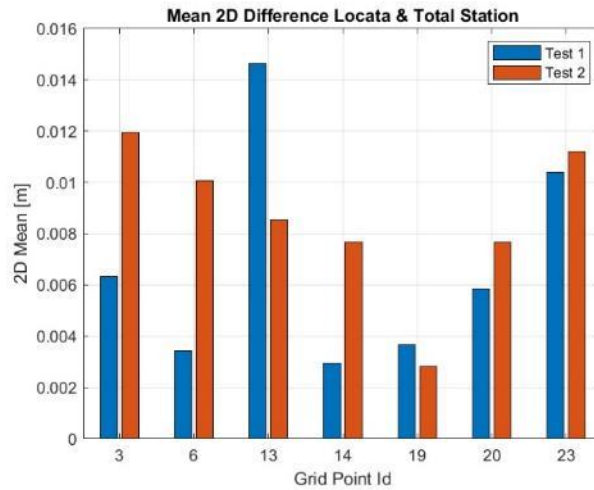

Figure 6-65: 2D Mean Position Error for all Static Occupations

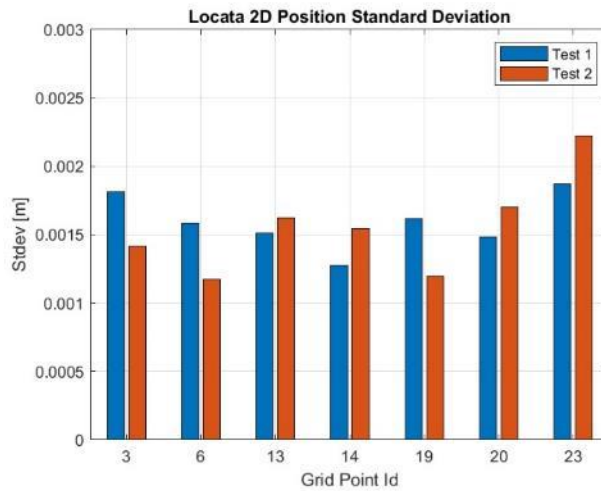

Figure 6-66: 2D Position Error Standard Deviations for all Static Occupations

Grid point ID	Mean (cm)		Standard Deviation (cm)	
	Test 1	Test 2	Test 1	Test 2
3	0.61	0.96	0.24	0.22
6	0.28	1.00	0.26	0.15
13	1.46	0.86	0.23	0.21
14	0.26	0.66	0.18	0.20
19	0.31	0.12	0.25	0.25
20	0.56	0.15	0.22	0.25
23	1.03	0.82	0.24	0.29

Table 6-18: Mean and Standard Deviations for all Static Occupations

6.2.2.4 Kinematic Positioning Test Collection 1

Kinematic test 1 was performed after initializing the Locata Rover within the indoor LocataNet. During this test the Locata Rover was primarily moved in a repeated East and West direction. The Locata Rover position track is shown in Figure 6-67.

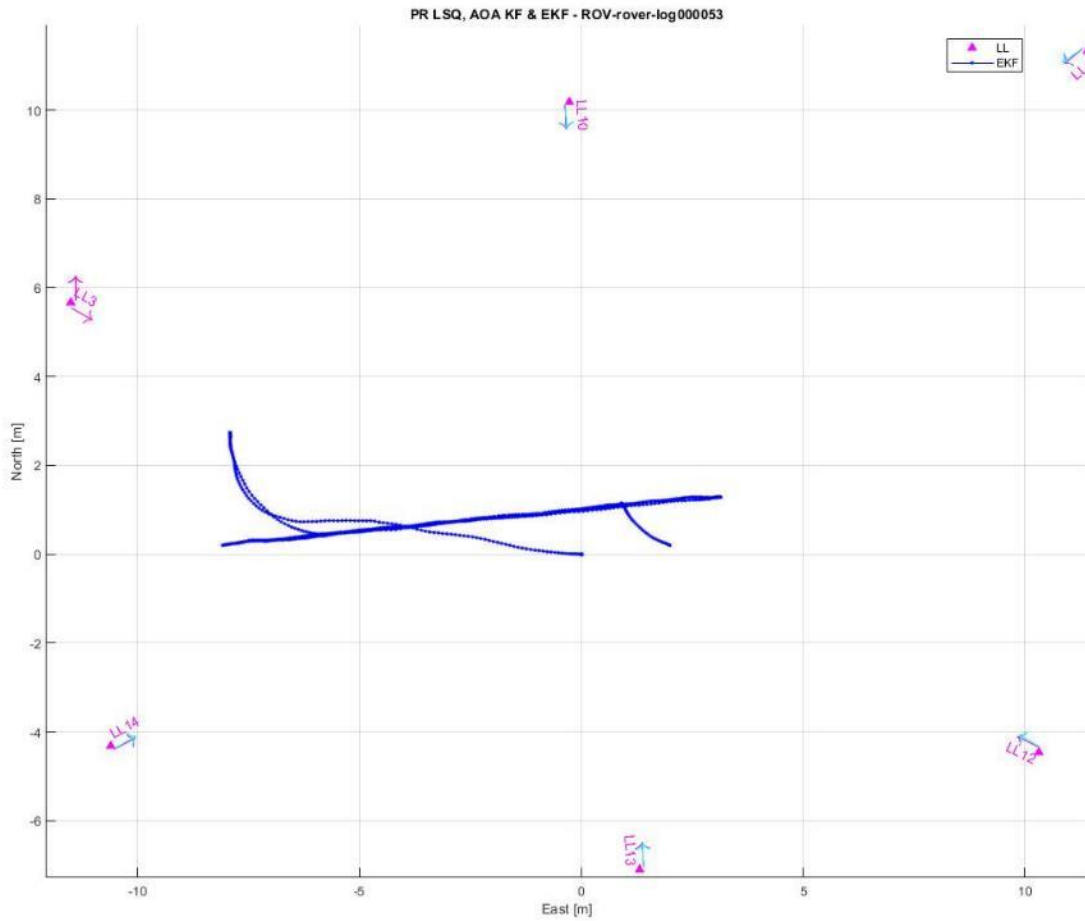

Figure 6-67: Locata Position Track for Kinematic Test Collection 1

6.2.2.5 Kinematic Positioning Test Collection 2

Kinematic test 2 was performed after initializing the Locata Rover within the indoor LocataNet. During this test the Locata Rover was moved repeatedly in both North/South and East/West directions. The Locata Rover position track is shown in Figure 6-68.

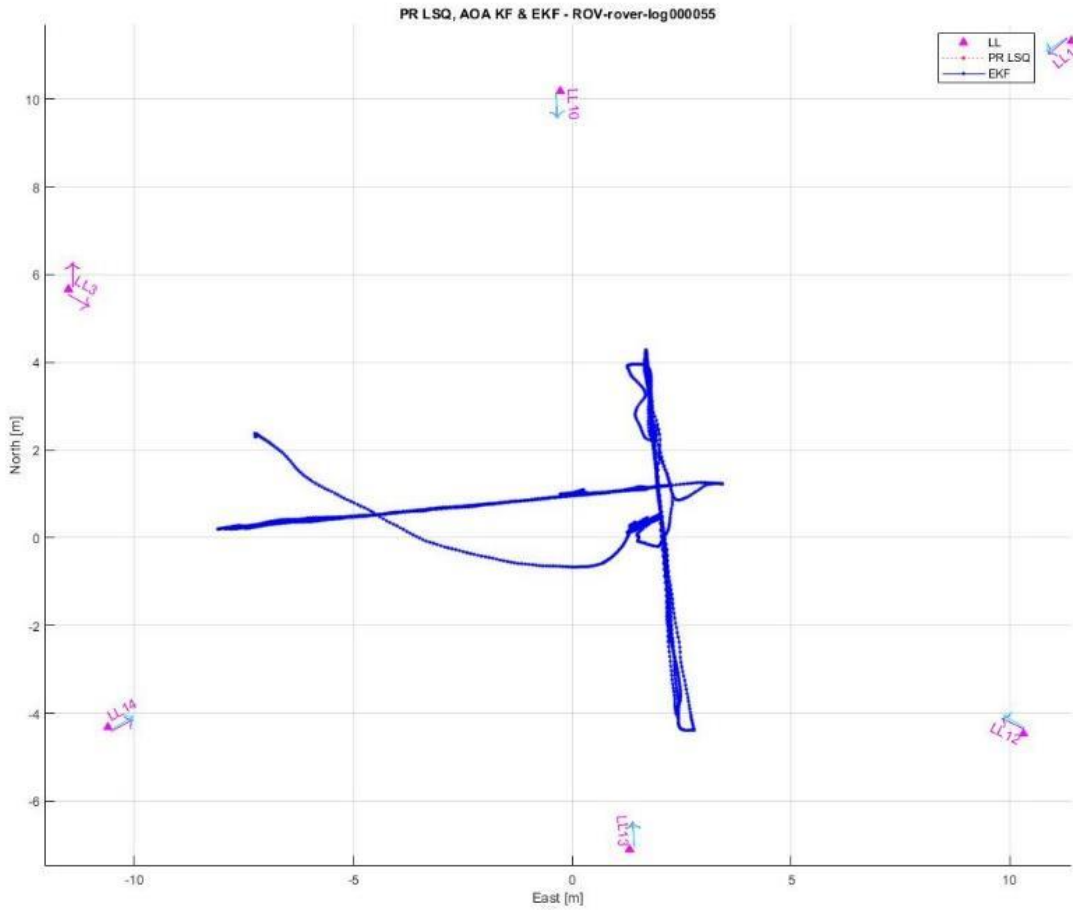

Figure 6-68: Locata Position Track for Kinematic Test Collection 2

6.2.2.6 Kinematic Positioning Test Results

The time series of the cross-track 2D difference between the Locata Rover and the Total Station for the first and second tests are shown in Figure 6-69 and Figure 6-71 respectively. The results of the kinematic positioning tests are shown with Cumulative Distribution Function plots in Figure 6-70 and Figure 6-72. During the first kinematic test the cross-track 2D difference between the Locata Rover and the Total Station was within 1cm for 90% of the time, and within 1.1cm for 90% of the time during the second test.

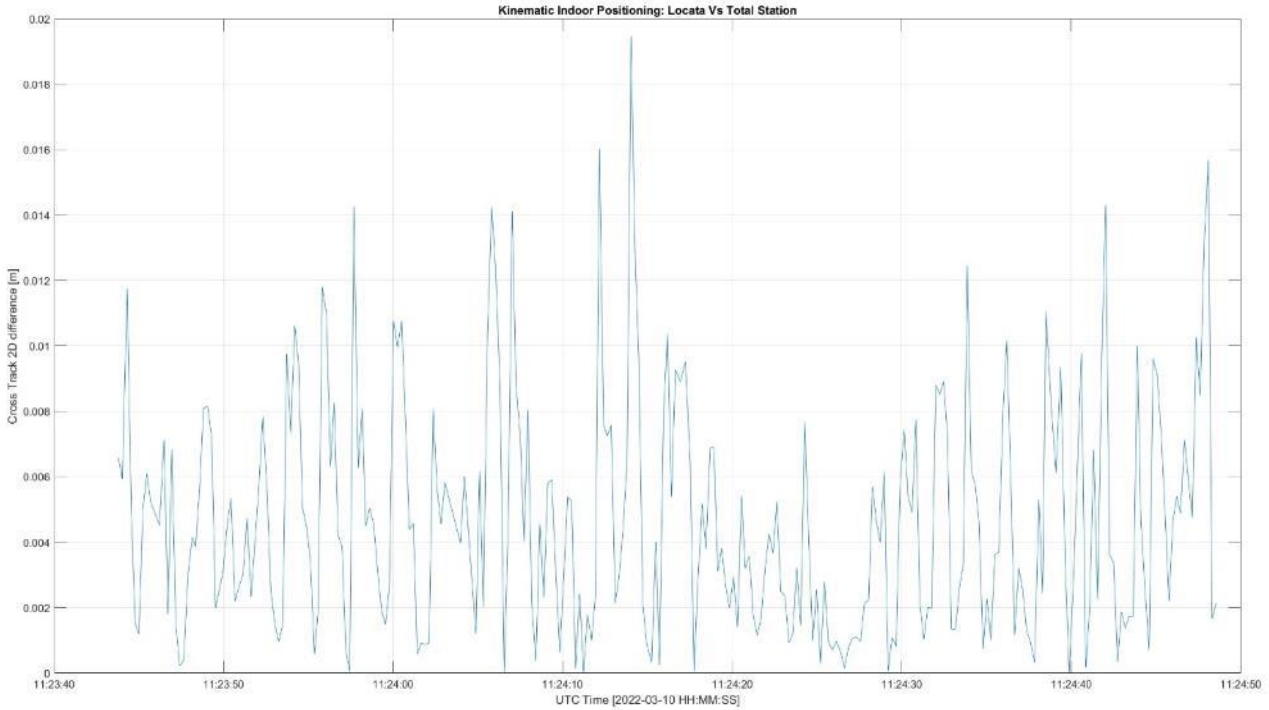

Figure 6-69: Time Series of the Cross-Track 2D Difference Between Locata Rover and Total Station for Indoor Kinematic Test Collection 1

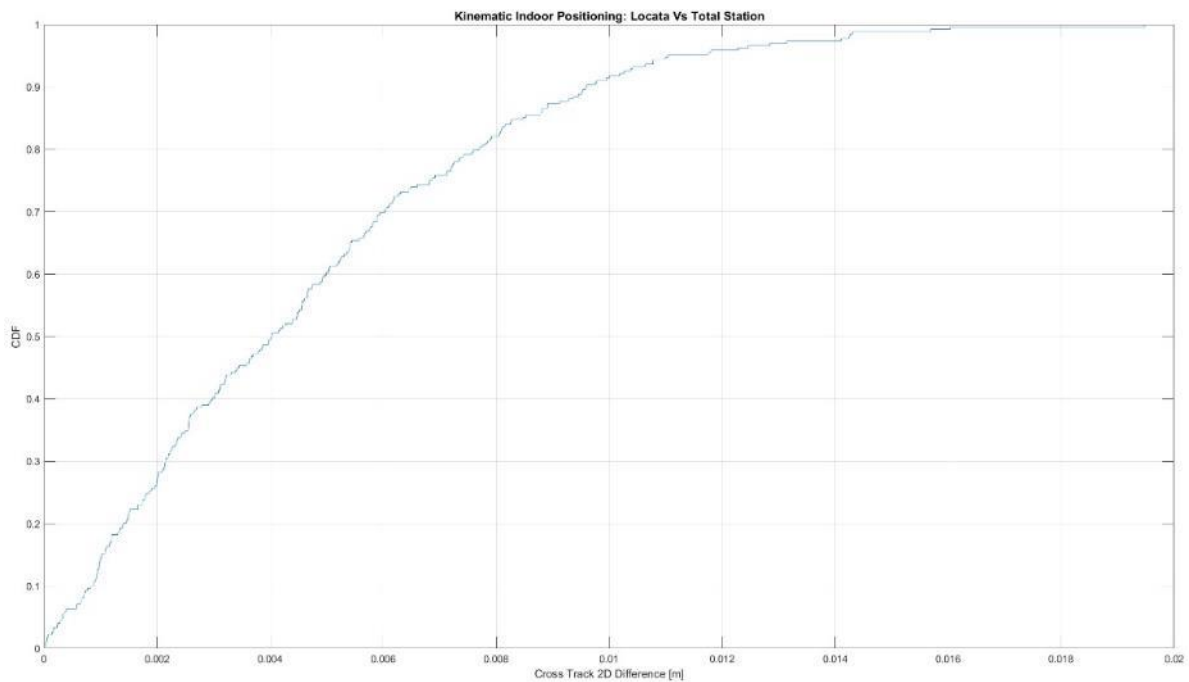

Figure 6-70: Cumulative Distribution Function for Kinematic Test Collection 1

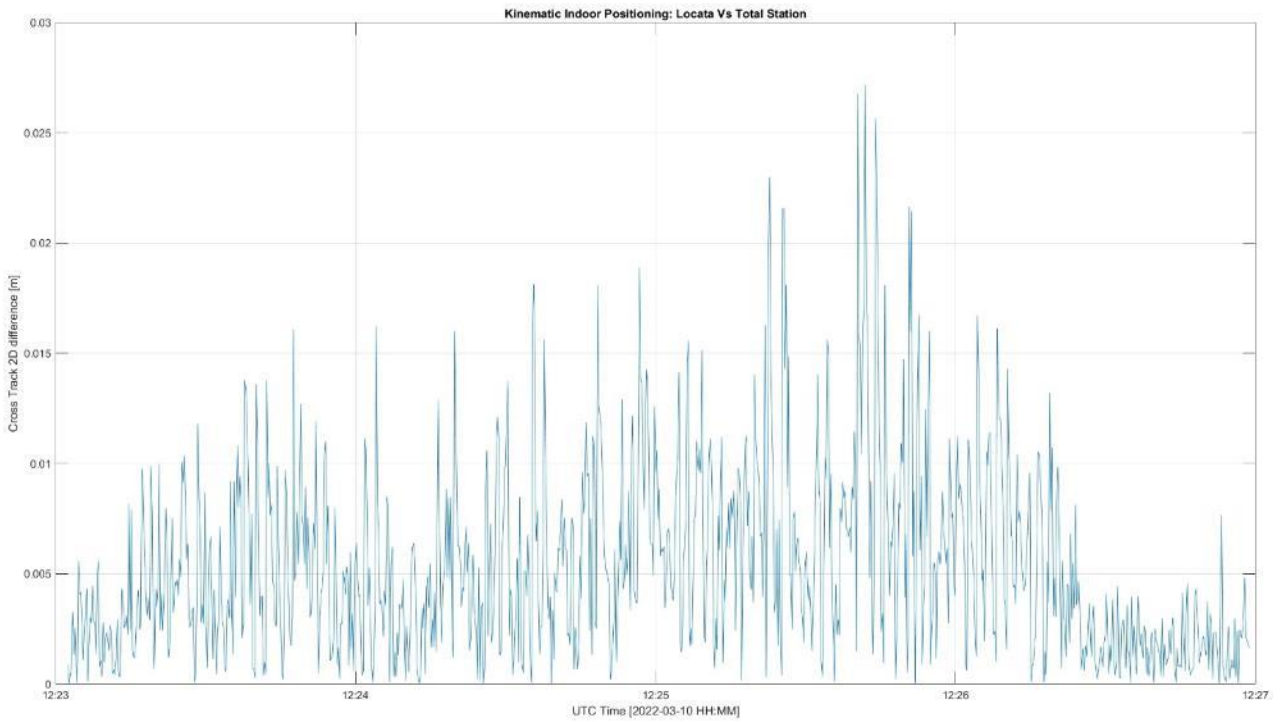

Figure 6-71: Time Series of the Cross-Track 2D Difference Between Locata Rover and Total Station for Indoor Kinematic Test Collection 2

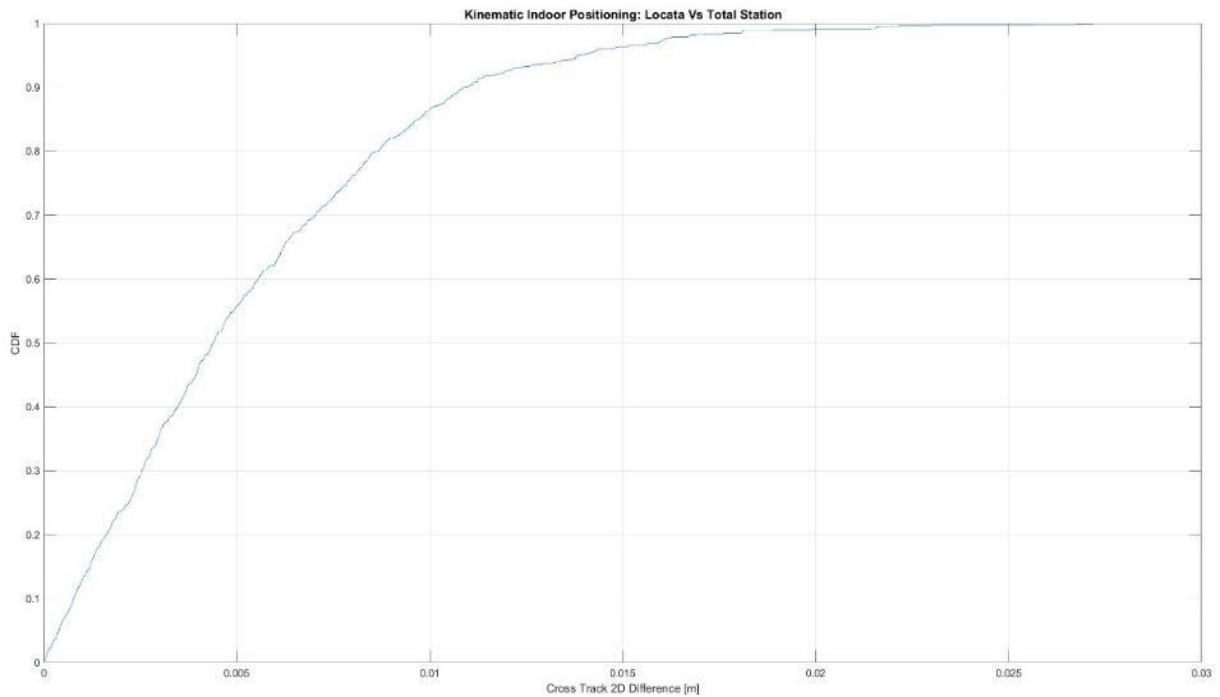

Figure 6-72: Cumulative Distribution Function for Indoor Kinematic Test Collection 2

6.2.3 Outdoor Positioning

Both static and kinematic outdoor positioning were evaluated at a Locata customer site owned by Konecranes in Düsseldorf, Germany. A laser Total Station was used as a reference for the static positioning tests and GNSS RTK was used as a reference for the kinematic positioning tests.

For static comparison a single Total Station point was recorded as reference, as the Locata Rover platform was not moving during each occupation. The Locata Rover position was then compared to these individual Total Station points for each static location.

For kinematic comparison, the asynchronous time base and varying sampling rate of the Total Station prevented a direct comparison to the Locata Rover positions, therefore a GNSS RTK position was used as a reference. The SAPOS NTRIP correction service was used to deliver RTCM corrections to the GNSS receiver. Due to differences in the Total Station control network and the SAPOS RTK correction service, a correction of East +14mm and North -31mm was added to the GNSS data. The Locata Rover positions were recorded at a 10 Hz rate synchronous with the LocataNet. This enabled direct comparison between the Locata Rover and GNSS positioning solutions since the LocataNet was synchronized to GNSS.

To evaluate applicability of GNSS RTK as a reference for Locata kinematic positioning, GNSS position solutions were compared to Total Station position solutions during static positioning tests.

6.2.3.1 Static Occupation Test Collection

Test collections occupied a total of 16 points with a variable number of reoccupations. The most occupied point was point 1 with total of 11 occupations, while point 16 was occupied only once. The Locata Rover calculated a continuous positioning solution during the static occupations and when moving between static occupations. The position track of the rover is shown in Figure 6-73.

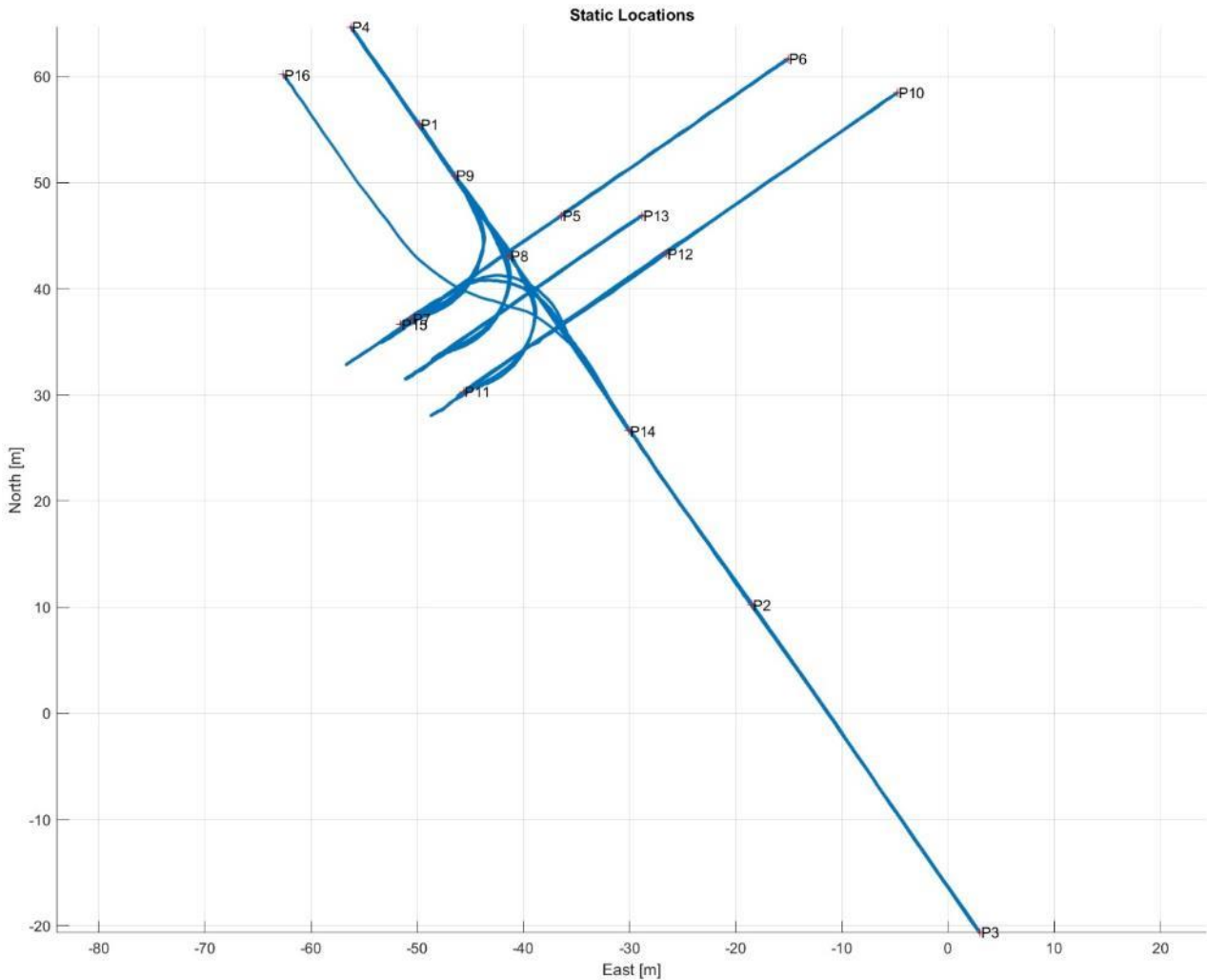

Figure 6-73: Locata Position Track for the Outdoor Static Test

6.2.3.2 Static Positioning Results

Figure 6-74 shows the time series of the 2D difference between the Total Station position and the Locata Rover static occupations; and the calculated box plot is shown in Figure 6-75. The mean and standard deviation are also presented in Figure 6-76, Figure 6-77 and Table 6-19.

These results show the centimetre-level performance of the outdoor Locata Rover position solutions.

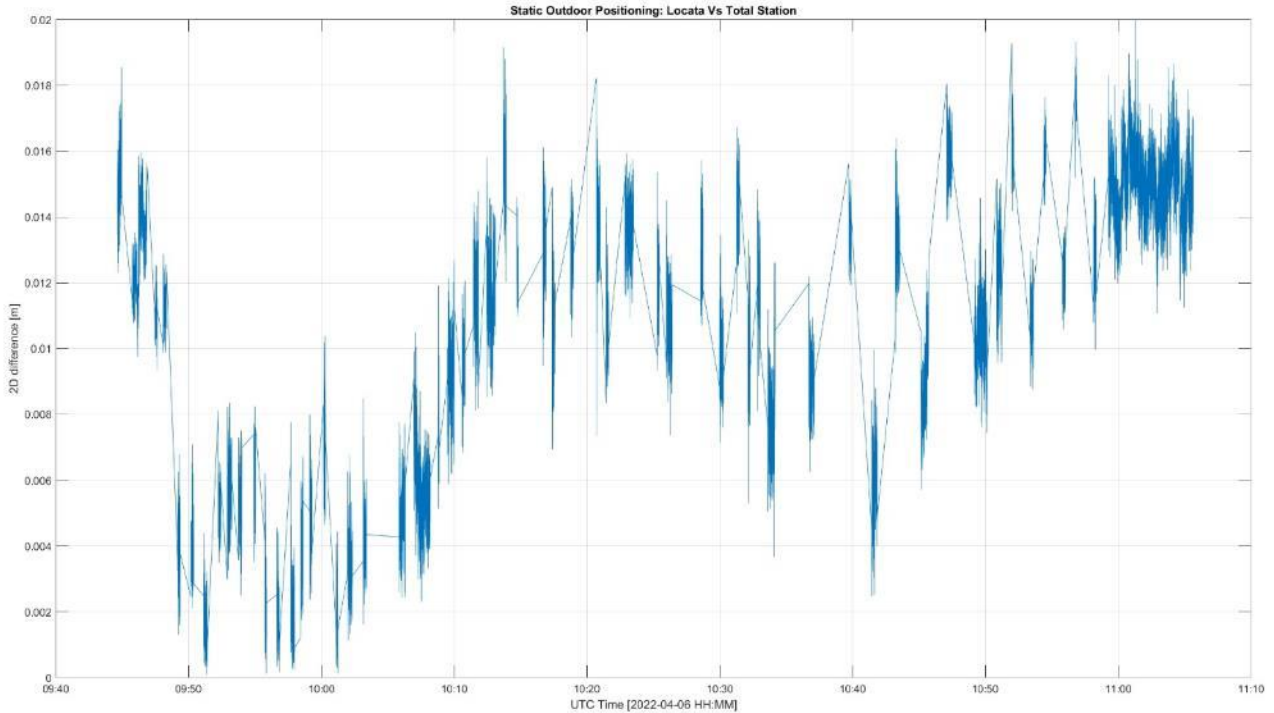

Figure 6-74: Time Series of the 2D Difference for all Locata Outdoor Static Occupations Compared to Total Station

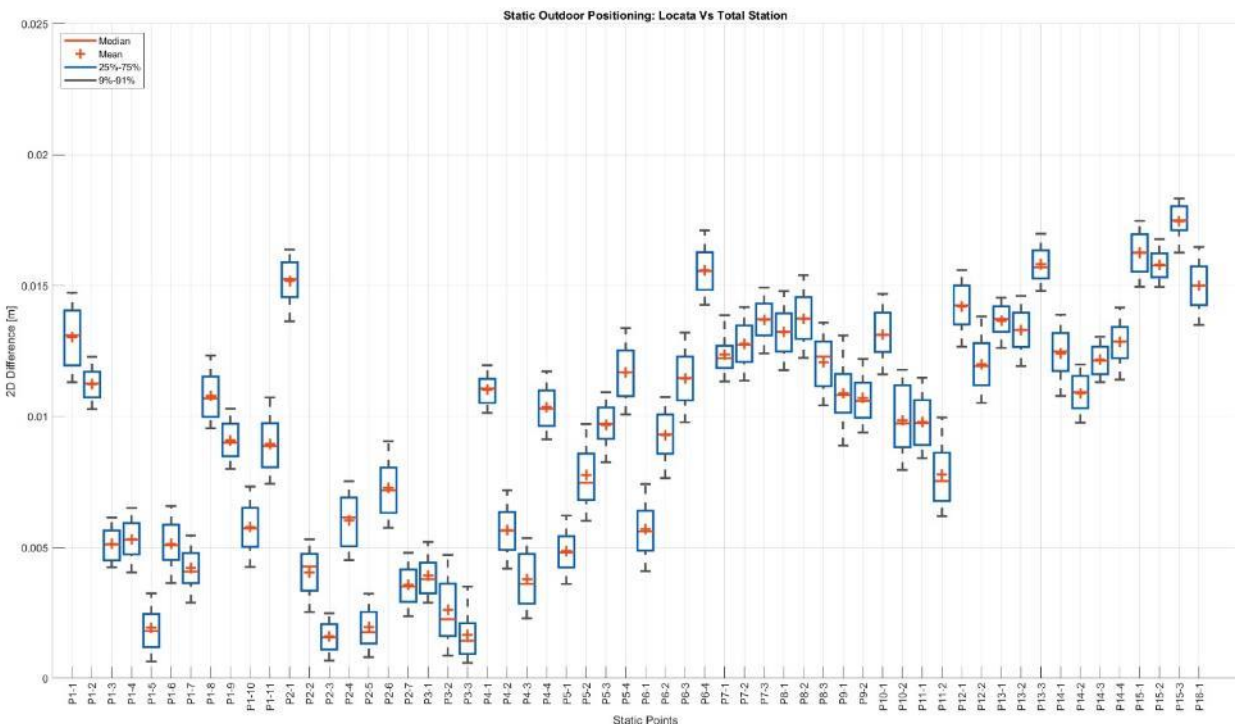

Figure 6-75: Box Plot of the 2D Difference for all Locata Outdoor Static Occupations Compared to Total Station

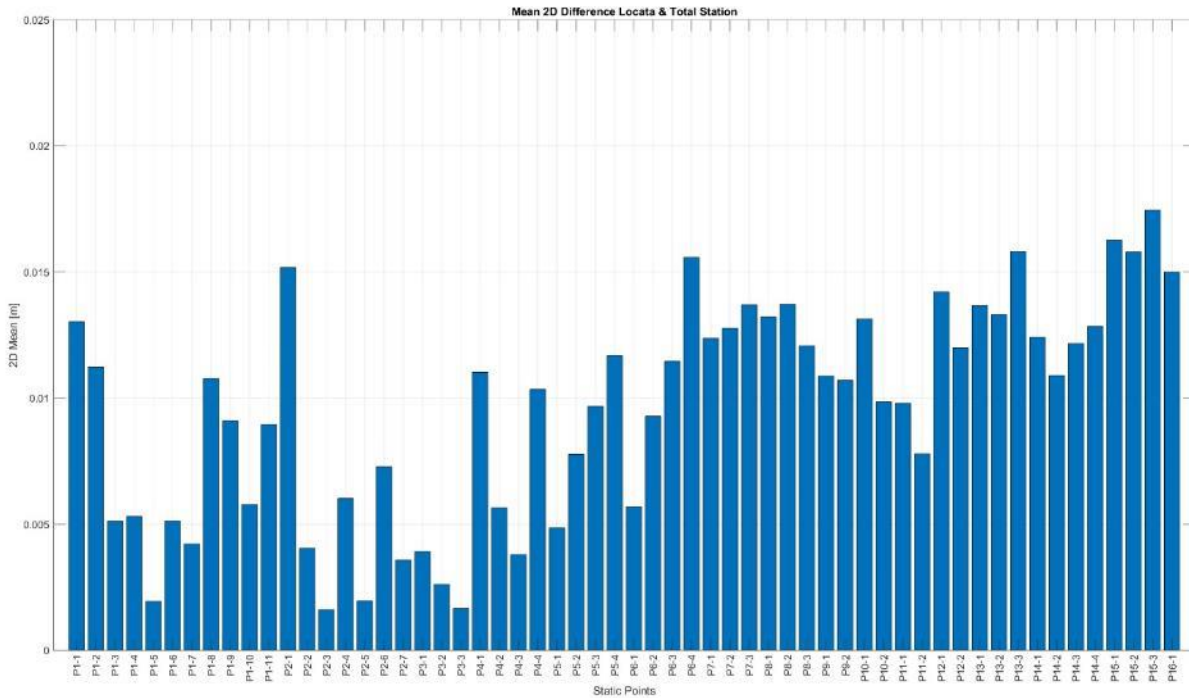

Figure 6-76: 2D mean Positioning Error for all Locata Outdoor Static Occupations

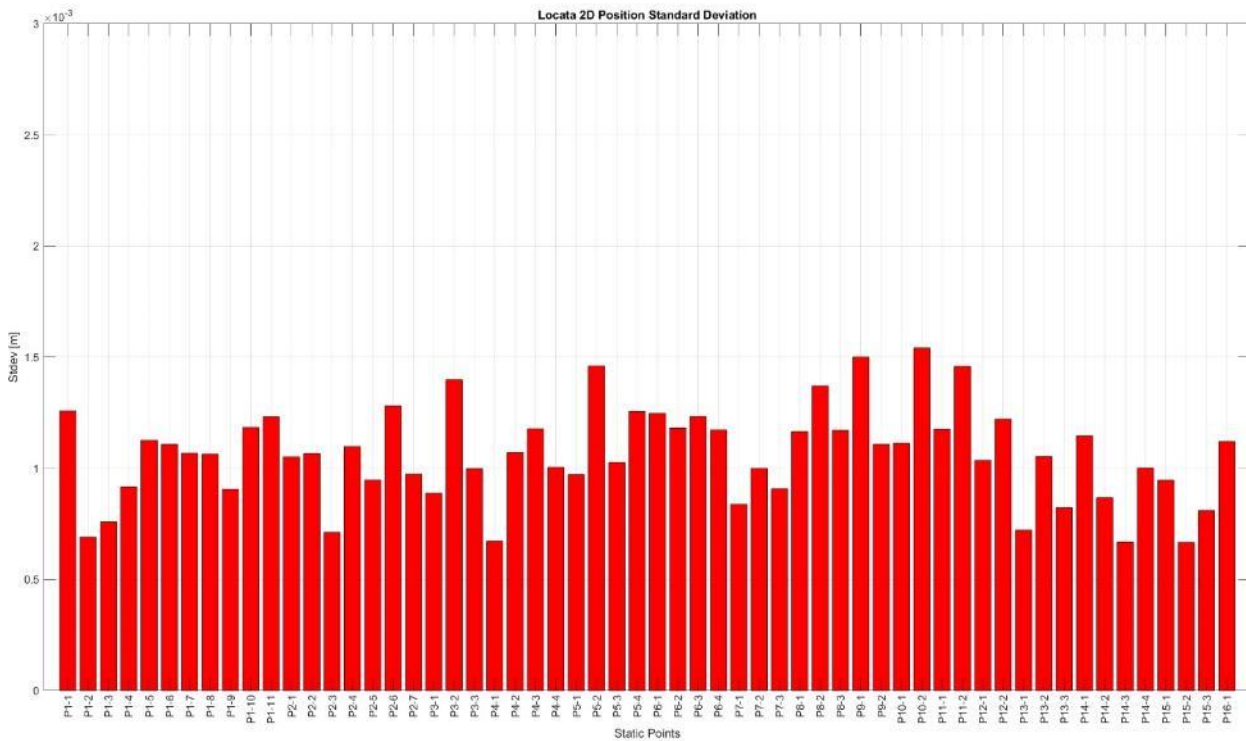

Figure 6-77: 2D Positioning Error Standard Deviations for all Locata Outdoor Static Occupations

Point	Mean (cm)	Standard Deviation
P1-1	1.30	0.13
P1-2	1.12	0.07
P1-3	0.51	0.08
P1-4	0.53	0.09
P1-5	0.19	0.11
P1-6	0.51	0.11
P1-7	0.42	0.11
P1-8	1.08	0.11
P1-9	0.91	0.09
P1-10	0.58	0.12
P1-11	0.90	0.12
P2-1	1.52	0.11
P2-2	0.41	0.11
P2-3	0.16	0.07
P2-4	0.60	0.11
P2-5	0.20	0.09
P2-6	0.73	0.13
P2-7	0.36	0.10
P3-1	0.39	0.09
P3-2	0.26	0.14
P3-3	0.17	0.10
P4-1	1.10	0.07
P4-2	0.57	0.11
P4-3	0.38	0.12
P4-4	1.04	0.10
P5-1	0.49	0.10
P5-2	0.78	0.15
P5-3	0.97	0.10
P5-4	1.17	0.13

Point	Mean (cm)	Standard Deviation
P6-1	0.57	0.12
P6-2	0.93	0.12
P6-3	1.15	0.12
P6-4	1.56	0.12
P7-1	1.24	0.08
P7-2	1.28	0.10
P7-3	1.37	0.09
P8-1	1.32	0.12
P8-2	1.37	0.14
P8-3	1.21	0.12
P9-1	1.09	0.15
P9-2	1.07	0.11
P10-1	1.31	0.11
P10-2	0.99	0.15
P11-1	0.98	0.12
P11-2	0.78	0.15
P12-1	1.42	0.10
P12-2	1.20	0.12
P13-1	1.37	0.07
P13-2	1.33	0.11
P13-3	1.58	0.08
P14-1	1.24	0.11
P14-2	1.09	0.09
P14-3	1.22	0.07
P14-4	1.29	0.10
P15-1	1.63	0.09
P15-2	1.58	0.07
P15-3	1.75	0.08
P16-1	1.50	0.11

Table 6-19: Mean and Standard Deviations for all Locata Outdoor Static Occupations

6.2.3.3 Testing GNSS as a Reference

Figure 6-78 is a box plot showing the difference between the Total Station positions and GNSS RTK position solutions during the static occupations. The mean and standard deviation are also presented in Figure 6-79, Figure 6-80 and Table 6-20.

These results show centimetre-level performance of the GNSS RTK position solutions. A similar level of performance is achieved by both Locata and GNSS RTK during the static occupations.

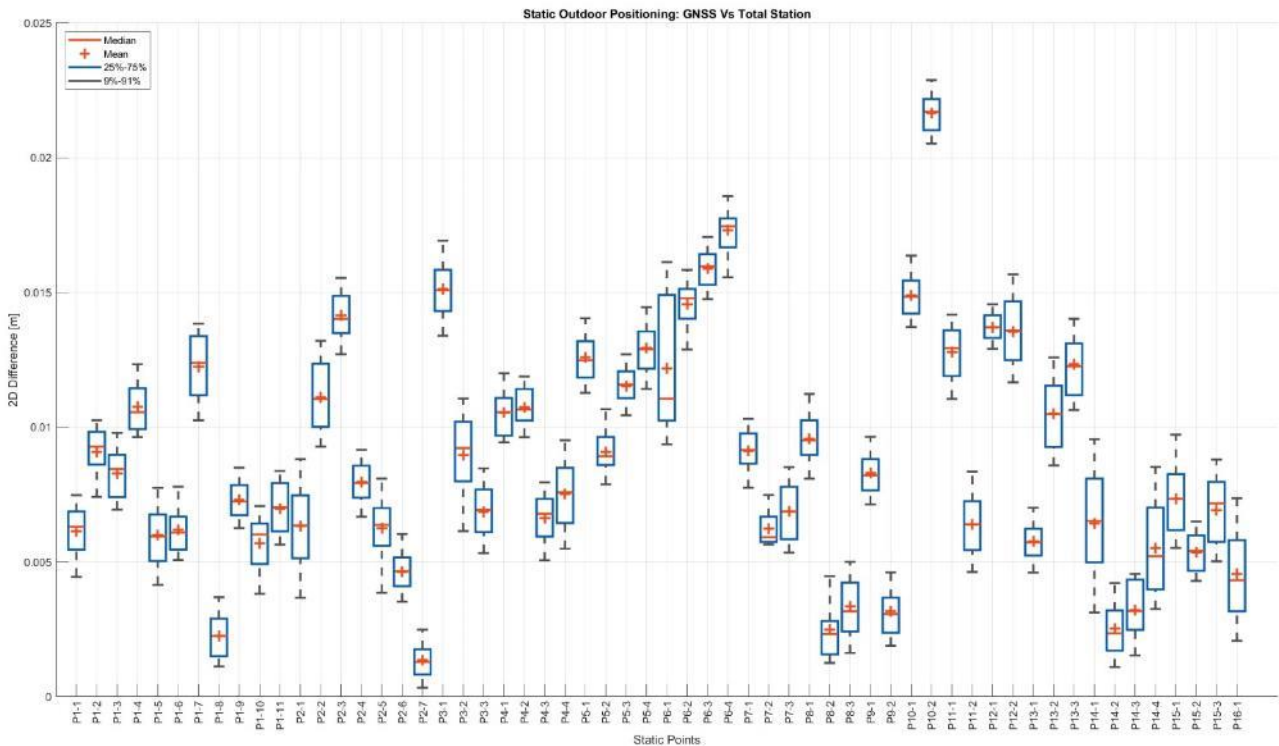

Figure 6-78: Box Plot of the 2D Difference of GNSS RTK Positioning Solutions for all Outdoor Static Occupations Compared to Total Station

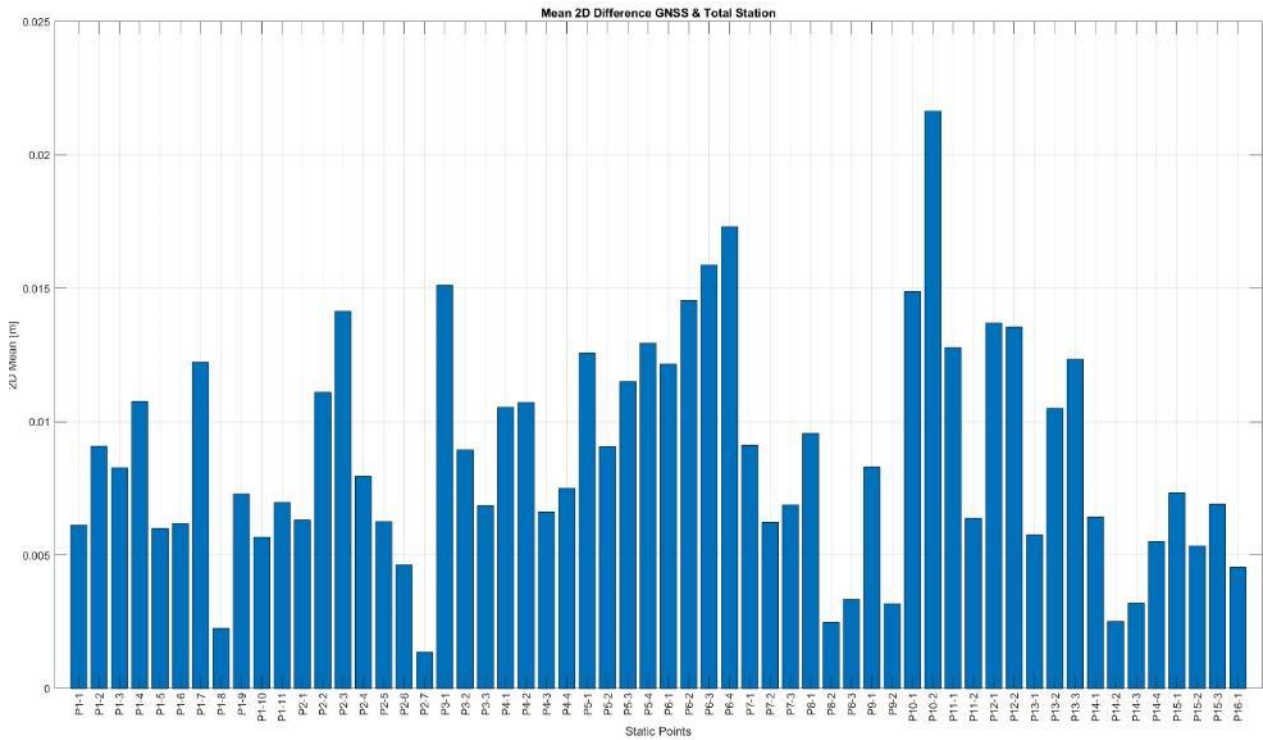

Figure 6-79: Mean Positioning Error of the GNSS RTK Positioning Solutions for all Outdoor Static Occupations

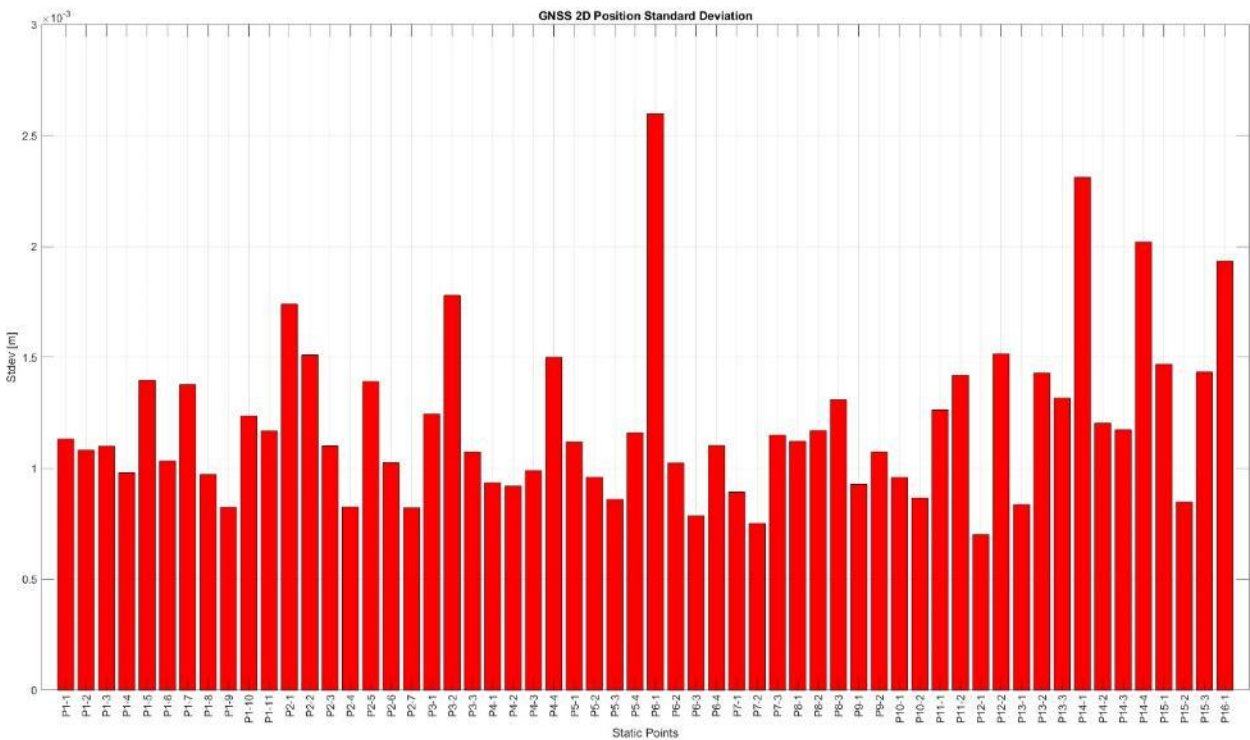

Figure 6-80: 2D Positioning Error Standard Deviations of the GNSS RTK Positioning Solutions for all Outdoor Static Occupations

Point	Mean (cm)	Standard Deviation (cm)
P1-1	0.61	0.11
P1-2	0.91	0.11
P1-3	0.83	0.11
P1-4	1.08	0.10
P1-5	0.60	0.14
P1-6	0.62	0.10
P1-7	1.22	0.14
P1-8	0.23	0.10
P1-9	0.73	0.08
P1-10	0.57	0.12
P1-11	0.70	0.12
P2-1	0.63	0.17
P2-2	1.11	0.15
P2-3	1.42	0.11
P2-4	0.80	0.08
P2-5	0.63	0.14
P2-6	0.46	0.10
P2-7	0.14	0.08
P3-1	1.51	0.12
P3-2	0.90	0.18
P3-3	0.69	0.11
P4-1	1.05	0.09
P4-2	1.07	0.09
P4-3	0.66	0.10
P4-4	0.75	0.15
P5-1	1.26	0.11
P5-2	0.91	0.10
P5-3	1.15	0.09
P5-4	1.29	0.12

Point	Mean (cm)	Standard Deviation (cm)
P6-1	1.22	0.26
P6-2	1.46	0.10
P6-3	1.59	0.08
P6-4	1.73	0.11
P7-1	0.91	0.09
P7-2	0.62	0.08
P7-3	0.69	0.12
P8-1	0.96	0.11
P8-2	0.25	0.12
P8-3	0.33	0.13
P9-1	0.83	0.09
P9-2	0.32	0.11
P10-1	1.49	0.10
P10-2	2.17	0.09
P11-1	1.28	0.13
P11-2	0.64	0.14
P12-1	1.37	0.07
P12-2	1.36	0.15
P13-1	0.58	0.08
P13-2	1.05	0.14
P13-3	1.23	0.13
P14-1	0.64	0.23
P14-2	0.25	0.12
P14-3	0.32	0.12
P14-4	0.55	0.20
P15-1	0.73	0.15
P15-2	0.53	0.08
P15-3	0.69	0.14
P16-1	0.46	0.19

Table 6-20: Mean and Standard Deviation of the GNSS RTK Positioning Solutions for all Outdoor Static Occupations

6.2.3.4 Kinematic Positioning Test Collection

A total of six routes were driven for the kinematic tests. Each route was driven with two to four repetitions. Routes were driven in between the static occupations as shown in Figure 6-73.

The first route was driven from point P4 to P1 and return with stops for static data collection at points P2 and P3. This route was repeated four times.

The second route was driven from point P5 to P6 and return and was repeated three times.

The third route was driven from point P7 to point P8 stopping at P9, repeating twice.

The fourth route was driven in a loop starting from point P12 and going through P10 and P11, repeating twice.

The fifth route was driven from point P1 to P13, repeating three times.

The sixth route was driven from point P14 to P15 and return, repeating three times.

Data collection finished at point P16.

6.2.3.5 Kinematic Positioning Test Results

The time series of the 2D difference between the Locata Rover and the GNSS receiver is shown in Figure 6-81. At approximately 10:34 there was a 2D difference spike of 0.033m. Analysis of the velocity derived from GNSS position solution data showed a larger than expected velocity jump from the data trend. This has likely contributed to the spike in the 2D difference with the Locata Rover as shown in Figure 6-82.

The results of the outdoor kinematic positioning test are shown in Figure 6-83 with a Cumulative Distribution Function plot. The 2D difference between the Locata Rover and the GNSS solutions were within 1.7 cm for 90% of the time. Locata and GNSS solutions showed similar, centimetre level accuracy when Total Station solutions were used as a reference.

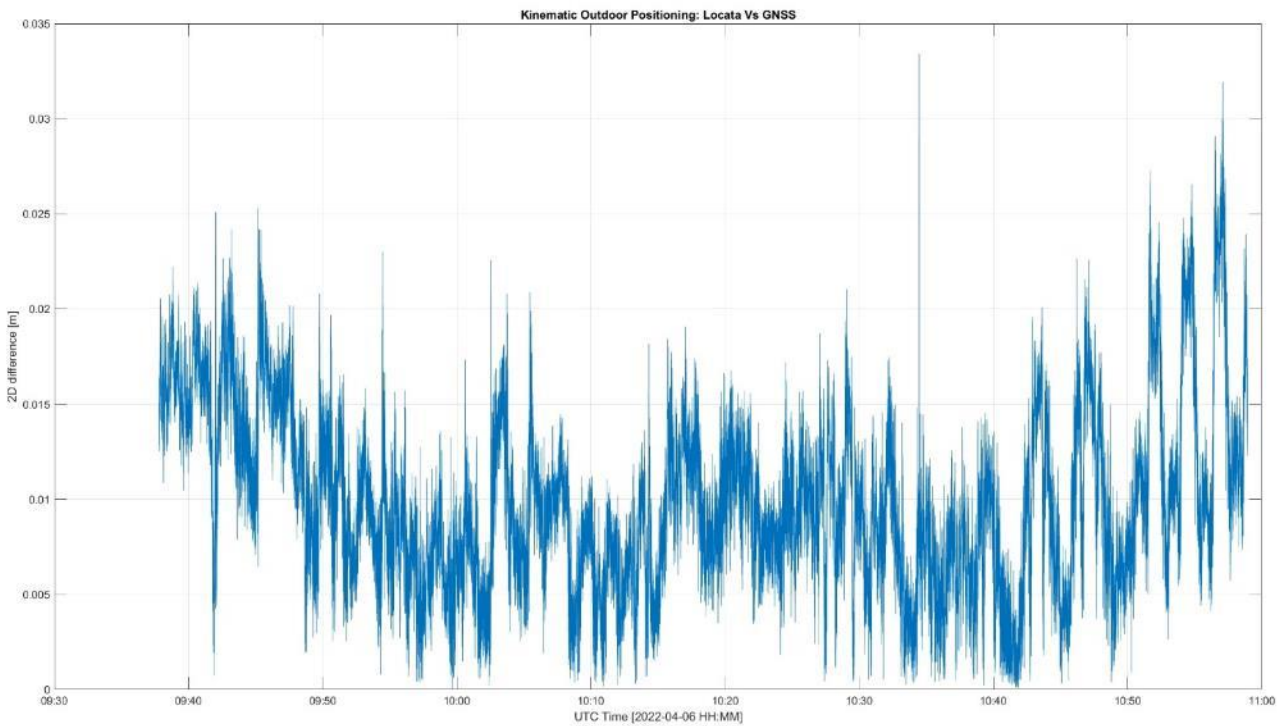

Figure 6-81: Time Series of the 2D Difference Between Locata Rover and GNSS Receiver for Outdoor Kinematic Test

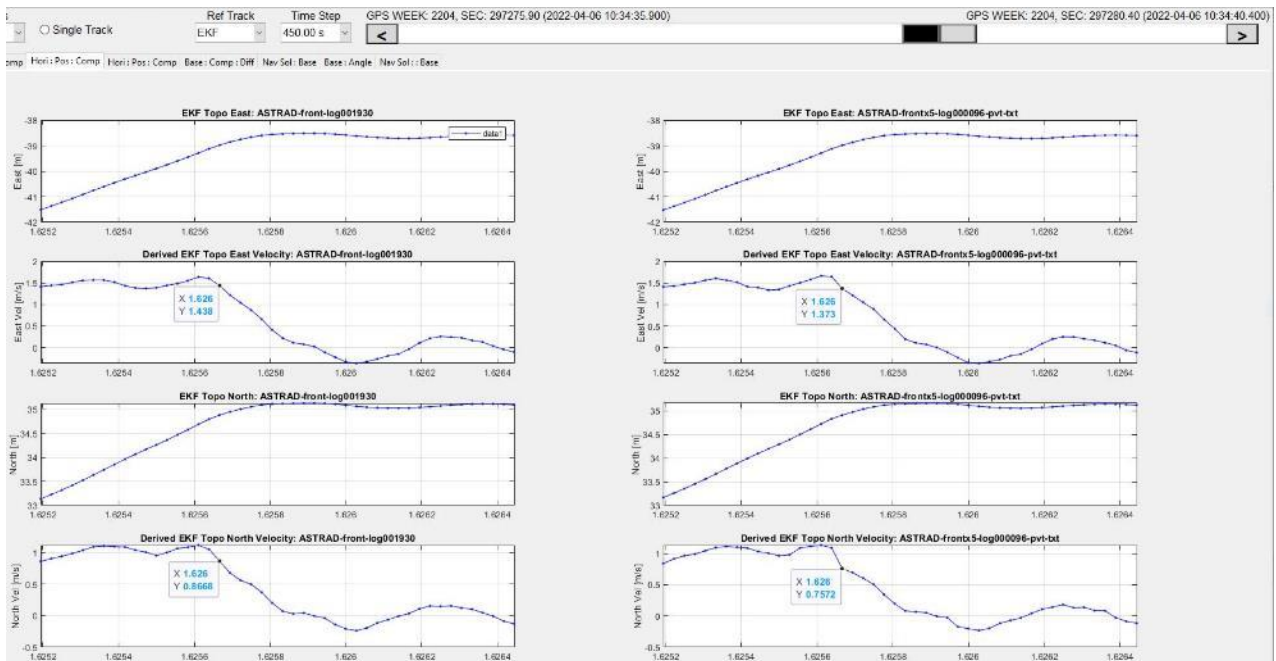

Figure 6-82: Component East and North Position with Derived Velocity for Locata Rover (left) and GNSS Receiver (right)

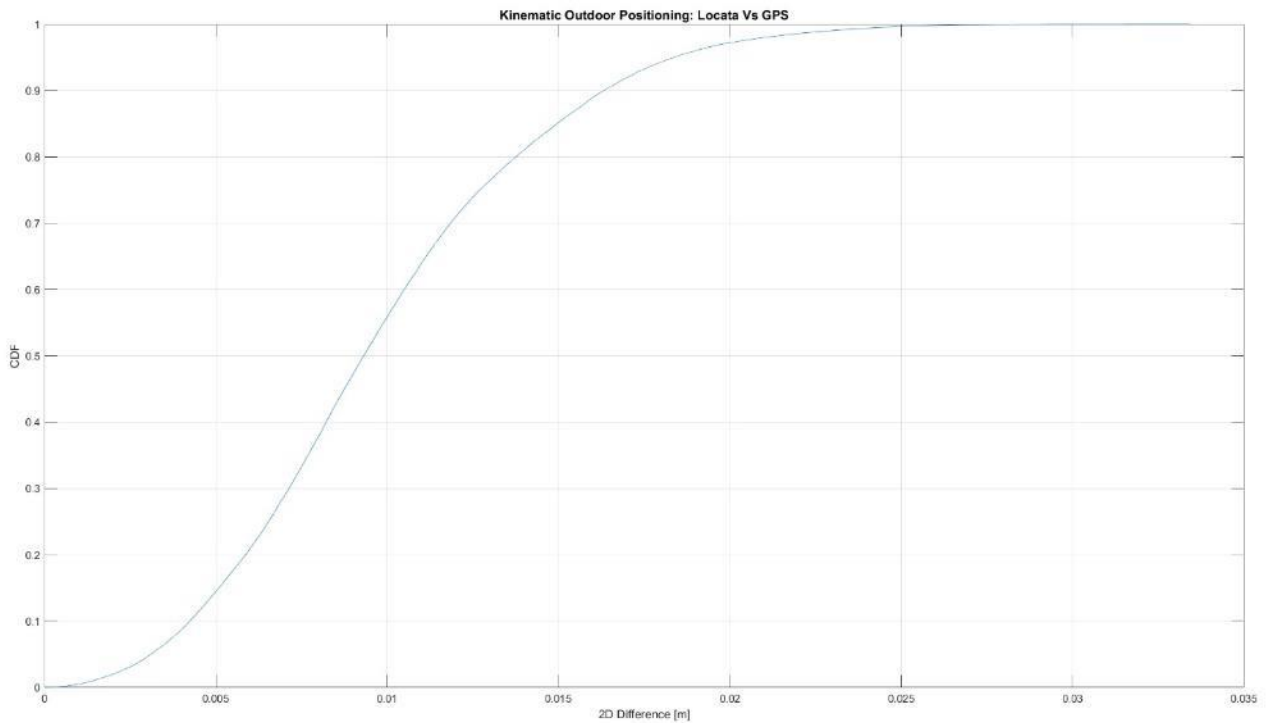

Figure 6-83: Cumulative Distribution Function for the Outdoor Kinematic Test

6.3 Resilience & Network Monitoring Performance

This section presents network monitoring and resilience capabilities using webpage captures from relevant devices.

6.3.1 Network in Normal Operation

LocataLites 11, 12, and 13 were synchronized with TimeLoc Bracing to signals from both the Primary Master (LocataLite 10), and Secondary Master (LocataLite 14). The following are screenshots from LocataLites 10 and 14 showing their status, respectively, as Primary Master and Secondary Master.

TimeLoc Bracing Status	
LocataLite ID 10 DEFIS-10-Indoor1	
Message Time - Meas Sync	2022/03/24 13:11:59.540 (LocataNet internal time) : TimeLoc This Device's measurements are aligned to the LocataNet second boundary
LocataLite ID	10
LocataNet ID	1
LocataLite Role	Master
TimeLoc State	Master Locked - 163
TimeLoc Bracing	Enabled
Tx Freq Offset (ppb)	0.000

TimeLoc Bracing Status		
LocataLite ID 14 DEFIS-14-Indoor5		
Message Time - Meas Sync	2022/03/24 13:12:06.320 (LocataNet internal time) : TimeLoc This Device's measurements are aligned to the LocataNet second boundary	
LocataLite ID	14	
LocataNet ID	1	
LocataLite Role	Slave	
Dual Master Status	Alternate Master (Ready To Take Over)	
TimeLoc State	TimeLoc'd - 190	
TimeLoc Quality	Excellent	
TimeLoc Bracing	Enabled	
TimeLoc Local Signal	14B	
TimeLoc Ref Signal	10C	
Tx Freq Offset (ppb)	106.976	
Tx Freq Offset Filtered (ppb)	106.973	
Tx Freq Offset Filtered Lagged (ppb)	106.974	
ICP Diff Raw (cycles)	0.000	
ICP Diff variation (cycles)	0.014	
ICP Diff stdev (cycles)	0.002	
TimeLoc ICP filtered (cycles)	0.000	
Bracing LocataLite Count	1	
EKF Input Measurement Count	4	
EKF Valid Measurement Count	4	
EKF Iteration Count	4956309	
EKF Prediction Count	0	
EKF Phase Quality (95%) (cycles)	0.004	
EKF Phase Error (cycles)	0.000	
EKF Freq Error (Hz)	0.011	
EKF P[2][2]	0.000004189, 0.000002503, 0.000002503, 0.000033167	
EKF Pred Phase Quality (95%) (cycles)	0.005	
EKF Pred Phase Error (cycles)	0.001	
EKF Pred Freq Error (Hz)	0.006	
EKF Pred P[2][2]	0.000005302, 0.000003171, 0.000003171, 0.000033567	
EKF Abs Freq Offset (ppb)	106.970	
LocataLite Info		
LocataLite ID	14	10
Rank	0	1
TimeLoc Hops to Master	1	0
Usable Signal Count	2	4
ICP Difference Average (cycles)	-0.006	0.000
ICP Difference Spread (cycles)	0.012	0.170

6.3.2 LocataLite 10 - Powered Down

The Rover's web page continued to indicate a centimetre level position solution while only tracking the four remaining LocataLites 11, 12, 13 and 14.

The Secondary Master's web page (LocataLite 14) indicated its role was now Active Alternate Master.

LocataLite 11's web page indicated it was still in TimeLoc but now without using signals from LocataLite 10.

The following are web page screen shots from the Rover, Secondary Master (LocataLite 14), and Slave LocataLite 11.

Nav Solution (Ext)	
Rover SN21008	
Solution Time 2022/03/24 13:46:54.600000012 (LocataNet internal time) : Navigation Solution	
- Meas Sync This Device's measurements are aligned to the LocataNet second boundary	

Solution Validity	Valid solution computed
Position	Position centimeter
- Latitude (deg)	45.812630378
- Longitude (deg)	8.628993202
- Height (m)	261.880
- ECEF XYZ (m)	4403049.395, 668177.810, 4550943.875
- Position Quality RMS (95%) (m)	0.026
Velocity	Known
- Speed Over Ground (SOG) (km/hr)	0.102
- Speed Over Ground (SOG) (m/s)	0.028
- SOG Quality RMS (95%) (m/s)	0.417
- Easting (m/s)	-0.020
- Northing (m/s)	-0.019
- Vertical (m/s)	0.000
Heading	Known
- Course Over Ground (COG) (deg)	85.67
- COG Quality RMS (95%) (deg)	1.781
Attitude	Known
- Yaw/Azimuth (deg)	85.676
- Yaw Quality RMS (95%) (deg)	1
Acceleration	Known
- Easting (m/s/s)	-0.025
- Northing (m/s/s)	-0.408
- Vertical (m/s/s)	0.000
- Quality RMS (95%) (m/s/s)	4.408271
Time	Known
- Clock Offset (m)	0.008
- Clock Drift (m/s)	0.005
- Time Quality RMS (95%) (ns)	< 1
- IODT	34
Number of LocataLites (Signals)	
- Known in LocataNet	5 (20)
- Tracked	4 (16)
- Used in Solution	4 (16)
Signals Used in Solution	11(ABCD), 12(ABCD), 13(ABCD), 14(ABCD)

TimeLoc Bracing Status	
LocataLite ID 14 DEFIS-14-Indoor5	
Message Time 2022/03/24 13:46:52.140 (LocataNet internal time) : TimeLoc	
- Meas Sync This Device's measurements are aligned to the LocataNet second boundary	

LocataLite ID	14
LocataNet ID	1
LocataLite Role	Master
Dual Master Status	Active Alternate Master
TimeLoc State	Master Locked - 163
TimeLoc Bracing	Enabled
Tx Freq Offset (ppb)	106.964

TimeLoc Bracing Status

LocataLite ID 11 DEFIS-11-Indoor2

Message Time 2022/03/24 13:46:47.219 (LocataNet internal time) : TimeLoc
 - Meas Sync This Device's measurements are aligned to the LocataNet second boundary

```

LocataLite ID          11
LocataNet ID           1
LocataLite Role        Slave
LocataLite Tier        2
TimeLoc State          TimeLoc'd - 190
TimeLoc Quality         Excellent
TimeLoc Bracing        Enabled
TimeLoc Local Signal   11B
TimeLoc Ref Signal     14B
Tx Freq Offset (ppb)   102.445
Tx Freq Offset Filtered (ppb) 102.444
Tx Freq Offset Filtered Lagged (ppb) 102.445
ICP Diff Raw (cycles)  0.002
ICP Diff variation (cycles) 0.023
ICP Diff stdev (cycles) 0.004
TimeLoc ICP filtered (cycles) 0.000
Bracing LocataLite Count 1
EKF Input Measurement Count 4
EKF Valid Measurement Count 4
EKF Iteration Count    5690883
EKF Prediction Count   0
EKF Phase Quality (95%) (cycles) 0.004
EKF Phase Error (cycles) 0.002
EKF Freq Error (Hz)    0.007
EKF P[2][2]            0.000003946, 0.000002371, 0.000002371, 0.000033090
EKF Pred Phase Quality (95%) (cycles) 0.005
EKF Pred Phase Error (cycles) 0.002
EKF Pred Freq Error (Hz) 0.006
EKF Pred P[2][2]      0.000005054, 0.000003037, 0.000003037, 0.000033489
EKF Abs Freq Offset (ppb) 102.443
  
```

LocataLite Info

```

LocataLite ID          11          10          14
Rank                   0          255         1
TimeLoc Hops to Master 1          0          0
Usable Signal Count    2          0          4
ICP Difference Average (cycles) -0.005    0.000     0.001
ICP Difference Spread (cycles) 0.010    0.000     0.143
  
```

6.3.3 LocataLite 10 - Returned to Service

LocataLite 10's web page indicated that it was now operating as a TimeLoc Slave device with LocataLite 14 as its TimeLoc Reference.

LocataLite 14's web page indicated that it was still operating as the Active Alternate Master.

The Rover's web page continued to indicate a centimetre level solution but now using signals from all available LocataLites, including 10.

Web pages for LocataLites 11, 12, and 13 indicated TimeLoc Bracing using signals from both LocataLite 10 and 14.

The following are web page screen shots from the Primary Master (LocataLite 10), Secondary Master (LocataLite 14), and the Rover.

```

TimeLoc Bracing Status
-----
LocataLite ID 10  DEFIS-10-Indoor1

Message Time                2022/03/24 13:51:17.660 (LocataNet internal time) : TimeLoc
- Meas Sync                 This Device's measurements are aligned to the LocataNet second boundary

-----
LocataLite ID                10
LocataNet ID                 1
LocataLite Role              Slave
Dual Master Status           Master (Not Yet Ready)
TimeLoc State                 TimeLoc'd - 190
TimeLoc Quality               Excellent
TimeLoc Bracing              Enabled
TimeLoc Local Signal         10B
TimeLoc Ref Signal           14B
Tx Freq Offset (ppb)         -0.466
Tx Freq Offset Filtered (ppb) -0.408
Tx Freq Offset Filtered Lagged (ppb) -0.400
ICP Diff Raw (cycles)        0.002
ICP Diff variation (cycles)   0.015
ICP Diff stdev (cycles)      0.003
TimeLoc ICP filtered (cycles) 0.000
Bracing LocataLite Count     1
EKF Input Measurement Count   4
EKF Valid Measurement Count   4
EKF Iteration Count           2017
EKF Prediction Count          0
EKF Phase Quality (95%) (cycles) 0.004
EKF Phase Error (cycles)      0.002
EKF Freq Error (Hz)           -0.063
EKF P[2][2]                  0.000003946, 0.000002371, 0.000002371, 0.000033089
EKF Pred Phase Quality (95%) (cycles) 0.005
EKF Pred Phase Error (cycles) 0.000
EKF Pred Freq Error (Hz)      0.006
EKF Pred P[2][2]              0.000005054, 0.000003037, 0.000003037, 0.000033488
EKF Abs Freq Offset (ppb)     -0.460

```

```

TimeLoc Bracing Status
-----
LocataLite ID 14  DEFIS-14-Indoor5

Message Time                2022/03/24 13:51:59.920 (LocataNet internal time) : TimeLoc
- Meas Sync                 This Device's measurements are aligned to the LocataNet second boundary

-----
LocataLite ID                14
LocataNet ID                 1
LocataLite Role              Master
Dual Master Status           Active Alternate Master
TimeLoc State                 Master Locked - 163
TimeLoc Bracing              Enabled
Tx Freq Offset (ppb)         106.964

```

Nav Solution (Ext)

Rover SN21008

Solution Time 2022/03/24 13:52:03.400000007 (LocataNet internal time) : Navigation Solution
 - Meas Sync This Device's measurements are aligned to the LocataNet second boundary

Solution Validity	Valid solution computed
Position	Position centimeter
- Latitude (deg)	45.812630376
- Longitude (deg)	8.628993244
- Height (m)	261.880
- ECEF XYZ (m)	4403049.395, 668177.814, 4550943.874
- Position Quality RMS (95%) (m)	0.024
Velocity	Known
- Speed Over Ground (SOG) (km/hr)	0.042
- Speed Over Ground (SOG) (m/s)	0.012
- SOG Quality RMS (95%) (m/s)	0.401
- Easting (m/s)	-0.011
- Northing (m/s)	0.004
- Vertical (m/s)	0.000
Heading	Known
- Course Over Ground (COG) (deg)	83.95
- COG Quality RMS (95%) (deg)	1.336
Attitude	Known
- Yaw/Azimuth (deg)	83.952
- Yaw Quality RMS (95%) (deg)	1
Acceleration	Known
- Easting (m/s/s)	-0.170
- Northing (m/s/s)	-0.018
- Vertical (m/s/s)	0.000
- Quality RMS (95%) (m/s/s)	4.355138
Time	Known
- Clock Offset (m)	0.005
- Clock Drift (m/s)	0.000
- Time Quality RMS (95%) (ns)	< 1
- IODT	50
Number of LocataLites (Signals)	
- Known in LocataNet	5 (20)
- Tracked	5 (20)
- Used in Solution	5 (20)
Signals Used in Solution	10 (ABCD), 11 (ABCD), 12 (ABCD), 13 (ABCD), 14 (ABCD)

6.3.4 LocataLite 10 - Negotiating to Take Over as Master

The following web page screen shot shows Primary Master LocataLite 10 negotiating to take over as Master from Secondary Master LocataLite 14.

```

TimeLoc Bracing Status
-----
LocataLite ID 10  DEFIS-10-Indoor1

Message Time                2022/03/24 14:02:28.500 (LocataNet internal time) : TimeLoc
- Meas Sync                 This Device's measurements are aligned to the LocataNet second boundary
-----
LocataLite ID                10
LocataNet ID                 1
LocataLite Role              Slave
Dual Master Status           Master Negotiating To Take Over
TimeLoc State                TimeLoc'd - 190
TimeLoc Quality              Excellent
TimeLoc Bracing              Enabled
TimeLoc Local Signal         10B
TimeLoc Ref Signal           14B
Tx Freq Offset (ppb)         -0.252
Tx Freq Offset Filtered (ppb) -0.280
Tx Freq Offset Filtered Lagged (ppb) -0.281
ICP Diff Raw (cycles)        -0.003
ICP Diff variation (cycles)   0.017
ICP Diff stdev (cycles)      0.003
TimeLoc ICP filtered (cycles) 0.000
Bracing LocataLite Count     1
EKF Input Measurement Count   4
EKF Valid Measurement Count   4
EKF Iteration Count           35559
EKF Prediction Count          0
EKF Phase Quality (95%) (cycles) 0.004
EKF Phase Error (cycles)      -0.003
EKF Freq Error (Hz)           0.058
EKF P[2][2]                  0.000003946, 0.000002371, 0.000002371, 0.000033089
EKF Pred Phase Quality (95%) (cycles) 0.005
EKF Pred Phase Error (cycles) -0.002
EKF Pred Freq Error (Hz)      0.006
EKF Pred P[2][2]              0.000005054, 0.000003037, 0.000003037, 0.000033488
EKF Abs Freq Offset (ppb)     -0.279

```

6.3.5 LocataLite 10 - About to Take Over as the Master

The following web page screen shot shows Primary Master LocataLite 10 about to take over as Master from Secondary Master LocataLite 14.

```

TimeLoc Bracing Status
-----
LocataLite ID 10  DEFIS-10-Indoor1

Message Time 2022/03/24 14:10:38.719 (LocataNet internal time) : TimeLoc
- Meas Sync  This Device's measurements are aligned to the LocataNet second boundary

-----
LocataLite ID 10
LocataNet ID 1
LocataLite Role Slave
Dual Master Status Master Imminently Taking Control
TimeLoc State TimeLoc'd - 190
TimeLoc Quality Excellent
TimeLoc Bracing Enabled
TimeLoc Local Signal 10B
TimeLoc Ref Signal 14B
Tx Freq Offset (ppb) -0.252
Tx Freq Offset Filtered (ppb) -0.255
Tx Freq Offset Filtered Lagged (ppb) -0.260
ICP Diff Raw (cycles) 0.000
ICP Diff variation (cycles) 0.010
ICP Diff stdev (cycles) 0.002
TimeLoc ICP filtered (cycles) 0.000
Bracing LocataLite Count 1
EKF Input Measurement Count 4
EKF Valid Measurement Count 4
EKF Iteration Count 60070
EKF Prediction Count 0
EKF Phase Quality (95%) (cycles) 0.004
EKF Phase Error (cycles) 0.000
EKF Freq Error (Hz) 0.005
EKF P[2][2] 0.000004346, 0.000002597, 0.000002597, 0.000033226
EKF Pred Phase Quality (95%) (cycles) 0.005
EKF Pred Phase Error (cycles) 0.000
EKF Pred Freq Error (Hz) 0.006
EKF Pred P[2][2] 0.000005462, 0.000003266, 0.000003266, 0.000033625
EKF Abs Freq Offset (ppb) -0.248

```

6.3.6 LocataLite 10 - Takes Over as the Master

The following web page screen shots show a return to normal operation with LocataLite 10 as the Primary Master and LocataLite 14 as the Secondary (Alternate) Master.

```

TimeLoc Bracing Status
-----
LocataLite ID 10  DEFIS-10-Indoor1

Message Time                2022/03/24 14:20:24.879 (LocataNet internal time) : TimeLoc
- Meas Sync                This Device's measurements are aligned to the LocataNet second boundary

-----
LocataLite ID              10
LocataNet ID               1
LocataLite Role            Master
TimeLoc State              Master Locked - 163
TimeLoc Bracing            Enabled
Tx Freq Offset (ppb)       0.000
  
```

```

TimeLoc Bracing Status
-----
LocataLite ID 14  DEFIS-14-Indoor5

Message Time                2022/03/24 14:20:33.419 (LocataNet internal time) : TimeLoc
- Meas Sync                This Device's measurements are aligned to the LocataNet second boundary

-----
LocataLite ID              14
LocataNet ID               1
LocataLite Role            Slave
Dual Master Status         Alternate Master (Ready To Take Over)
TimeLoc State              TimeLoc'd - 190
TimeLoc Quality            Excellent
TimeLoc Bracing            Enabled
TimeLoc Local Signal       14B
TimeLoc Ref Signal         10B
Tx Freq Offset (ppb)       107.194
Tx Freq Offset Filtered (ppb) 107.184
Tx Freq Offset Filtered Lagged (ppb) 107.187
ICP Diff Raw (cycles)      -0.003
ICP Diff variation (cycles) 0.017
ICP Diff stdev (cycles)    0.003
TimeLoc ICP filtered (cycles) 0.000
Bracing LocataLite Count   1
EKF Input Measurement Count 2
EKF Valid Measurement Count 2
EKF Iteration Count        1670
EKF Prediction Count       0
EKF Phase Quality (95%) (cycles) 0.005
EKF Phase Error (cycles)   -0.003
EKF Freq Error (Hz)        0.004
EKF P[2][2]                0.000005891, 0.000003470, 0.000003470, 0.000033746
EKF Pred Phase Quality (95%) (cycles) 0.005
EKF Pred Phase Error (cycles) -0.003
EKF Pred Freq Error (Hz)   0.006
EKF Pred P[2][2]          0.000007043, 0.000004149, 0.000004149, 0.000034147
EKF Abs Freq Offset (ppb)  107.181
  
```

7 Acknowledgements

Locata gratefully recognizes the fact that these two European Commission contracts – one for Timing and one for Positioning – gave Locata an exceptional opportunity to publicly showcase our new technology developments to the industry, and the world at large. Locata was honoured as the only company to receive two contracts out of the seven the EC had on offer. Locata was highly motivated to participate in these trials because we knew all testing would be independently conducted by the EC’s Joint Research Centre subject-matter experts. This ensured that all reported results (such as those documented above) carry the underlying authentication of this globally-recognized Research Centre.

Locata also thanks the European Commission for the tremendous support the JRC team provided our engineers during the JRC test campaign. JRC staff provided invaluable assistance, assisting with the set up and oversight of these tests over a long period – both on and off the JRC campus.