



# JRC SCIENCE FOR POLICY REPORT

## Assessing Alternative Positioning, Navigation, and Timing Technologies for Potential Deployment in the EU

2023



Joint  
Research  
Centre

This publication is a Science for Policy report by the Joint Research Centre (JRC), the European Commission's science and knowledge service. It aims to provide evidence-based scientific support to the European policymaking process. The contents of this publication do not necessarily reflect the position or opinion of the European Commission. Neither the European Commission nor any person acting on behalf of the Commission is responsible for the use that might be made of this publication. For information on the methodology and quality underlying the data used in this publication for which the source is neither Eurostat nor other Commission services, users should contact the referenced source. The designations employed and the presentation of material on the maps do not imply the expression of any opinion whatsoever on the part of the European Union concerning the legal status of any country, territory, city or area or of its authorities, or concerning the delimitation of its frontiers or boundaries.

#### Contact information

Name: Lukasz Bonenberg

Address: European Commission, Joint Research Centre (JRC), Via Enrico Fermi 2749, Ispra 21027 (VA), Italy

Email: Lukasz.Bonenberg@ec.europa.eu

Tel.: +39 0332 789 9014

#### EU Science Hub

<https://joint-research-centre.ec.europa.eu>

JRC132737

EUR 31450 EN

EN PDF

ISBN 978-92-68-01163-8

ISSN 1831-9424

doi:10.2760/596229

KJ-NA-31-450-EN-N

Luxembourg: Publications Office of the European Union, 2023

© European Union, 2023



The reuse policy of the European Commission is implemented by the Commission Decision 2011/833/EU of 12 December 2011 on the reuse of Commission documents (OJ L 330, 14.12.2011, p. 39). Except otherwise noted, the reuse of this document is authorised under the Creative Commons Attribution 4.0 International (CC BY 4.0) licence (<https://creativecommons.org/licenses/by/4.0/>). This means that reuse is allowed provided appropriate credit is given and any changes are indicated. For any use or reproduction of photos or other material that is not owned by the EU, permission must be sought directly from the copyright holders.

All content © European Union, 2023 unless otherwise mentioned within the document.

How to cite this report: Bonenberg, L., Motella, B., Fortuny-Guasch, J., *Assessing Alternative Positioning, Navigation, and Timing Technologies for Potential Deployment in the EU*, Publications Office of the European Union, Luxembourg, 2023, doi:10.2760/596229, JRC132737

## Table of Contents

Abstract .....	1
Acknowledgements.....	2
Executive Summary.....	3
1 Introduction .....	4
1.1 Scope of the Document.....	4
1.2 Applicable Documents .....	4
1.3 Reference Documents.....	5
1.4 Acronyms.....	5
2 Background .....	7
2.1 Rationale behind A-PNT Demonstrations .....	7
2.2 A-PNT Demonstrations and Initiatives .....	8
2.2.1 FY18 NDAA Section 1606 Complementary PNT Demonstration .....	8
2.2.2 The UK National Timing Centre Programme.....	9
2.2.3 Relevant EU Policy Actions.....	9
3 Assessment of the A-PNT Demonstration Platforms.....	10
3.1 Summary .....	10
3.2 Objectives and Assessed Key Performance Indicators (KPI).....	11
3.3 Platform Providers Awarded.....	13
3.4 Demonstrations Time Schedule .....	13
4 JRC's Reference Systems and Test Infrastructure .....	15
4.1 JRC Site Description.....	15
4.2 Timing Reference .....	16
4.2.1 UTC(IT) Calibration of the JRC Time Rig .....	18
4.3 Surveying of the A-PNT Installation Sites.....	18
4.4 Analytical Methods .....	22
4.4.1 Assessment of the Timing Accuracy.....	22
4.4.2 Assessment of the Positioning Accuracy .....	22
5 Performance Evaluation Results.....	24
5.1 OPNT .....	26
5.1.1 Key Performance Indicators (KPI's).....	26
5.1.2 A-PNT Technology Under Test .....	28
5.1.3 Time Transfer Fibre .....	29

5.1.4	Time Transfer OTA Outdoor .....	31
5.1.5	Resilience .....	33
5.2	Seven Solutions SL (Safran Group) .....	34
5.2.1	Key Performance Indicators (KPI's) .....	35
5.2.2	A-PNT Technology under Test .....	35
5.2.3	Time Generation .....	36
5.2.4	Time Transfer Fibre .....	37
5.2.5	Resilience .....	37
5.3	SCPTIME .....	38
5.3.1	A-PNT Technology under Test .....	38
5.3.2	Time Transfer Networks .....	38
5.3.3	Resilience .....	39
5.4	GMV Aerospace and Defence SAU .....	41
5.4.1	Key Performance Indicators (KPI's) .....	42
5.4.2	A-PNT Technology under Test Setup .....	42
5.4.3	Time Generation .....	43
5.4.4	Time Transfer Fibre .....	43
5.4.5	Time Transfer Networks .....	43
5.4.6	Resilience .....	44
5.5	Satelles Inc. ....	45
5.5.1	Key Performance Indicators (KPI's) .....	45
5.5.2	A-PNT Technology under Test .....	45
5.5.3	Time Generation and OTA time transfer .....	47
5.5.4	Time Transfer OTA Indoor .....	48
5.5.5	Static Outdoor Positioning .....	49
5.5.6	Static Indoor Positioning .....	50
5.5.7	Resilience .....	50
5.6	Locata Corporation Pty Ltd .....	52
5.6.1	Key Performance Indicators (KPI's) .....	52
5.6.2	A-PNT Technology under Test .....	53
5.6.3	Timing Setup .....	53
5.6.4	Positioning Setup .....	55



5.6.5	Time Generation .....	57
5.6.6	Time Transfer Reporting .....	57
5.6.7	Time Transfer Fibre .....	57
5.6.8	Time Transfer Networks.....	57
5.6.9	Time Transfer OTA Outdoor.....	58
5.6.10	Time Transfer OTA Indoor.....	59
5.6.11	Static Outdoor Positioning .....	59
5.6.12	Static Indoor Positioning .....	60
5.6.13	Kinematic Outdoor Positioning.....	61
5.6.14	Kinematic Indoor Positioning.....	63
5.6.15	Resilience .....	66
5.7	NextNav LLC .....	67
5.7.1	Key Performance Indicators.....	67
5.7.2	A-PNT Technology under Test.....	68
5.7.3	Time Generation .....	69
5.7.4	Time Transfer OTA Indoor.....	70
5.7.5	Static Outdoor Positioning .....	71
5.7.6	Static Indoor Positioning .....	72
5.7.7	Kinematic Outdoor Positioning.....	72
5.7.8	Kinematic Indoor Positioning.....	73
5.7.9	Resilience .....	73
6	Test Campaign Conclusions .....	75
7	Main Recommendations.....	77

## **Abstract**

Today, many EU critical infrastructures, such as energy supply networks, transport infrastructures, telecommunications, and financial networks, have a strong reliance on Global Satellite Navigation Systems (GNSS). Since these infrastructures have become primary users of Positioning, Navigation and Timing (PNT) services, the availability of backups or Alternative PNT (A-PNT) infrastructures should be considered as a priority to mitigate the impact of a potential disruption of GNSS.

This report presents the results of a test campaign, conducted at the European Commission (EC) Joint Research Centre (JRC), Ispra. It was aimed at assessing the performance of A-PNT demonstration platforms. This testing and performance evaluation assessment activity were conducted, in the framework of a Call for Tender launched by the Directorate General for Defence Industry and Space (DEFIS) of the EC.

Over eight months of testing activities, the selected A-PNT platforms were evaluated at the JRC premises, and in a few cases, also at other locations, as agreed with the A-PNT platform providers. Such demonstrations showcased precise and robust timing and positioning services, in indoor and outdoor environments. During the evaluation of the A-PNT platforms, time transfer technologies over different means were demonstrated, including over the air (OTA), fiber, and wired channels. The results of the test campaign showed that all A-PNT platforms under evaluation demonstrated performances in compliance with the requirements set.

## Acknowledgements

The testing campaign assessing the performance of the Alternative Positioning, Navigation, and Timing (A-PNT) demonstration platforms is the result of a collaborative effort and support of many teams.

First of all, the authors want to thank the teams of the companies who were on-site during the installations of demonstration platforms and the execution of the tests. The installations and the tests took place during the Covid pandemic and, therefore, we thank them for their understanding and respect of the restrictions and measures adopted in the JRC.

We are thankful to our colleagues in the Satellite Navigation Unit of the European Commission Directorate General Defence Industry and Space, for the management and coordination of the Call for Tender, and the close follow up of the A-PNT demonstrations.

The authors acknowledge the collaboration with the Italian's National Metrology Institute INRIM, for the support given with the calibration of the JRC's timing rig to get it aligned with their UTC time scale.

We thank the teams in the Directorate General of Electronic Communications, Radio Broadcasting and Postal Services, in the Italian Ministry of Economic Development, for granting the temporary license to use the 920-927 MHz frequency band, and those in the Italian Railways Network and Illiad companies, for having facilitated the trials and having allowed the activation of the radio beacons in the Campus of the JRC in February 2022.

Finally, the authors wish to thank the following JRC services for the support given to the installation and deployment of the A-PNT demonstration platforms:

- The JRC Corporate Network Services team for the assistance setting up the VLAN containers needed to provide remote access to the A-PNT platforms.
- The JRC Customs, Reception and Shipment of Goods offices for the assistance dealing with the import-export formalities that allowed the timely arrival of all the A-PNT goods.
- The team in the JRC Safety and Security of Buildings Unit for having facilitated and supported the installation of one of the A-PNT demonstrators in the ELSA laboratory.
- The team in the JRC Infrastructure Unit for the assistance in the installation of the radio beacons of the A-PNT demonstrators on the roof of the buildings.
- The team in the JRC Clean Air and Climate Unit for having facilitated the installation of the radio beacons on the Atmospheric Observatory Tower.
- The colleagues in the JRC Technologies for Space, Security and Connectivity Unit, for the support given in the installations in the JRC Campus and, in particular, on the Atmospheric Observatory Tower, and for the organization of the A-PNT Demo Day event in May 2022.
- The A-PNT testing campaign subject of this report benefited from the JRC Living Labs framework, which enables the access to the JRC Campus to carry out demonstrations in real-life conditions. The authors are thankful to this facilitation.

## Executive Summary

Our society and economy are crucially dependent on positioning, navigation, and timing (PNT) services provided by Global Satellite Navigation Systems (GNSS), such as the European Galileo and the USA Global Positioning System (GPS). Only for the EU, the total economic benefits of GNSS, in the 1999-2027 period, were estimated at €2 trillion alongside the creation of more than 100,000 highly skilled jobs. Furthermore, Galileo and EGNOS have a tangible impact on many EU policy domains, such as the economy (e.g., transport, mobility, industry), the EU Green Deal (e.g., agriculture, fisheries, environment), or security and defence (e.g., emergency and crisis management, the EU strategic autonomy and independence).

While the benefits and ubiquitousness of GNSS are evident and indisputable, one must be aware of the potential disruptions, which could be triggered maliciously with a jamming or spoofing attack or by a GNSS system infrastructure malfunction. Today, many EU critical infrastructures, such as energy supply networks, transport infrastructures, telecommunications, and financial networks, have a strong reliance on GNSS. Since these infrastructures have become primary users of PNT services, the availability of backups or alternative sources of PNT services (A-PNT) should be considered as a priority.

There is also a possible use scenario with these A-PNT services being permanently active to increase the robustness and even augment classical GNSS. Two relevant policy initiatives of the EC in this context are the Directives on *the resilience of critical entities (CER Directive)* and *cybersecurity (NIS2 Directive)*, which mandate Member States to identify the critical infrastructures and undertake measures to strengthen their resilience against physical and cyber attacks. Equally important is the European Union's current policy objective of Strategic autonomy, with the Strategic Compass for Security and Defence requesting better cyber defence policy, investment in capabilities and innovative technologies and co-operation with partners.

In the framework of a call for tender (CfT) launched by the Directorate General for Defence Industry and Space (DEFIS) of the European Commission (EC) in December 2020, a performance assessment campaign on a total of seven state-of-the-art A-PNT demonstration platforms has been conducted, with the scientific and technical lead of the EC Joint Research Centre (JRC). The main scope of the tender was to assess the performance of the A-PNT technology demonstrators capable of delivering accurate and robust positioning, and/or timing services, independently from GNSS. Additionally, and as an option, the capability to provide PNT services in environments where GNSS cannot be delivered, was asked to be demonstrated.

The test campaign objective was to assess the conformance of each A-PNT demonstration platform against the requirements set. Seven A-PNT platforms have been tested at the JRC premises and in a few additional cases, at other test sites suggested by the A-PNT platform provider. Starting in September 2021, almost eight months of testing have been completed, with the A-PNT platforms demonstrating precise and robust timing provision and transfer and some demonstrating positioning services, both indoor and outdoor.

This report summarises the main results of the tests. It includes the presentation of the minimum technical requirements, the definition of the test plan, and describes the setup of the testing facilities for the experiments. An important outcome of this test campaign is the demonstration that the A-PNT platforms under evaluation can deliver positioning, and/or timing information independently from GNSS.

# 1 Introduction

## 1.1 Scope of the Document

The scope of the report is to describe the tests campaign, focused on the assessment of the performance of Alternative Position, Navigation and Timing (A-PNT) demonstration platforms, independent from Global Navigation Satellite Systems (GNSS). This activity was conducted at the [European Commission \(EC\) Joint Research Centre \(JRC\)](#), in its Ispra Site, in the framework of the call for tender (CfT) No DEFIS/2020/OP/0007 [\[RD. 1\]](#), launched by the Directorate General for Defence Industry and Space (DEFIS) of the EC.

The document describes testing activities, the definition of the testing protocols, the presentation of the minimum technical requirements, the most relevant outcomes of the performance assessment on every individual A-PNT platform, and the main conclusions and highlights of the whole test campaign.

After this Introduction, this document is structured as follows:

- Section 2 describes the background of the A-PNT call and its rationale;
- Section 3 describes project objectives, along with the project time schedule;
- Section 4 deals with the infrastructures used for the tests campaign and the metrics used to assess the performance of the A-PNT platforms;
- Section 5 presents the main results of the performance assessment of each individual A-PNT platform;
- Section 6 draws the conclusions and the recommendations for future initiatives.

## 1.2 Applicable Documents

This section lists all applicable and reference documents relevant for the scope of this report. It also contains a list of the acronyms used throughout the document and their definition.

#	Issue	Title
[AD. 1]	D210 1.6	Technical Report and Test Plan OPNT
[AD. 2]	D210 2.1	Technical Report Seven Solutions SL
[AD. 3]	D210 2.1	Technical Report SCPTIME
[AD. 4]	D210 2.0	Technical Report GMV Aerospace and Defence SAU
[AD. 5]	D210 1.6	Technical Report Satelles Inc
[AD. 6]	D210 1.5	Technical Report Locata Corporation Pty Ltd
[AD. 7]	D210	Technical Report NextNav

All the applicable documents and this report are available online [here](#).



### 1.3 Reference Documents

#	Title
[RD. 1]	'Services - 506573-2020 - TED Tenders Electronic Daily', 7 December 2022. <a href="https://ted.europa.eu/udl?uri=TED:NOTICE:506573-2020:DATA:EN:HTML">https://ted.europa.eu/udl?uri=TED:NOTICE:506573-2020:DATA:EN:HTML</a> .
[RD. 2]	European Union Agency for the Space Programme. EUSPA EO and GNSS Market Report.2022 / Issue 1 . LU: Publications Office, 2022. <a href="https://data.europa.eu/doi/10.2878/94903">https://data.europa.eu/doi/10.2878/94903</a> .
[RD. 3]	O'Connor, Alan C., Michael P. Gallaher, Kyle Brannon Clark-Sutton, Daniel Lapidus, Zack Oliver, Troy J. Scott, Dallas Wayne Wood, and Elizabeth G. Brown. 'Economic Benefits of the Global Positioning System (GPS)', 31 May 2019. <a href="https://www.rti.org/publication/economic-benefits-global-positioning-system-gps">https://www.rti.org/publication/economic-benefits-global-positioning-system-gps</a> .
[RD. 4]	London Economics. 'The Economic Impact on the UK of a Disruption to GNSS', June 2017. <a href="https://londoneconomics.co.uk/blog/publication/economic-impact-uk-disruption-gnss/">https://londoneconomics.co.uk/blog/publication/economic-impact-uk-disruption-gnss/</a> .
[RD. 5]	Mason, Richard, James Bonomo, Tim Conley, Ryan Consaul, David R. Frelinger, David A. Galvan, Dahlia Anne Goldfeld, et al. 'Analyzing a More Resilient National Positioning, Navigation, and Timing Capability'. RAND Corporation, 17 May 2021. <a href="https://www.rand.org/pubs/research_reports/RR2970.html">https://www.rand.org/pubs/research_reports/RR2970.html</a> .
[RD. 6]	Bartock, Michael, Suzanne Lightman, Ya-Shian Li-Baboud, James McCarthy, Karen Reczek, Joseph Brule, Doug Northrip, Arthur Scholz, and Theresa Suloway. 'Foundational PNT Profile: Applying the Cybersecurity Framework for the Responsible Use of Positioning, Navigation, and Timing (PNT) Services'. National Institute of Standards and Technology, 29 June 2022. <a href="https://doi.org/10.6028/NIST.IR.8323r1.ipd">https://doi.org/10.6028/NIST.IR.8323r1.ipd</a> .
[RD. 7]	GOV.UK. 'Satellite-Derived Time and Position: Blackett Review'. Accessed 2 February 2023. <a href="https://www.gov.uk/government/publications/satellite-derived-time-and-position-blackett-review">https://www.gov.uk/government/publications/satellite-derived-time-and-position-blackett-review</a> .
[RD. 8]	Wildemeersch, Matthias, Fortuny-Guasch, Joaquim. 'Radio Frequency Interference Impact Assessment on Global Navigation Satellite Systems'. JRC Publications Repository, 31 March 2010. <a href="https://doi.org/10.2788/6033">https://doi.org/10.2788/6033</a> .
[RD. 9]	Hansen, Andrew, Stephen Mackey, Hadi Wassaf, Vaibhav Shah, Eric Wallischeck, Christopher Scarpone, Michael Barzach, and Elliott Baskerville. 'Complementary PNT and GPS Backup Technologies Demonstration Report Sections 1 through 10', n.d., 457.
[RD. 10]	Koelemeij, Jeroen C. J., Han Dun, Cherif E. V. Diouf, Erik F. Dierikx, Gerard J. M. Janssen, and Christian C. J. M. Tiberius. 'A Hybrid Optical–Wireless Network for Decimetre-Level Terrestrial Positioning'. Nature 611, no. 7936 (November 2022): 473–78. <a href="https://doi.org/10.1038/s41586-022-05315-7">https://doi.org/10.1038/s41586-022-05315-7</a> .

### 1.4 Acronyms

A-PNT	Alternative PNT
CDF	Cumulative Distribution Function
CEP	Circular error probable
CFI	Customer Furnisher items
CfT	Call for Tender
DEFIS	Directorate General for Defence, Industry and Space
DOT	US Department of Transport
EC	European Commission
EMSL	European Microwave Signature Laboratory

<b>ERNP</b>	European Radio Navigation Plan
<b>ETSI</b>	European Telecommunications Standards Institute
<b>EUSPA</b>	EU Agency for the Space Programme
<b>FAA</b>	Federal Aviation Administration
<b>GDP</b>	Gross Domestic Product
<b>GNSS</b>	Global Navigation Satellite System
<b>GPS</b>	Global Positioning System
<b>HAS</b>	Galileo High Accuracy Service
<b>HNSE</b>	Horizontal Navigation Standard Error
<b>INRIM</b>	Italian National Institute of Metrology Research
<b>JRC</b>	European Commission Joint Research Centre
<b>KPI</b>	Key Performance Indicator
<b>LEO</b>	Low Earth Orbit
<b>LTE</b>	Long-Term Evolution
<b>MS</b>	Member State
<b>MTIE</b>	Maximum Time Interval Error
<b>OSNMA</b>	Galileo Open Service Navigation Message Authentication
<b>PNT</b>	Positioning, Navigation and Timing
<b>PUT</b>	Platform Under Test
<b>RETS</b>	Resilience Enhanced Time Service
<b>RFI</b>	Radio-frequency Interference
<b>TIC</b>	Timing Interval Counter
<b>TRL</b>	Technology Readiness Level
<b>UTC</b>	Coordinated Universal Time
<b>WAAS</b>	Wide Area Augmentation System

## 2 Background

### 2.1 Rationale behind A-PNT Demonstrations

Today, GNSS services are the backbone of PNT services and its central role is bound to increase in the future with the advent of a new wave of services and business-like car-sharing, smart logistics, autonomous vehicles-ships-aircrafts, geo-localising applications, precision agriculture and others. A recent study of the EU Agency for the Space Programme (EUSPA) estimates that, over the period of 1999-2027, the socio-economic benefits provided by GNSS reached €2 trillion in European territory (defined as the EU27 plus the UK, Norway, and Switzerland). In addition to this, over the same period more than 100,000 highly skilled jobs, attributable to GNSS industry were created.

The European Radio Navigation Plan (ERNP) list global challenges such as the digital revolution, climate change and global pandemics that our economy and society is facing today. As pointed out in the 2022 edition of the Technology Report issued by EUSPA [RD. 2], PNT and GNSS play a vital role in providing innovative solutions addressing those challenges.

GNSS jamming incidents reports increase in number and frequency, most of them caused by so-called ‘privacy protection devices’ (illegal in most countries). GNSS spoofing incidents are less frequently reported, but they are also increasing in number. Recent studies in the US [RD. 3] and the UK [RD. 4] have estimated economic losses of around EUR 1 billion per day of GNSS unavailability, though [RD.4] argues that this value might be too large. The US [RD. 6], [RD. 5], UK [RD. 7] and other nations are investigating and have plans to deliver “resilient” PNT services or GNSS back-up services in their territories. In addition, PNT services and notably its timing capabilities are exploited by critical infrastructures which are strategic for the functioning of the modern society, such as telecom, energy, finance, and transport (e.g., road, maritime, and aviation).

The overall discussion<sup>1</sup>, clearly demonstrate a raising concern and public perception of the reported issue. GNSS services response to these threats by including authentication capabilities as a necessary building block of the overall application security. Yet, due to the major role of GNSS in the economy and society, and the importance of the risk of the disruption or denial of GNSS services, there is a need of alternative PNT capacity, without common modes of failure with GNSS [RD. 8]. Hence, the sensitivity and timing of the reported test campaign should not be understated.

---

<sup>1</sup> To list just a few non-governmental sources: *The Economic Impact on the UK of a Disruption to GNSS*, London Economics, 2017, *GPS Is Easy to Hack, and the U.S. Has No Backup*, Scientific American, Dec 2019, and *Satellite-navigation systems such as GPS are at risk of jamming*, Economist, May 2021.

## 2.2 A-PNT Demonstrations and Initiatives

The Call for Tender (CfT) DEFIS/2020/OP/0007 [\[RD. 1\]](#) was open to WTO Government Procurement Agreement (GPA) countries, with the objective to assess the performance of the mature technologies that could:

- Deliver positioning, and/or timing information independently from GNSS;
- Act as the backup in the event of a GNSS disruption;
- (If possible) extend PNT provision to the environments where GNSS cannot be delivered.

Such back-up and complementary technologies are further called in this project “alternative PNT (A-PNT) services” which together with GNSS constitute “resilient PNT services”. The objective of the CfT was to address three major elements:

- The testing of the proposed technologies;
- A Technical Report with the technology description and including Technology Readiness Level (TRL) justification, the possible scalability, the supported environments, any required licences, etc.
- An Implementation Report of the technology/service, including cost and schedule elements, if the technology were to be deployed in the EU.

This document focuses on the first two elements, identifying, assessing, and describing possible backup technologies.

Some relevant governmental initiatives aimed at enhancing the resilience of PNT services have been carried out in the USA, in the UK, and in the EU. A summary of the scope and objectives of these various activities is given next.

### 2.2.1 FY18 NDAA Section 1606 Complementary PNT Demonstration

The U.S. Department of Transportation (DOT) is the focal point for PNT policy, which in the USA has centered primarily on GPS, used across the country in all modes of transportation. The Federal Aviation Administration (FAA) is responsible for supporting all aviation users of GPS and of FAA’s associated Wide Area Augmentation System (WAAS), which is a real-time overlay to GPS providing safety-of-life navigation based on the open signals broadcast by GPS. These and other economic activities in transportation, among other civil sectors, are dependent on space-based PNT for maintaining normal operations both within and outside U.S. territory.

The USA have conducted a trial of the A-PNT technologies in 2020, following [the National Timing Resilience and Security Act of 2018](#), which required timing system to back up GPS. Following this in Feb 2020 the [US Presidential Order](#) established the drafting of PNT Profiles for critical and non-critical users, that will be applied in federal contracts.

Under the management of the US DOT, a series of [RFI demonstrations](#) have been carried out in May 2020 with the 11 companies that were selected. Those demonstrations were carried out at [Joint Base Cape Cod](#) and [NASA Langley Research Center](#). Those included PNT systems based on networks of sparse radio beacons, a Low Earth Orbit (LEO) satellite constellation providing a timing service on the ground, eLORAN, fibre optic networks with time and frequency transfer, and navigation using map matching.

A comprehensive report was published early 2021 [RD. 9], and the results were presented at the Complementary PNT Industry Roundtable, August 4, 2022. Follow up activities can be found at <https://www.transportation.gov/pnt/gps-backupcomplementary-pnt-demonstration>.

### **2.2.2 The UK National Timing Centre Programme**

In 2020, the UK Research and Innovation Council announced the Strategic Priorities Fund, which includes a 5 year programme providing £36 million for assured Time and Frequency for the UK. This effort is led by NPL's [the UK National Timing Centre](#) and focuses on three lines:

- Develop Resilient Enhanced Time Scale Infrastructure, that creates mesh of a resilient distributed atomic clocks timing infrastructure, independent from GNSS, through the UK;
- Funding for the UK industry via Innovate UK;
- Dedicated training for specialists, postgraduates, and apprentices.

The Centre is tasked with providing additional resilience for the country's accurate timing resilience by expanding network of time generating sites and atomic clock backups that offer UTC(k) traceable time to users. The Resilience enhanced Time Service (RETS) infrastructure, consisting of four sites and intended to be independent of the GNSS. Centre is also working with the industry with their remit of supporting multiple industries from electric networks and finance to broadcast, telecoms and aerospace.

### **2.2.3 Relevant EU Policy Actions**

The European Commission has undertaken multiple regulatory actions aimed at enhancing the resilience of PNT infrastructures and services in the EU. The main policy actions addressed to date are:

- The [EU Space Programme Regulation](#) includes a request to Member States to protect EU Space ground infrastructure to the level of National CI and also calls for stringent cybersecurity requirements for the EU Space Programmes;
- The update of the [EU Critical Infrastructures \(CI\)](#) and [Network Information Systems \(NIS\)](#) Directives will integrate further resilience requirements for several domains, including space but excluding the EU Space Programmes since already covered by EU Space Regulation;
- The publication of a Commission Staff Working Document (SWD) defining the use of EGNSS for timing and synchronization in CI is under study;
- The evolution of EU GNSS services has the enhancement of the resilience and robustness one of the main drivers. An example of this is the [Galileo OSNMA service](#), which will be declared in 2023 and will provide an authentication of navigation message. Additional services with authentication at the signal level will be introduced in the Second Generation of Galileo (G2G);
- The European Commission will release a new European Radio Navigation Plan, a reference document presenting the evolution of the landscape of PNT infrastructures in the EU with the aim to identify potential gaps and synergies in the various PNT sectoral domains.



### 3 Assessment of the A-PNT Demonstration Platforms

#### 3.1 Summary

The scientific and technical support of the EC JRC, in the framework of the call for tender No DEFIS/2020/OP/0007 [RD. 1], launched by DEFIS, focused on the demonstration activities of the technologies able to provide Alternative Position, Navigation and Timing:

The awarded providers of A-PNT platforms were tested at the JRC premises, for eight months, starting in October 2021, with the technologies demonstrating:

- Precise and robust timing provision and transfer;
- Positioning services, both indoor and outdoor, using networks of terrestrial radio beacons and LEO based signal.

The testing campaign foreseen:

- The preparation of the tests set-up, including the design of the tests, the logistics behind, the secure connectivity setting, and the shipment of goods
- The testing platforms implementation, i.e., the set-up of outdoor moving platform, indoor test area, time testing rigs in two lab and JRC Time Reference Traceability to UTC(IT). Such a calibration was conducted in cooperation with the Italian National Institute of Metrology Research (INRIM)
- The execution of the tests, both across the JRC Site and the locations outside (i.e., in Germany, Netherlands, Spain and the USA).

The JRC was in charge of preparing and running the test campaign, including reviewing the documents, managing communication and interaction with each platform provider. It was responsible for the test infrastructure within the JRC site (as described in section 4) and test protocol. The JRC Site Infrastructure Service supported the deployment of the A-PNT demonstrators in the laboratory and in various other locations in the Campus. This included the installation of radio beacons and test equipment both on the roofs of buildings and indoors, interfacing with the IT Services to get the required network connectivity, liaising with the Italian Spectrum Regulator to get the temporary licenses, install and operate the test equipment needed to assess the performance of the A-PNT demonstrators, and the logs data collection and processing using JRC's test-equipment.

Platform providers were to provide Platform Under Test (PUT), test plan, support test execution and provide the final deliverables (reports). In the case of tests conducted on other sites, participants were responsible for test infrastructure, with JRC support when possible.

The test campaign took almost eight months to complete and finalised with the *A-PNT Demo Day*, on 18<sup>th</sup> May 2022, where initial results were presented and practical demonstrations of the selected technologies were arranged. It was held as a side-event of the EU-US WG-C meeting hosted at the JRC Ispra, with EC and Industry in attendance. It covered both the technology demonstrations, presented in the morning, and a hybrid session showing the first campaign results, held in the afternoon. About 80 people attended on-site and about 90 online. The event received very positive feedbacks, both from the industry and the DEFIS itself.

### 3.2 Objectives and Assessed Key Performance Indicators (KPI)

As part of the Alternative Position, Navigation and Timing (PNT) Services tender, the main goal of the project was to analyse the technologies, which could deliver positioning, and/or timing information, independently from GNSS, to be effective backup in the event of GNSS disruption, even if it represents an unlikely situation AND if possible, to be able to provide PNT in the environments where GNSS services cannot be delivered (e.g. complementary PNT). Such back-up and complementary technologies are further called in this project “alternative PNT services” which together with GNSS constitute “resilient PNT services” shall comply with the following Key Performance Indicators (KPIs), as defined in the Tender specifications for Alternative Position, Navigation and Timing Services):

- *Can deliver positioning, and/or timing information independently from GNSS;*
- *Act as the backup in the event of a GNSS disruption or outage;*
- *Able to provide the coverage for the EU European territory including in-land waters;*
- *Resilient to GNSS failure modes and vulnerabilities (including GNSS frequency jamming and spoofing or unintentional interference);*
- *(If possible) extend PNT provision to the environments where GNSS cannot be delivered, i.e.: urban canyons, indoor, underground and underwater.*
- *Have TRL greater than 5 for position/navigation services OR greater than 6 for timing services.*
- *Provide minimum performance of the alternative PNT service for at least 1 day upon GNSS loss:*
  1. *Positioning Accuracy (Horizontal and/or Vertical 95%) < 100 m OR Timing Accuracy to UTC (3 sigma) < 1 microsec AND*
  2. *Availability > 99%*
- *If the alternative PNT service provides a timing service, traceability to UTC shall be possible.*

KPIs of the alternative PNT service was to be assessed after 1 day, 14 days and 100 days of GNSS services loss. If possible, systems should also provide position and/or time information in the environments where GNSS cannot be efficiently delivered, as for instance:

- Urban canyons,
- Indoor,
- Underground,
- Underwater,
- and if is capable to provide service for fast moving platforms, such as spacecrafts and launchers.

Description and justification on whether the proposed technology is:

- Robust to interference, including for GNSS frequencies, weak RF, strong RF,
- Encryption-ready, including for data, signal,
- Scalable to local, regional or continental scale.

This scalability of the service should notably cover:

- EU European territorial waters (50 NM from land),
- EU airspace (as a minimum, up to 20 km AGL (altitude over ground level)),
- Worldwide, including open water.

The aim is a science based, unbiased and interdependent agnostic testing able to establish strong and weak points of each proposed service, based on the published KPIs.

### 3.3 Platform Providers Awarded

Out of the nine tenders, the evaluation committee selected seven for the award.

- Contract No: DEFIS/2020/OP/007-1 OPNT
- Contract No: DEFIS/2020/OP/007-2 Seven Solutions SL
- Contract No: DEFIS/2020/OP/007-3 SCPTIME
- Contract No: DEFIS/2020/OP/007-4 GMV Aerospace and Defence SAU
- Contract No: DEFIS/2020/OP/007-5 Satelles Inc
- Contract No: DEFIS/2020/OP/007-6 Locata Corporation Pty Ltd, Timing Solutions
- Contract No: DEFIS/2020/OP/007-7 Locata Corporation Pty Ltd, Positioning Solutions

Separately, it was agreed to let participate NextNav LLC in the trials.

### 3.4 Demonstrations Time Schedule

The relationship between documents delivery and testing is outlined in the Figure 1. The testing activities were agreed and defined with each platform provider separately, which included agreement on the testing details, timetable as well as to deliver required Customer Furnished Items (CFI) to the site.

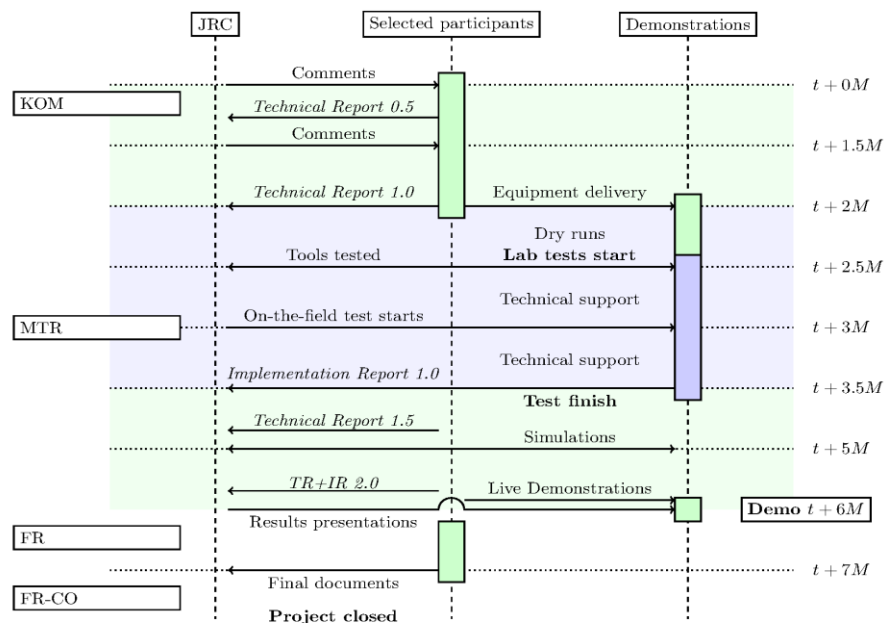

Figure 1 – Flowchart illustrating the documents delivery and projects timetable followed in the A-PNT tests at the JRC.

Given seven platform providers, their individual time table have been adjusted to provide optimal usage of testing equipment and facilities. Some of the platform providers could not present part (or for one all) of their technology at the JRC site. Therefore, part of the testing also took place outside of JRC, hosted by the platform providers at:

- Amsterdam, Netherlands;
- Granada, Spain;
- Paris and Grenoble, France;

- Madrid, Spain;
- Düsseldorf, Germany;
- San Jose, USA.

A timeline of all the testing sessions that were conducted with all the A-PNT demonstration platforms is shown in the Figure 2, where blue colour indicate tests conducted on site and red colour those conducted outside the JRC premises, in the locations listed above.

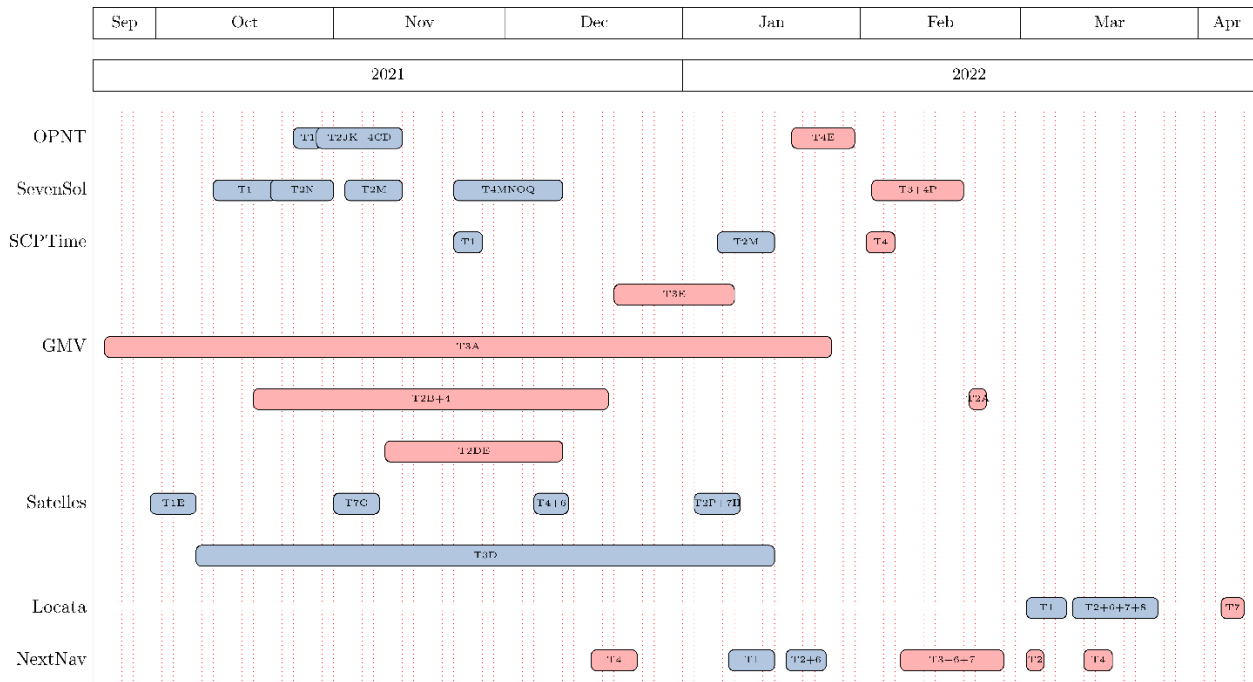

Figure 2 – Timeline of the A-PNT test campaign, both inside JRC (blue) and outside (red)



## 4 JRC's Reference Systems and Test Infrastructure

### 4.1 JRC Site Description

The JRC acts as the science and knowledge service for the European Commission. The *Ispra Site of the JRC*, located in Northern Italy, has been the main host of the A-PNT demonstrations. As depicted in Figure 3 it is covering over 170 ha with over 100 buildings (BGs), one to five-floor high, and 36 km of roads, consisting of forest, semi-urban, urban and rural areas with varied topography, including woodlands. This and the presence of the dedicated labs, including the *European Microwave Signature Laboratory* (EMSL), makes it ideal for the Alternative PNT testing campaign in varied conditions.

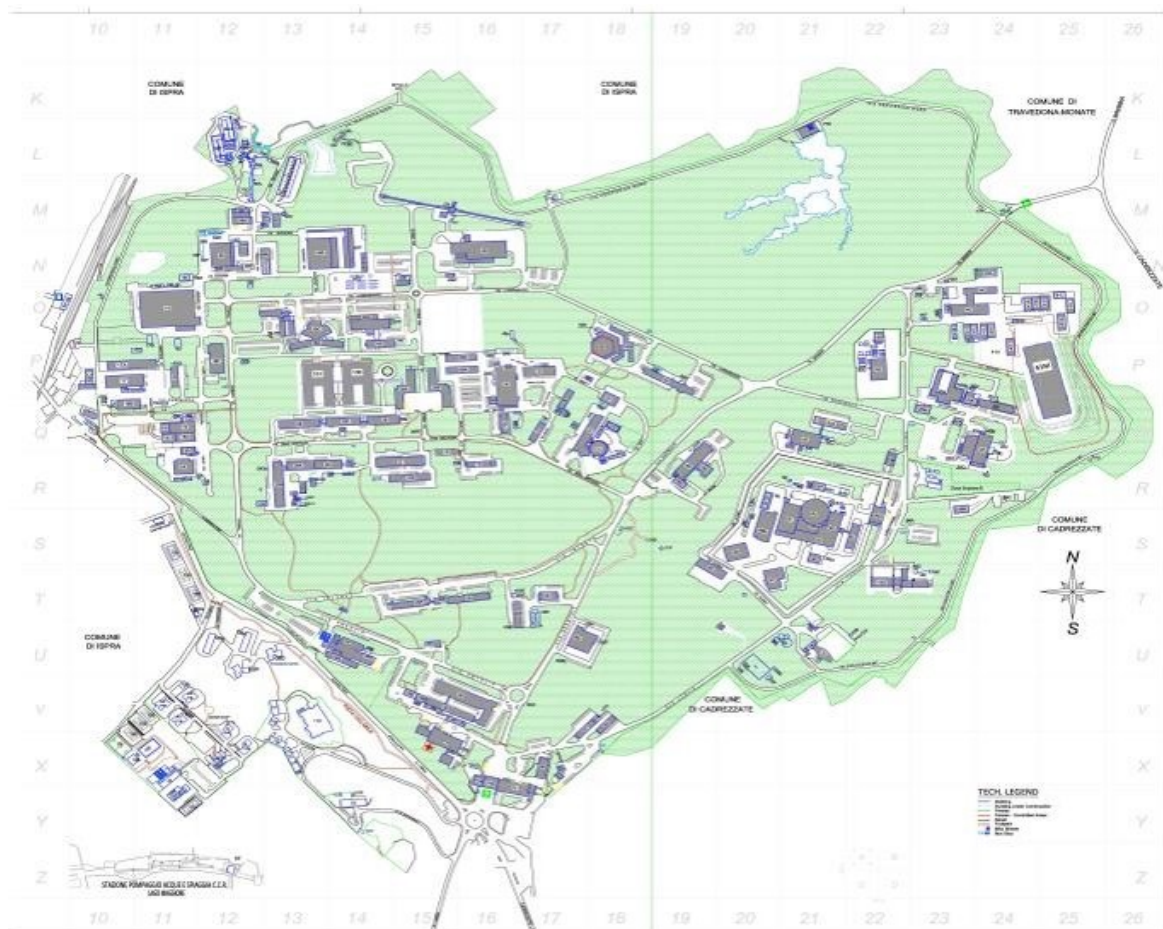

Figure 3. Ispra Site of the JRC

The JRC site hosted:

- The timing testing in the EMSL building (BG24), BG72C and BG48;
- The outdoor positioning testing across the site in three different environments - open, woodlands and urban;
- The indoor positioning testing in BG48 and BG102.

This required the following actions and facilities:

- A separate infrastructure and network access arrangements were organised for each platform demonstration and testing;
- Installation of transmitting equipment around the campus;
- Installation of dedicated equipment indoors;
- Timing Laboratory setup;
- Temporary License Granted by IT Spectrum Regulator (MISE) and licensed users (Railway and mobile operator) to transit within the 921.8845 – 927.0000 MHz, which allowed for up to 2h time transfers.

Overall, through the testing 6.1 GByte of test data was collected, including 3.2 Gbyte of PPS time difference log data collected, exceeding equivalent of 200 measurement days.

For the clarity, given the complexity of each setup, a Platform Under Test (PUT) refers to a whole setup of Devices under Test (DUT) and all interconnections, excluding JRC provided references. Here, DUT refers to a self-contained part of the PUT.

## **4.2 Timing Reference**

JRC has provided timing references for all the experiments conducted at the JRC Ispra site. The test rig was organised as follows:

- UTC (IT) references JRC time reference, consisting of Septentrio PolaRx5 and SRS FS725 Rubidium oscillator. GNSS signal was obtained from the antenna located on BG72C or BG24. This setup can provide both 10 MHz and 1PPS input to DUTs;
- Number of Agilent 3220A interval/frequency counters (TIC), monitoring PUTs 1PPS against time reference;
- Platform Under Test (PUT), layout of which is presented separately for each PUT in Chapter 5.

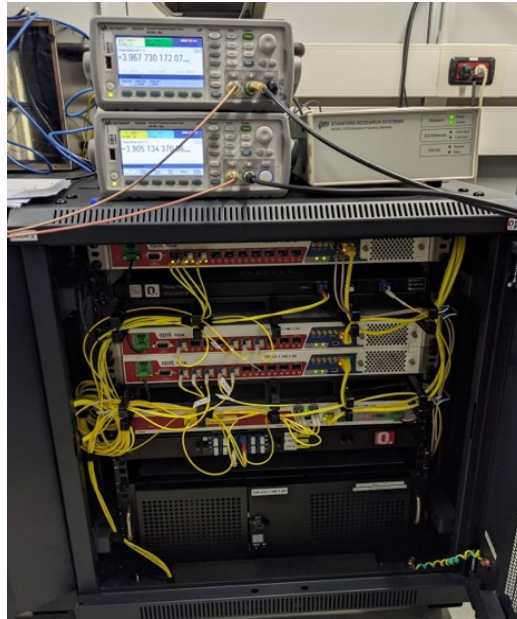

Figure 4. Example of JRC time rig setup for experiment

The test rig was set up separately for each platform provider, with cable delays calibrated. Before each tests a known offset (200-500 ns) was set at the Septentrio PolaRx5 receiver. This was intended to avoid DUT 1PPS arriving before reference. This setup was run for at least 12h, to verify the timing test rig performance and stability, usually against [Meinberg Lantime M300](#) or another Septentrio receiver.



Figure 5. Calibration setup, JRC time reference visible on top

Exact connection details, including number of TICs used, depends on the specific setup and are described in [\[AD.1-7\]](#) and summarised in section 5.

### 4.2.1 UTC(IT) Calibration of the JRC Time Rig

The above setup was calibrated by the *Istituto Nazionale di Ricerca Metrologica (INRiM)*, the Metrology Institute providing the official Italian UTC Time. Calibration allows using GNSS signals to virtually transfer JRC time reference to INRiM and gets its traceability to UTC with nanosecond accuracy. This allows to guarantee reference to *UTC(IT)* at the 1PPS output from JRC time reference.

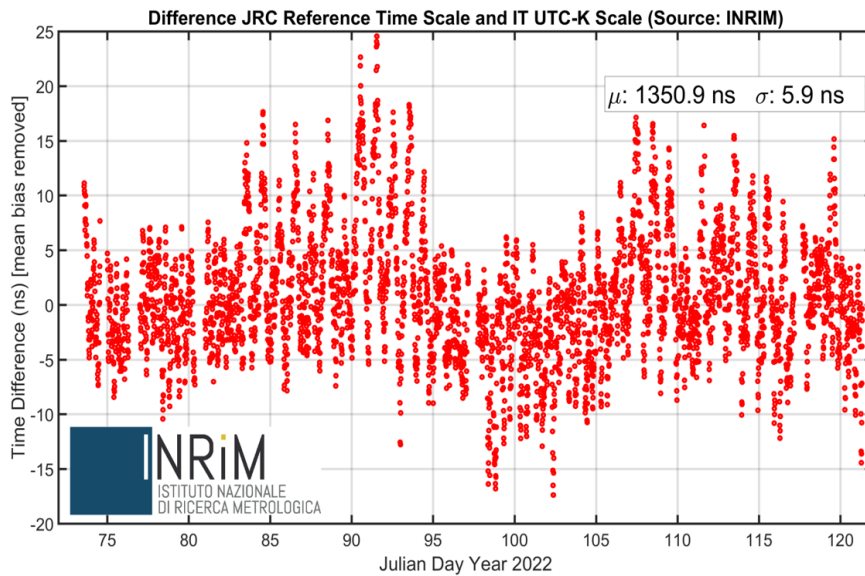

Figure 6. Results of INRiM 46 days calibration campaign

### 4.3 Surveying of the A-PNT Installation Sites

A grid of permanent points, in the European Terrestrial Reference Frame (ETRF), were established using GNSS RTK around the campus to support any outdoor trials. As part of the process, indoor reference was also established for BG102 and BG48.

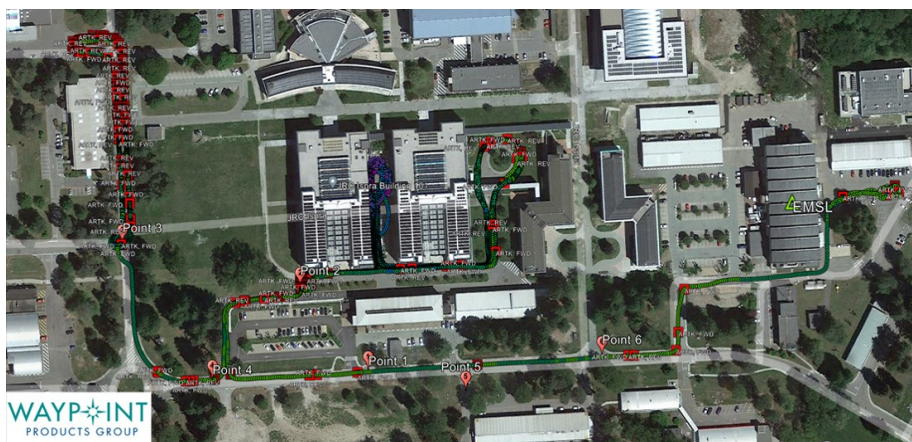

Figure 7. Example of kinematic test with visible permanent points

For the BG102, the single external reference point and Total Station were used to establish the absolute height of each building level (lower ground, ground, 1F, 2F, 3F) as a truth.





Figure 8. BG102 floor heights survey

The BG48 (ELSA, indicated as Workshop in [AD. 6]) required to establish internal coordinates, consistent with the ETRF. The following approach was taken:

1. Two reference points have been surveyed, in the ETRF, outside BG48 (Workshop);



Figure 9. Reference points outside and inside the BG48.

2. Traverse using the total station (hanging leg) established three points (marked as P1, P2, and P3 in Figure 9) were established inside the building, within the ETRF reference frame.
3. Platform provider, Locata, creates a local grid, parallel to the building wall. Using least squares Helmert 2D transformation three points inside were established in the local grid and tied the local grid to the ETRF reference frame.
4. Total station was used to create an indoor grid of 23 points in a 3m x 5m grid arrangement (Figure 10). A 1m x 1m grid of metal plates already embedded in the floor of the JRC Workshop was used as visual markers for the test, as shown below. This allows us to organise the test, visualise the indoor system and determine the test area.



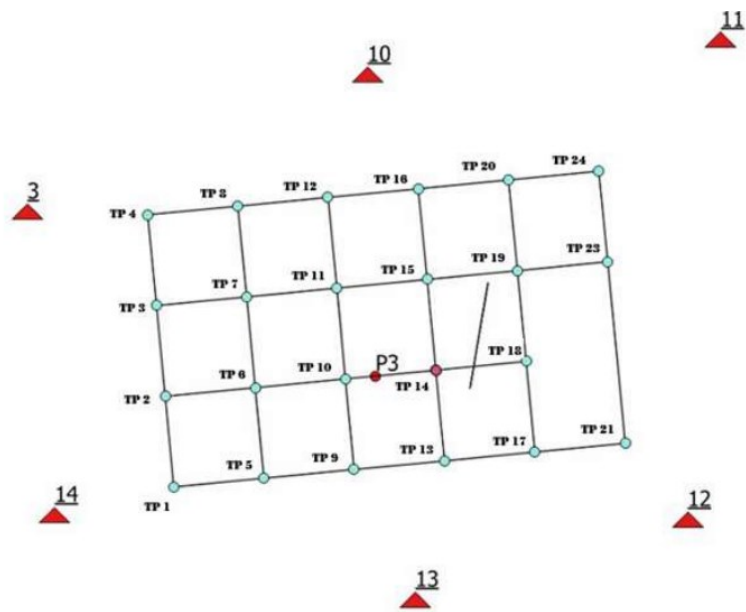

Figure 10. 23-points indoor grid inside BG48.

5. Six Localites radio beacons were placed inside the JRC Building 48 (Workshop), with their coordinates established using a local coordinate system. Rover's position was reported both in local coordinates and the ETRF global coordinates.

A dedicated moving platform, based on the trolley was set up for the kinematic experiment, with two variants - outdoor and indoor. In both cases, the platform consisted of truthing system, power supply, data logger (laptop) and DUT.

For the outdoor trials, the setup consisted of:

- Truthing system - Spirent AsteRx-U and Novatel SPAN CPT, connected to a high-raised GNSS antenna;
- power supply, a data logger (laptop) and space for PUT.

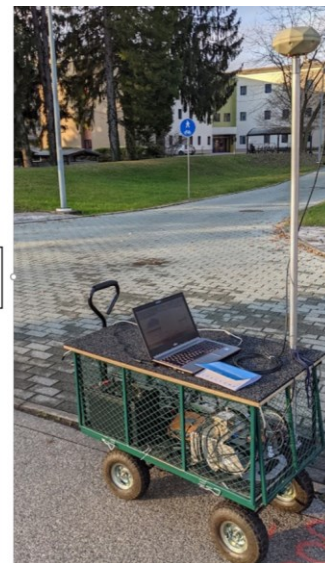
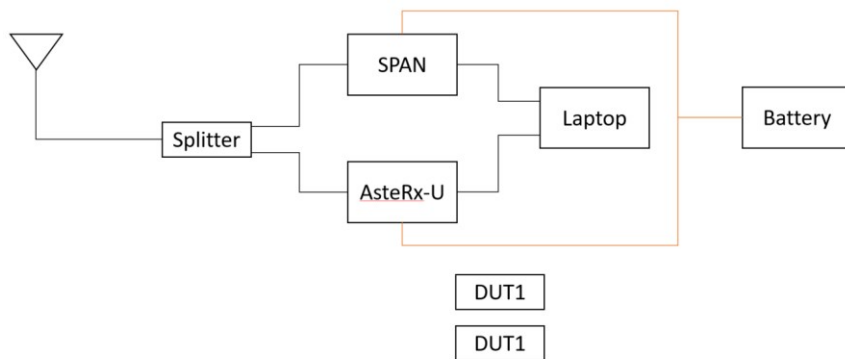

Figure 11. Schematic (left hand side) and picture (right hand side) of the external experimental set up.

For the indoor trials, the setup consisted of:

- Truthing system - survey 360 degrees prism mounted on top of Locata's Orb antenna;
- power supply, a data logger (laptop);
- DUT - Locata rover with the multipath-resistant Orb Antenna.

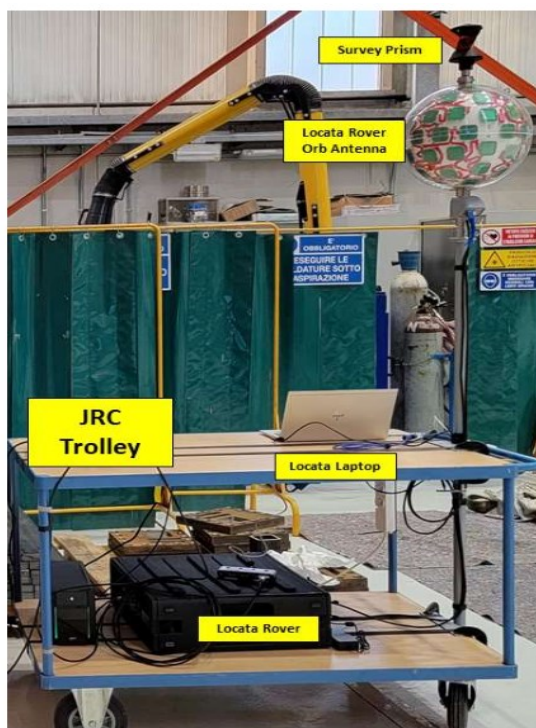

Figure 12. Indoor experiment set up

## 4.4 Analytical Methods

The test campaign aimed to understand the maturity, and nature and assess the performance of the proposed PNT platforms against the common baseline (KPIs) to understand the advantages and limitations of each technology. Analysis philosophy is a science-based, unbiased and interdependent agnostic testing of each service against the baseline. The purpose is to establish the strong and weak points of each proposed service, without directly competing for each service against each other. To streamline the size and readability of this document some results are not re-plotted here and should be checked in [\[AD.1-7\]](#).

### 4.4.1 Assessment of the Timing Accuracy

If we consider time generation, clocks phase noise has multiple coloured noise sources (including white), hence the standard deviation cannot provide a meaningful characterisation of their performance. To address these problems, the M-sample variance and (indirectly) the two-sample variance were developed. Those Allan Deviation based metrics were used in the [\[AD.1-7\]](#) to characterise the time generation stability, as per CFT.

For the sake of clarity, this report uses Maximum time interval error (MTIE) for time generation (including holdover) and peak-to-peak for time transfer as the most descriptive and easy to understand methods of describing its accuracy. MTIE, measure peak time deviation (maximum clock error) within the whole measurement interval, with the respect to the reference. It is best suited for the presented atomic clock's time generation and in this document is expected to be an equivalent of 3sigma (99.7 percentile). One exception was Satelles. Given the stability of its time generation, the accuracy in Table 17 was estimated using a normal distribution (3sigma, 99.7 percentile). As discussed in section 4.2, all participants were tested against UTC (IT).

The observed time transfer was mostly stable so peak-to-peak estimation was used. If this was valid, the standard deviation was reported as a simplified estimation of short-term noise. Mean on those occasions should be seen as a visualisation of system calibration and as such should be used very carefully, as better calibration is possible for the systems tested. One exception was the GMV computer network results. Given its unusual error distribution MTIE was used instead.

### 4.4.2 Assessment of the Positioning Accuracy

The 2D radio-navigation planar errors are correlated, hence the common practice is to assess those values against a Rayleigh distribution, and for GNSS using circular error probable (CEP), that is circle containing 50% of the un-biased error or Horizontal Navigation Standard Error (HNSE). Traditionally, this does not apply to height results and can be estimated from normal distribution. In this report, given the diverse system presented and for the sake of clarity, both planar and height values are reported against a normal distribution. This is further justified by analysis of static position box-plot, presented in section 5. Most show normal distribution with small skewness.

The static data was presented as boxplots for planar and height values. This allows to visualise separately the data points distribution, including spread and skewness for each static point observed. Figure 13 visualises the relationship between the boxplot and the normal distribution.

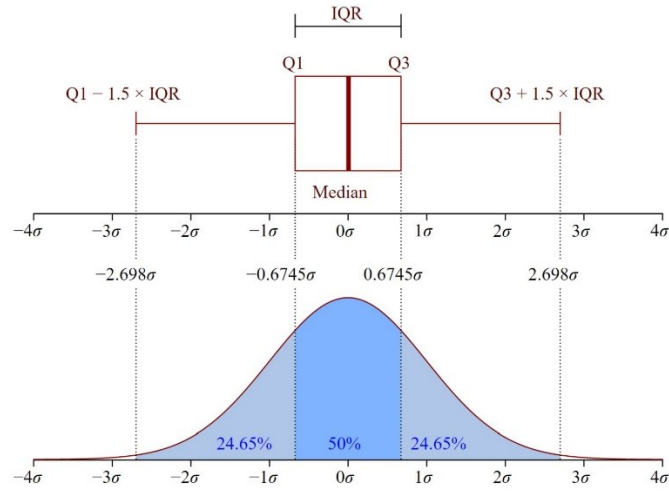

Figure 13 Relationship between boxplot and normal  $N(0, \sigma^2)$  distribution, adopted after Jhguch under CC BY-SA 2.5 licence.

For kinematic data, a Cumulative Distribution Function (CDF) was calculated for each path separately. CDF visualises the maximum HMSE value at a given quantile, as shown in Figure 14, for the normal distribution case.

To estimate the 95 percentile, we would look at the value at the intersection of the red line at the .95 y-axis and find an equivalent x value by drawing the red perpendicular red that intersects both the horizontal red line and the blue distribution plot. At the 95 percentile, HMSE can only take values from the x-axis marked red, with the vertical red line indicating the 95% threshold. Another way to understand it is that only 5% of observed observations exceed this threshold, so HMSE should be equal or smaller than it.

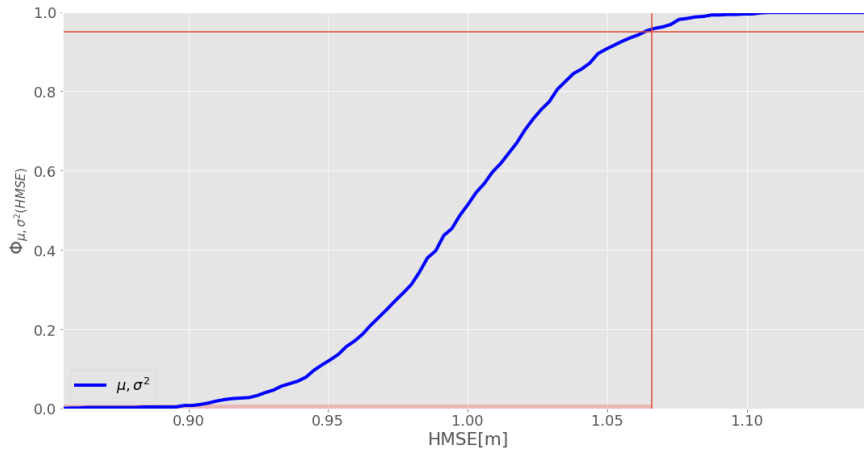

Figure 14 Example of CDF analysis, showing 95% percentile

To determine the availability of the service per location, time tags were treated as a proxy, as per equation ( 1 ). The dividend is the count of all the epochs observed with a valid time tag and divisor is count of all epochs under test.

$$availability = \frac{\sum t_i^{observed}}{\sum t_i} \quad (1)$$

## 5 Performance Evaluation Results

This chapter summarizes the main results of the tests performed by each technology provider. Depending on the specific technology platform, timing and/or positioning tests were carried out. The performed timing tests, can be described as:

- Time Generation, assessing time reference performance over 14 or 100 days, this also includes one day holdover capacity;
- Time Transfer over Fibre, understood as time transfer using optical wavelength modulation, as measured on the end node (end user);
- Time Transfer over Networks, understood as time transfer using electrical current modulation;
- Time Transfer Over-the-Air (OTA) , understood as wire-less time transfer;
- Resilience to external treats, remote monitoring and related capacity of the platform.

Similarly, the positioning tests can be described as:

- Static Outdoor;
- Static Indoor;
- Kinematic Outdoor;
- Kinematic Indoor;
- Resilience – for three PNT platforms, resilience for both time and position are given.

Table 1 and Table 2 report, respectively, the mapping between each technology provider and the tests executed, for the timing and positioning tests respectively. A cell with a tick (✓) corresponds to a test carried out, which are described in the following subsections. A cell with an asterisk (\*) corresponds to a test that could not be completed because of the unavailability of some test equipment (e.g., a timing source with the required stability could not be made available) or was not required in the context of the proposed test plans. Regarding the time generation, participants who did not demonstrated it at the JRC where able to either practically discuss the use of NMIs or indicate it availability at other deployment.

	Time Generation	Holdover	Time Transfer Fibre	Time Transfer Networks	Time Transfer OTA Outdoor	Time Transfer OTA Indoor	Resilience
<b>OPNT</b>	(*)	(*)	✓		✓		✓
<b>7 Solutions</b>	✓	✓	✓				✓
<b>SCPTIME</b>	✓	✓		✓			✓
<b>GMV</b>	✓	✓	✓	✓			✓
<b>Satelles Inc</b>	✓	✓			✓	✓	✓
<b>Locata</b>	(*)	✓	✓	✓	✓	✓	✓
<b>NextNav</b>	✓	✓			(*)	✓	✓

Table 1. Timing tests executed by each technology provider.

	Static outdoor	Static indoor	Kinematic Outdoor	Kinematic Indoor
<b>Satelles Inc</b>	✓	✓	✓	
<b>Locata</b>	✓	✓	✓	✓
<b>NextNav LLC</b>	✓	✓	✓	✓

*Table 2. Positioning tests executed by each technology provider.*

The following sub sections present the main results of the tests, for each provider including:

- a brief overview of the specific technology’s functional characteristics, along with descriptions of the test set-ups;
- the assessment of technology performance evaluated against the KPI, described in section 3.2;
- the results of the tests, as per Table 1 and Table 2.

Exhaustive details on the tests execution and results can be found in [\[AD. 1\]](#).

## 5.1 OPNT

IEEE-1588-2019 High Accuracy (HA) profile, widely known as White Rabbit protocol is a time & frequency distribution protocol, developed at the European Organization for Nuclear Research (CERN), which combines Precise Time Protocol (PTP) packets with the frequency base of Synchronous Ethernet (SyncE) to provide sub-nanosecond time transfer accuracy over an optical fibre. A new PTP version 2.1 includes White Rabbit generalized as its High Accuracy Profile. As this solution is based on optical links, which are part of standard telecom network, and not susceptible to any form of RF interference.

Besides offering hardware and knowledge to build a wired infrastructure based on White Rabbit OPNT has developed additional features that allow White Rabbit to be used as part of critical infrastructure. In addition to that OPNT has developed technology to monitor and timestamp radio signals (mobile phone, GNSS, etc.), in order to detect and (if necessary) correct timing errors (drift).

The tests conducted on the OPNT A-PNT platform at the JRC demonstrated both the time and frequency transfer over fibre utilizing the White Rabbit protocol and also over a radio link with signalling in accordance with the Long-term Evolution (LTE) standard. Subsequently to the tests made at the JRC, OPNT also reported performance results obtained in an operational installation in the Netherlands, with White Rabbit fibre links of several tens of km and having the Dutch NMI VSL, providing Netherlands legal time, as the source.

Prior to these tests and due to the difficult logistics to ship a Caesium Standard clock to be used as a time source, it was agreed to use a time source provided by the JRC. This time source was generated with a PPS and 10 MHz reference from a high-end Rubidium standard disciplined with multi-frequency multi-constellation GNSS receiver. This time source was calibrated with traceability to an UTC(k) realization of the Italian Metrology Institute INRIM.

OPNT has demonstrated:

- Transfer time & frequency over long distances with better than 1 nanosecond accuracy using the White Rabbit protocol;
- Technology to monitor and timestamp radio signals (mobile phone, GNSS, etc.) in order to detect and (if necessary) correct timing errors (drift). Monitor and Correct devices with a drifting time source by monitoring their transmitted radio signal with better than +/-200 nanosecond accuracy;
- Detect a time source going out of specification and switchover to a valid time source
- Outside of the scope of the test campaign, technology was demonstrated to enable terrestrial positioning [\[RD. 10\]](#).
- Technology is backward compatible with PTPv2.

### 5.1.1 Key Performance Indicators (KPI's)

The timing key performance indicators are listed in Table 3 and Table 4, for the tests performed over optical fibre link and those over OTA link respectively.

Timing Performance KPI	Number of Days after GNSS Outage		
	1 day	14 days	100 days
<b>Availability (%)</b>	100%	100%	99.9999%
<b>Continuity (per hour)</b>	100%	100%	99.9999%
<b>Integrity (per hour)</b>	100%	100%	99.9999%
<b>Time To Alarm (second)</b>	1	1	1
<b>Timing Accuracy to UTC (3sigma)</b>	0.1 ns	0.1 ns	0.1 ns
<b>Within a metro</b>	0.5 ns	0.5 ns	0.5 ns
<b>&lt; 250 km</b>	1 ns	1 ns	1 ns
<b>250 – 1000 km</b>	2.5 ns	2.5 ns	2.5 ns
<b>EU Wide</b>	5 ns	5 ns	5 ns
<b>Time synchronization (Allan Deviation / 3 sigma)</b>	TBD	TBD	TBD
<b>Timing Stability (Allan Deviation)</b>	TBD	TBD	TBD
<b>First time to provide services upon cold start-up</b>	20 m	20 m	20 m

Table 3. Performance indicators over optical fibre link of the OPNT platform.

Timing Performance KPI	Number of Days after GNSS Outage		
	1 day	14 days	100 days
<b>Availability (%)</b>	100%	100%	99.9999%
<b>Continuity (per hour)</b>	100%	100%	99.9999%
<b>Integrity (per hour)</b>	100%	100%	99.9999%
<b>Time To Alarm (second)</b>	100%	100%	99.9999%
<b>Timing Accuracy to UTC (3sigma)</b>	10	10	10
<b>Within a metro</b>	200 ns	200 ns	200 ns
<b>&lt; 250 km</b>	NA	NA	NA
<b>250 – 1000 km</b>	NA	NA	NA
<b>EU Wide</b>	NA	NA	NA
<b>Time synchronization (Allan Deviation / 3 sigma)</b>	TBD	TBD	TBD



Timing Performance KPI	Number of Days after GNSS Outage		
	1 day	14 days	100 days
<b>Timing Stability (Allan Deviation)</b>	TBD	TBD	TBD
<b>First time to provide services upon cold start-up</b>	20 min	20 min	20 min

Table 4. Performance indicators over OTA link of the OPNT platform.

### 5.1.2 A-PNT Technology Under Test

The setup adopted in the tests is sketched in Figure 15 and consists of TS10 timing switches acting as nodes:

- Nodes A and B, act as grandmasters, locked to UTC(k) external time reference. They are both connected to JRC time source 1PPS and 10MHz output provided via splitter.
- Node E is equivalent of the end user connection and where setup accuracy is assessed against JRC UTC time source.
- Node C is used as wander generator, used in the Resilience test.
- Node F is not part of the test setup. It is used internally by platform provider to measure the time. offsets and collect data, acting as multi-port TIC.

The whole set-up presented fulfil the purpose of two demonstrations:

- The left hand side setup, marked in blue in Figure 15, is used for WR (White Rabbit) testing, and it consists of Nodes A, B and E.
- The right hand side setup, marked in red in Figure 15, is for Radio Signal Time stamping Unit (RSTU) demo, and consists of Nodes C and D.

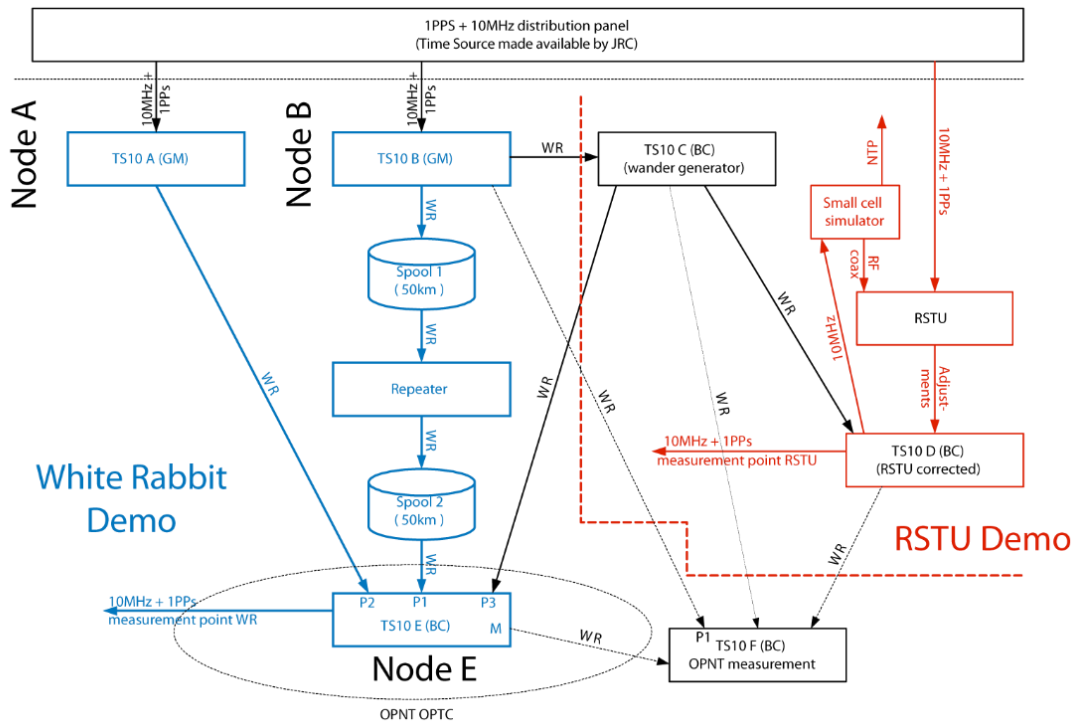

Figure 15. Logical set up for the performance evaluation tests on the OPNT platform.

### 5.1.3 Time Transfer Fibre

Two time transfer demonstrations were carried out.

The first was conducted at the JRC Ispra, in a controlled laboratory conditions, with the scope to measure the time and phase offset between Node B (blue line) and Node E (red line), separated by a two spools of 50 km fibre each, with a repeater in between, as shown in Figure 15.

Figure 16 show time transfer results, as recorded at Node E and measured over approx. 72 hours. The measured time stability is 57ps peak-to-peak with 8.3ps of standard deviation. The Node A offset is shown in purple, while the blue curve refers to the stability of Node B.

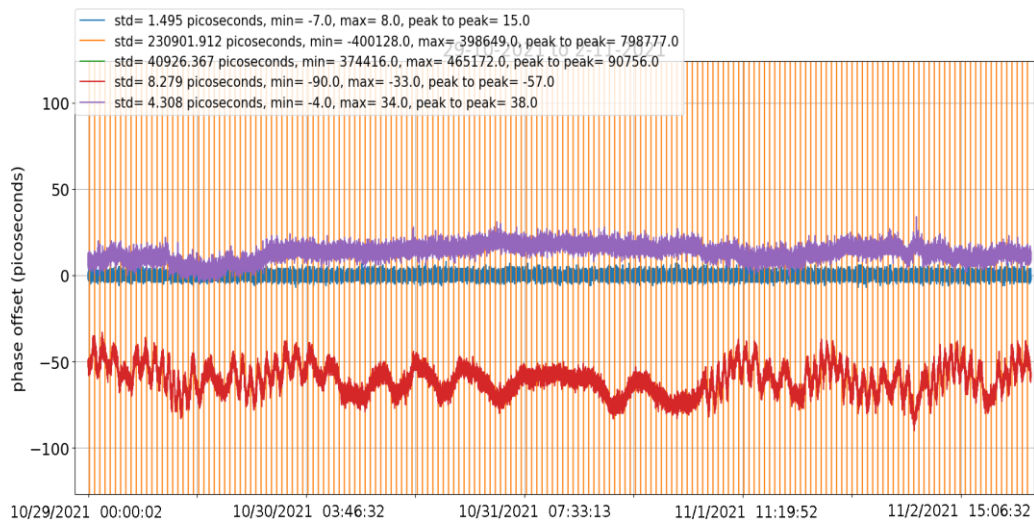

Figure 16. Results of the link frequency stability test of the OPNT platform.

The second is an example dataset from the real world deployment. This commercial WR link is deployed by OPNT between *VSL*, the Dutch Metrology Institute, and Nikhef, the *Dutch Institute for Nuclear physics research*. Time was transferred in a loop, as illustrated in Figure 17, from VSL (GM) through a datacenter (BC1) to Nikhef Amsterdam (BC2) which then returns to the VSL (Slave TS10) via datacenter (BC3).

The phase offset, presented in the Figure 18, was measured between the VSK Grandmaster and the end node (Slave TS10), demonstrating a time stability over three days of 200 ps peak-to-peak, with 22 ps of standard deviation.

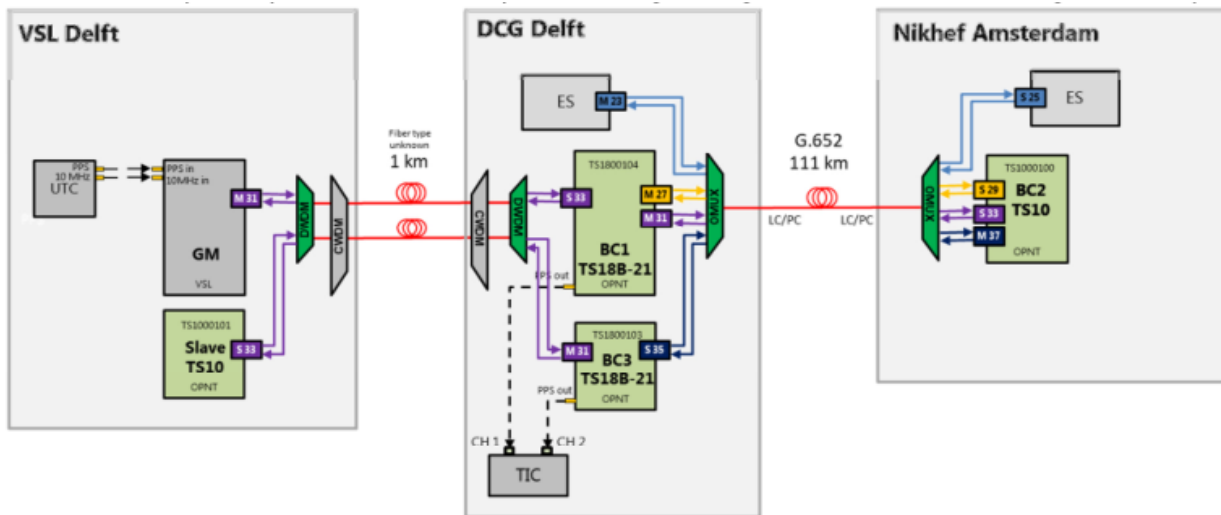

Figure 17. Sketch illustrating a current deployment of the time transfer technology of OPNT in the Netherlands.

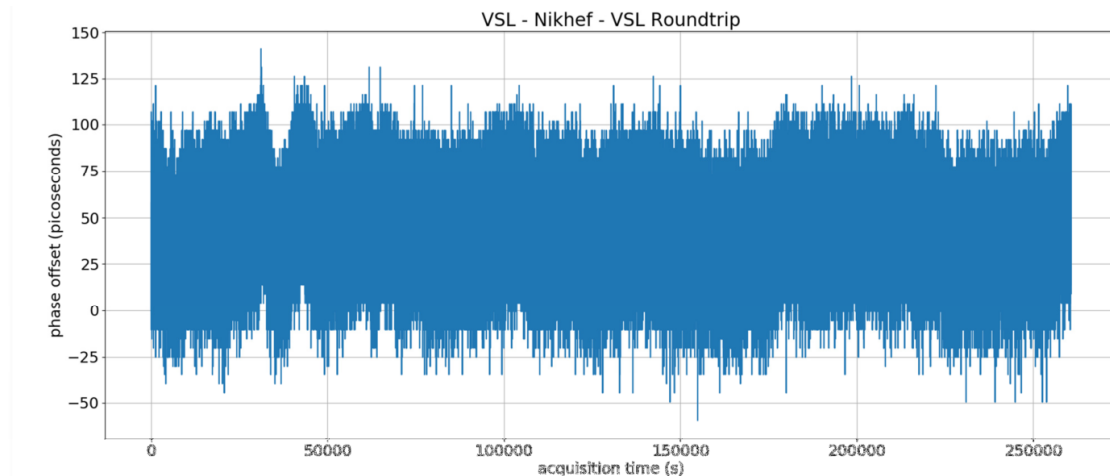

Figure 18. Measurements of the round trip delay between two nodes in a country-wide network deployed by OPNT the Netherlands.

### 5.1.4 Time Transfer OTA Outdoor

The OTA time transfer demonstrated RSTU (Radio Signal Time stamping Unit), which purpose is to synchronise remote clocks by providing reference time signals over the air, using LTE signals. The demonstration took place over two tests: in the former, at the JRC lab, due to safety restrictions, the signal was transmitted via the copper link, while the latter has been conducted in the Netherlands, using an LTE signal.

#### 5.1.4.1 JRC lab demonstration

The setup is depicted on the right hand side of Figure 15, in red colour. RSTU is connected to the UTC source and corrects Node D (TS10 D). Node D provides a drifting 10MHz + 1PPS to the small cell simulator which is connected by coax cable to RSTU (as due to safety restrictions OTA signal was not permitted).

Node C introduces an artificial phase wander simulating a clock drift ( $\pm 500$ ns using a triangle shape) provided via the WR link. The objective is for RSTU to compensate for this drift. TS10 D is fed from drifting Node C via a White Rabbit link. The RSTU is synchronized to the primary clock and thus will measure the phase offset between the received signal and the primary clock. The measured offset is fed into TS10 D to counteract the drift generated by TS10 C.

*The results of the test, conducted over 72 hours, are presented in*

Figure 19: with orange line clock drift up to  $\pm 400$ ns (800ns peak to peak) generated by Node C, which is corrected by RSTU within  $\pm 100$ ns with respect to the clock source, as shown by the green line (Node D) equivalent of end user mobile tower.

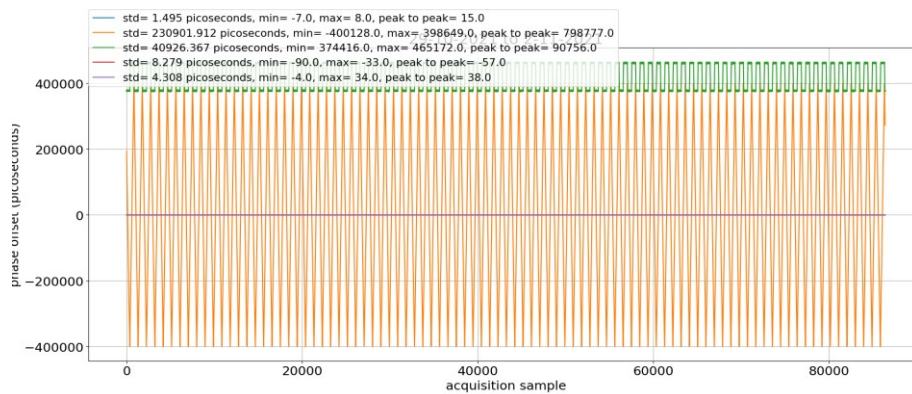

Figure 19. Radio link frequency stability test results on the OPNT platform.

#### 5.1.4.2 Netherlands demonstration

The test in Amsterdam, Netherlands, used an LTE signal received from mobile base stations. For this, the baseline setup of Figure 15 has been modified as per Figure 20. In this case, the direct connection between the RSTU and the small cell simulator is replaced by a power splitter and a LTE antenna so that the RSTU can receive both the small cell simulator and outside (real) LTE towers signals.

The results of the tests conducted over 39 hours are summarized in [AD. 1]. They refer to the monitoring of three frequencies (1 815MHz, 950MHz and 816Mz) and the small cell simulator, operating at 2 120 MHz. For the existing LTE towers, the time was maintained within 100 ns, and within 150 ns for the small cell simulator.

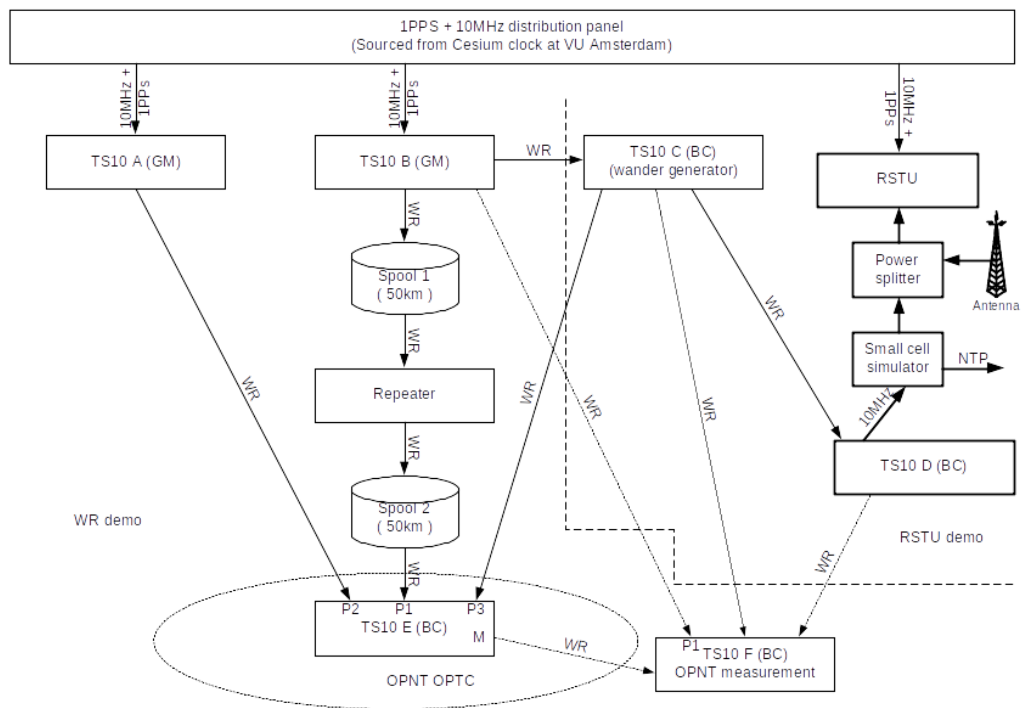

Figure 20. Logic setup of the test performed by OPNT using existing base stations.

### 5.1.5 Resilience

The OPNT Navigator acts as Network Management System (NMS), monitors hardware and the performance of the link, generates reports and receives/sends alarms. Each piece of hardware can be also accessed remotely. These enhanced monitoring, diagnosis and cybersecurity features are common across all tested platforms and are a sample of the emerging PNT systems.

Additionally, during the resilience demonstrations presented in [AD. 1], OPNT was also able to show the ability to:

- Switchover between time sources. In the demonstration switch from one clock source to the other was transparent, without a jump in time, to downstream devices;
- Detect a time source going out of specification and switch over to a valid time source. In the demonstration, artificial clock drift was introduced on the primary time source. Once the time drifted beyond the threshold level, the system switched to an alternative time. The time accuracy to the end user stayed within 2.1 ns, using pre-define threshold. System is providing internal measurements at the 1 ps level.

## 5.2 Seven Solutions SL (Safran Group)

IEEE-1588-2019 High Accuracy (HA) profile, widely known as White Rabbit protocol is a time and frequency distribution protocol, developed at the European Organization for Nuclear Research (CERN), which combines PTP packets with the frequency base of Synchronous Ethernet (SyncE) to provide sub-nanosecond time transfer accuracy over an optical fibre. A new PTP version (IEEE 1588-2019) includes White Rabbit generalized as its High Accuracy Profile.

The technology uses multiple sources of time (GNSS, atomic clock, NMI, etc.) in order to provide network resiliency, and requires a fiber network between the end user and the clocks to distribute the timing via WR protocol. Those sources are acting as backup to each other to ensure time & frequency transfer with sub-nanosecond accuracy and picosecond precision in case of failure of one of the time sources. As this solution is based on optical links, it is not susceptible to RFI.

Seven Solutions SL demonstrated the time and frequency distribution system utilising White Rabbit, combining both hardware and software. The company operates a Time as a Service (TaaS) business model. It is worth mentioning that, during the testing campaign, in March 2022, Seven Solution became a part of the Orolia Group, which in turn is owned by the Safran Group.

Seven Solutions SL has demonstrated:

- Time generation using PHM;
- WR time transfer and monitoring using the SNMPv2/v3 protocols for management and communication and web GUI, which also support hardware monitoring;
- deployment and monitoring of the WR using interoperability hardware;
- virtual clock, abstracting the use of timing sources to discipline the local oscillator;
- resilience of the WR network and the time provision.

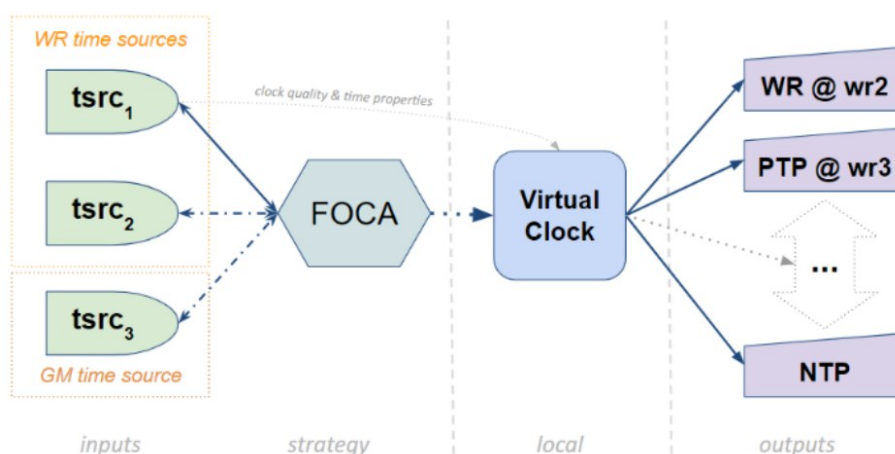

Figure 21. Virtual Clock diagram implemented in the Seven Solutions platform.

Seven Solutions, similarly to other WR technologies, provided multiple time sources. They introduced the concept of "Virtual Clock" (see Figure 21) to abstract the way the timing sources discipline the local oscillator and visualise time accuracy.

### 5.2.1 Key Performance Indicators (KPI's)

The timing key performance indicators are listed in Table 5, for all the tests.

Timing Performance KPI	Number of Days after GNSS Outage		
	1 day	14 days	100 days
Availability (%)	99.7%	99.7%	99.7%
Continuity (per hour)	99.9%	99.9%	99.9%
Integrity (per hour)	99%	99%	99%
Time To Alarm (second)	1	1	1
Timing Accuracy to UTC (3sigma)	<1ns	<1ns	<1ns (expected)
Timing Stability (Allan Deviation)	8.5e-17		
First time to provide services	1 min	1 min	1 min

Table 5. Summary of the observed performances on the Seven Solutions platform.

### 5.2.2 A-PNT Technology under Test

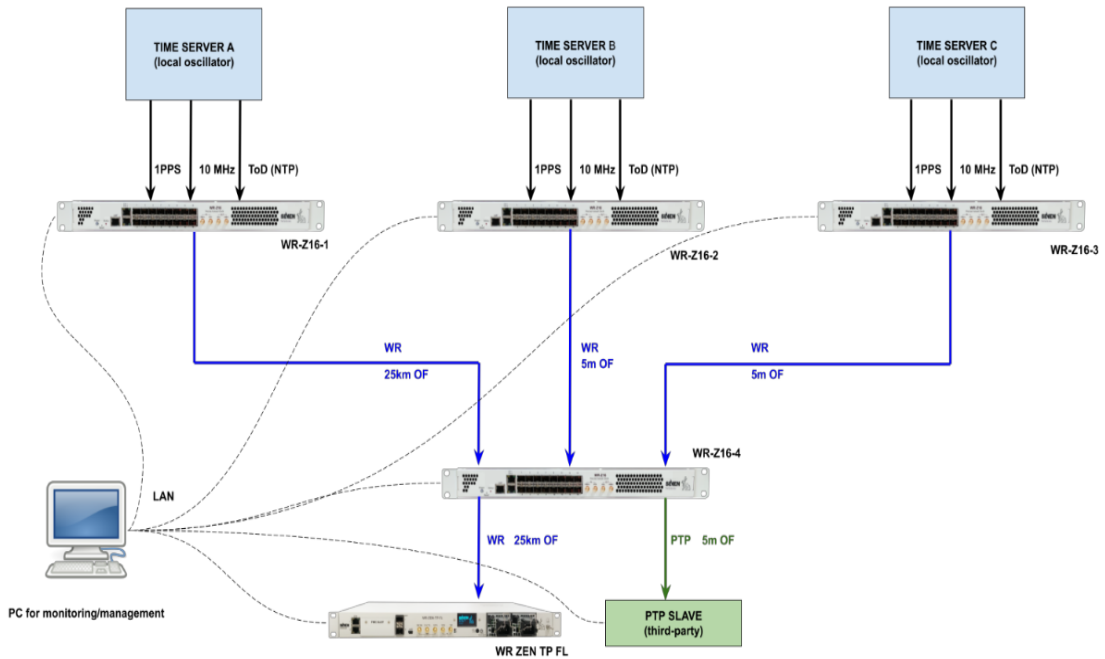

Figure 22. Test-up used in the performance assessment of the Seven Solutions platform.

The general test topology is presented in Figure 22. The SecureSync Time server, fed by a GNSS receiver (not shown in the figure) provides time to three WR-Z16 used as Time Servers, marked



as A, B, and C in the scheme. In details, A always acts as Grandmaster (GM), while B and C are used in Resilience demonstrations and act as either GM or time fan-out. WR-Z16-4, connected to time servers by 25 km fibre acts as backbone and WR ZEN TP FL, connected to WR-Z16-4 by another 25 km fibre is equivalent to the end user. The measurements of the time transfer delays have been conducted against a UTC source provided by JRC. More details can be found in [AD. 2].

### 5.2.3 Time Generation

A time generation test was conducted in Spain, utilising a Passive Hydrogen Maser (PHM) provided by the University of Malaga. The setup, shown in Figure 23, is very similar to the one deployed in Ispra.

The Local Passive Hydrogen Maser VCH-1008 has been synchronised with the UTC time scale of the *Spanish Real Observatorio de la Armada (ROA)* using the common view time transfer technique. The PHM used was stabilised using this procedure, and disconnection from the GNSS feed started the test. The clock was in the free-run condition for 80 days and its MTIE, against the UTC (IT) was 280 ns.

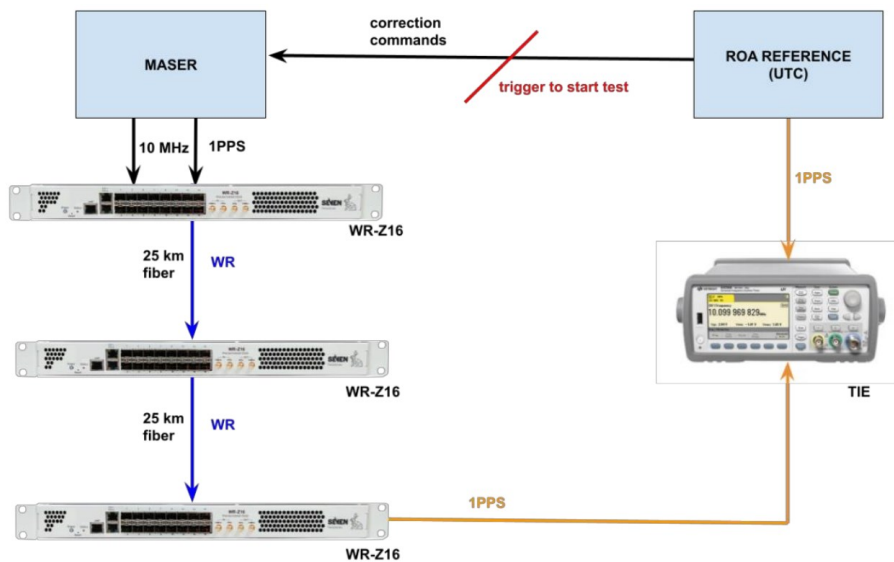

Figure 23. Time generation test setup topology used by Seven Solutions.

During the JRC laboratory test, Seven Solution demonstrated the holdover performance of the Rubidium clock, deployed in the WR-Z16, intended to bridge shorter timing provision gaps. The test was conducted using the setup of Figure 23. Firstly Time Server A clock connects to SecureSync and is conditioned for over 24h. Then the test starts by removing 1PPS and 10MHz connection to SecureSync. Time drift is measured over 24h.

Seven Solution guarantees that, within 24h of the learning period, this drift will not exceed 1.5us offset after 24h of operation, in agreement with the industry (telecom, finance, datacenter, etc.) requirements. Seven Solutions run large number of tests verifying this performance, as shown in Figure 24, where N indicates number of the test conducted. The set of 5 tests were run at JRC, demonstrated similar performance. The results of the JRC trial, summarized in [AD. 2], demonstrated worse performance, although the reason of such behaviour has not been identified.

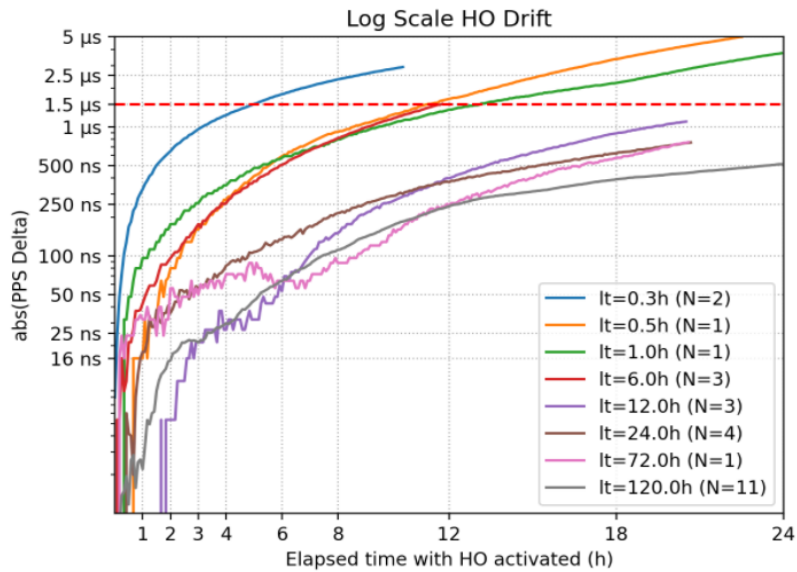

Figure 24. Holdover performance, as reported by Seven Solutions.

#### 5.2.4 Time Transfer Fibre

Test was conducted at the JRC Ispra Lab, using setup presented in Figure 22. The results, measured during approx. 29 hours, demonstrated time stability of 89 ps peak-to-peak with 16 ps standard deviation.

#### 5.2.5 Resilience

Similarly to other platform providers, Seven Solutions offers a turn-key system that monitors hardware and the performance of the links, generates reports and receives/sends alarms. Each piece of hardware can be also accessed remotely.

Additionally, during the resilience demonstrations, Seven Solution has demonstrated:

- Switchover between time sources (failover) in case of time source failure (optical link failure).
- Detect a drift on the time source and switchover to another time source. Lab tests used artificial clock drift on the primary time source. Once the time drifted beyond the threshold level, the system switched to an alternative time. Time accuracy provided by the system stayed within 25 ns.
- Interoperability of their hardware with that of other manufacturers.

### 5.3 SCPTIME

Time distribution via computer networks rely on the computer time protocols such as NTP or PTP. SCPTIME® (Secured Certified Precise and Traceable Time) disseminate UTC Time using computer networks using proprietary time protocol, NTP STS, intended to increase the integrity of the time information transmitted. SCPTIME proposes a centralised timing infrastructure that is connected upstream to a legal or official time source (UTC). This structure allows to monitor and maintain the full traceability of the legal time in the end-to-end transmission from the source to the end user device.

Platform provider has demonstrated:

- Computer network based secured & traceable time dissemination from French UTC(OP), provided by the *Observatoire de Paris*.
- Network maintain log of all events and monitor itself to detect the outage.

#### 5.3.1 A-PNT Technology under Test

JRC testing focused on the BiaTime D Premium service package, offering microsecond level accuracy. Tests conducted at the JRC utilised bundled package with ‘BiaTime Box’ hardware and a software agent. The infrastructure is presented in Figure 25. SCPTIME infrastructure overview. Equipment located at the JRC was connected to the SCPTIME infrastructure in France using NTP (STS) protocol aligned with the time scale UTC(OP). This includes the time production based in Paris, distributed through the Grenoble servers. JRC setup presented in the bottom left corner consisted of the SCPTview Client and ATS time server with holdover capacity (Rb), acting as end user terminal. Its 1PPS signal was compared with the UTC source, provided by JRC. More details can be found in [AD. 3].

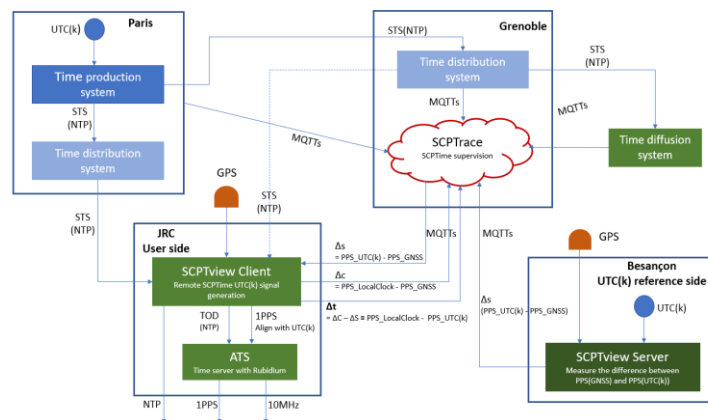

Figure 25. SCPTIME infrastructure overview.

#### 5.3.2 Time Transfer Networks

Tests conducted at the JRC Ispra utilised ‘BiaTime Box’ hardware and software package, using SCPTIME infrastructure in France as discussed in previous section. This service was established

temporary in combination with GPS signal and its performance was verified over few days, with timing performance below 35 ns peak-to-peak.

To demonstrate GNSS independent solution, BiaTime D Premium Service Package deployed holdover Rubidium clock. This holdover is designed to bridge timing provision gaps at the user end for up to 24h. Results, presented in the Figure 26, demonstrated sub-microsecond level accuracy within 24h.

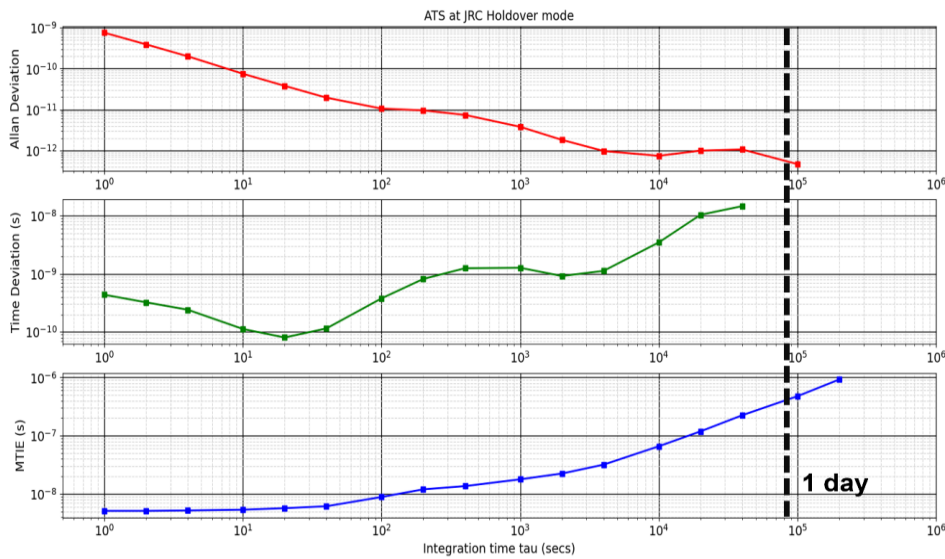

Figure 26. SCPTIME holdover performance operating in the absence of GNSS.

### 5.3.3 Resilience

The resilience test has been conducted in data centres in Paris and Grenoble, demonstrating back-end resilience and continuity of timing services. Those demonstrated end user equipment resilience to the failures of:

- the connection loss to SCPTIME supervision system of Diffusion time device;
- changeover between different SCPTIME distribution points due to hardware failure;
- CPTIME network failure.

Each scenario demonstrated monitoring and logging of the events using SCPTIME Management system interface.

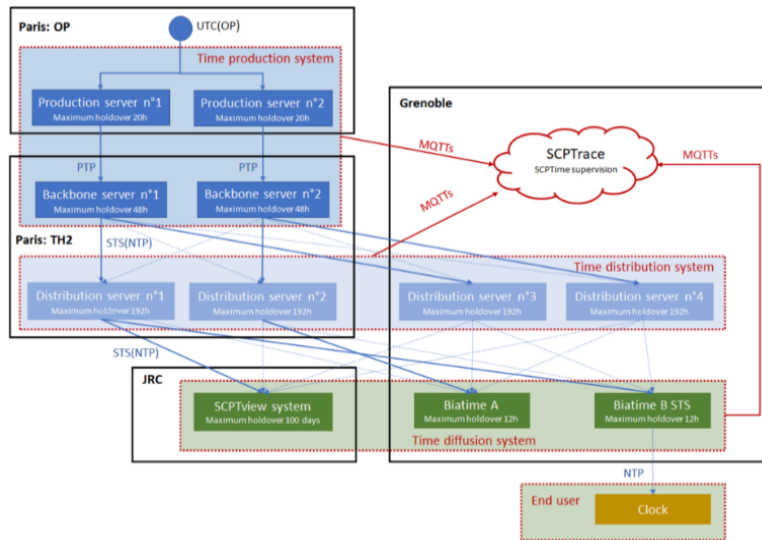

Figure 27 Infrastructure architecture for the resilience test used by SCPTIME.

## 5.4 GMV Aerospace and Defence SAU

GMV Aerospace and Defence SAU demonstrated WANTIME4EC project, consisting of:

- Time generating Passive Hydrogen Maser with Frequency stepper, synchronized with the German UTC time scale UTC(PTB) via GNSS Common-View.
- Two links based on standard network services with clients using DTM (Nimbra box) and GNSS (WANTime receiver).

Time distribution via computer networks can be conducted using Dynamic synchronous Transfer Mode (DTM). This protocol implements a time division multiplexing and a circuit-switching optical network technology. The DTM architecture was standardized by the [European Telecommunications Standards Institute \(ETSI\)](#) in 2001. The accuracy depends on the jitter and network asymmetry. The first factor is directly related to the intensity of the other, non-related traffic. This can be mitigated by increasing the packet rate to probe the delay more often, which require guaranteed amount of bandwidth. Practical experience indicates that requesting the right quality from the MPLS network is the critical and sufficient requirement for the below microsecond accuracy, though this can be expensive. The platform provider has demonstrated:

- Time generation using passive hydrogen maser (PHM).
- Time transfer using fibre based WR and computer network based DTM and NTP protocol. Last item did not fulfil the test campaign KPIs.
- Monitoring of the computer network time transfer.

All tests were conducted in Madrid, Spain.

### 5.4.1 Key Performance Indicators (KPI's)

The timing key performance indicators are listed in Table 6.

Performance parameter (X days after GNSS outage)	1 day	14 days	100 days
Availability (%)	> 99.0	> 99.0	> 99.0
Continuity (%/per hour)	> 99.0	> 99.0	> 99.0
Integrity (failures per hour)	< 10 <sup>-4</sup>	< 10 <sup>-4</sup>	< 10 <sup>-4</sup>
Time to Alarm (seconds)	N/A	N/A	N/A
Frequency stability (Allan Deviation)	N/A <sup>2</sup>	N/A	N/A
Timing accuracy to UTC (ns, 3-sigma)	< 1000	< 1000	< 1000
Initialization time <sup>3</sup> (days)	0	0	0
Metrological traceability to UTC	Partially	Partially	Partially

Table 6 WANtime performance levels (client side) reported by GMV.

### 5.4.2 A-PNT Technology under Test Setup

Time transfer tests were conducted between two GMV premises: Tres Cantos, near Madrid, and Valladolid, 130 km away from each other, as represented in Figure 28. The Tres Cantos office operates two PHM chains, marked as A and B. Both chains utilise Passive Hydrogen Maser (PHM) VCH-1008. The UTC(PTB), provided by the *German NMI PTB*, is obtained using the common view time transfer technique. This GNSS delivered time feeds to the stepper, which steers the PHM towards UTC(k), as shown on the left side of Figure 28.

---

<sup>2</sup> Technically it would be possible to calculate the Allan Deviation at the client location, but it was not done as this measure would be dominated by the network jitter; also, it would be difficult to define a priori performance levels for the client ADEV. In any case, observations were recorded at the client side in the tests T2x and next to time server (PHM) as part of the tests T3x.

<sup>3</sup> It assumes that the server has been properly initialized.



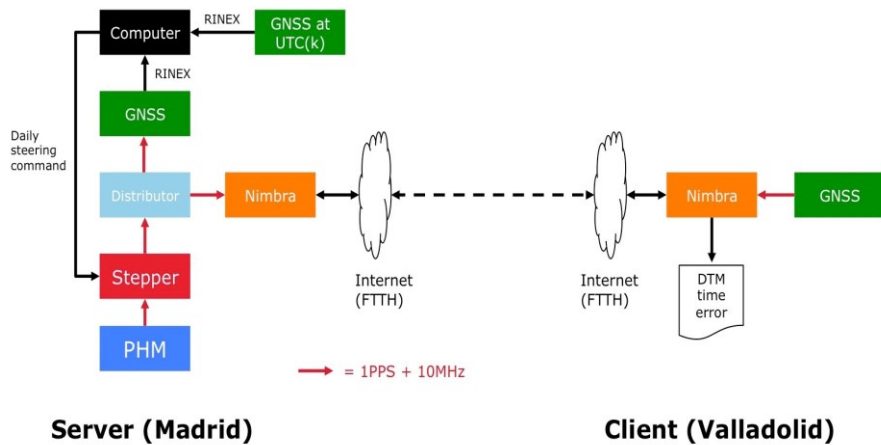

Figure 28. Schematics of the tests carried out at the GMV premises.

For the duration of the trials, Chain A was disconnected from GNSS (the corrections were set to zero), while Chain B was kept unchanged and used as reference. The Time was then transferred to Valladolid, (130km away) and compared against the GNSS time delivered using calibrated timing receiver, as presented in Figure 28.

#### 5.4.3 Time Generation

For the time generation demonstration, free-running Chain A (with the steering set to zero) was compared with Chain B, still steered to UTC(PTB). MTIE was 57 ns.

#### 5.4.4 Time Transfer Fibre

The tests were conducted in the Timing lab at GMV Newton near Madrid and evaluated WR link between the atomic clock server in the basement and the timing lab on the first floor of the GMV's building. The results, over 1 day, demonstrated nanosecond level time stability.

#### 5.4.5 Time Transfer Networks

Four tests were conducted – NTP FTTH, NTP VPN-IP, DTM MPLS and DTM FTTH. The first two failed and the remaining are reported below.

The test of DTM over MPLS (guaranteed bandwidth) was conducted in Germany over a link of 300 km. A stable time transfer has been observed, with the MTIE of 500 ns, with an average offset of 240 ns and 140 ns of standard deviation (jitter).

DTM over the Fiber To The Home (FTTH). was conducted in Spain over 130 km link between Madrid and Valladolid. The tests objective was to verify the performance on DTM over best effort bandwidth provision. The results shown that the time transfer was affected by various bias, increasing the standard deviation (jitter) up to 1 microsecond over a day and also introduced an offset, visualising as a sudden jump during the night. This large (and changing) offset is suspected effect of the network asymmetry and the changes in the internet network traffic. The effort to compensate for the offset using the GNSS receiver at the Valladolid site, were unsuccessful.

In summary, the test campaign results suggest that the time transfer accuracy heavy depends on the jitter and network asymmetry. The first factor is directly related to the intensity of the

internet traffic present in the used connection. This can be mitigated by increasing the packet rate to probe the delay more often, which require guaranteed amount of bandwidth. Practical experience indicates that requesting the right quality from the MPLS network is the critical and sufficient requirement for the below microsecond accuracy, though this can be expensive.

The results also suggest that calibration on “best effort network” using GNSS as time source is not enough to maintain a reliable service. Recommendations would be to focus on the DTM over MPLS for less-sensitive timing users and do not use other methods (i.e. link calibration using satellite-derived time), as they do not full-fill KPIs defined in section 3.2.

#### **5.4.6 Resilience**

The resilience test demonstrated the following:

- Fixed intervals monitoring of computer network (DTM and NTP protocols) time provision.
- GNSS independent time generation using PHM chain.

## 5.5 Satelles Inc

The Low Earth Orbit (LEO) consist of thousands of satellites transmitting from an operational altitude between 400 and 1,500 km (avoiding atmospheric drag and solar effects). The LEO orbit offers low latency and high received signal strength (30dB larger than from MEO orbit) at a low transmission power. In recent years, there has been a growing interest in using LEO constellations to provide more resilient PNT services.

Satelles offers the Satellite Time and Location (STL) PNT service relying on the Iridium LEO constellation, a precise ranging and timing signals. Satelles ground segment includes a dozen satellite monitoring and ground network sites with high-end atomic clocks for long-duration operation across the network. These allow the technology to be resilient to local or global GNSS denial or disruption events.

The platform provider has demonstrated:

- Generation and distribution, with mean difference of  $0.4\text{ns} \pm 132 \text{ ns}$ , for the prolonged periods of time without suffering outages and with few peaks, in the time provision both outdoor and indoor.
- Static position outdoor and indoor, within 10 m planar.

### 5.5.1 Key Performance Indicators (KPI's)

The timing key performance indicators are listed in Table 7, evaluated after 1, 14, and 100 days after GNSS outage. Timing results over 110 days fit very closely within normal distribution. Therefore Timing Accuracy to UTC (3 sigma) reported in table below was estimated using normal distribution and not MTIE. This excludes sporadic peaks discussed in section 5.5.3.

Positioning Performance KPI	Number of Days after GNSS Outage		
	1 day	14 days	100 days
Horizontal Accuracy (95%) m	17	17	17
Vertical Accuracy (95%) m	10	10	10
Availability (%)	100%	100%	100%
Continuity (per hour)	100%	100%	100%
Integrity (per hour)	N/A	N/A	N/A
Time To Alarm (second)	N/A	N/A	N/A
Timing Accuracy to UTC (3 sigma) ns	364	364	364
Time Stability (Allan Deviation)	$2.6\text{e-}12$	$2.1\text{e-}13$	$2.3\text{e-}13$
First time to provide services upon cold start-up (including system and receiver contributions)	<15min	<15min	<15min

Table 7. Performance indicators observed on the Satelles platform.

### 5.5.2 A-PNT Technology under Test

Both the timing and positioning tests were conducted at the JRC Ispra. Figure 29 shows the timing and static position setup, consisting of two independent receivers (primary Alpha and redundant

secondary Bravo). Each receiver was connected to its own antenna, monitored internally by their own Keysight 53230A TIC (1PPS) against UTC(IT) time provided by JRC and operated by its own local PC, accessible via secure connection.

Alpha, shown on the right hand side of the Figure 29, was used for 100 days, with the antenna placed on the roof, in the open sky conditions. Bravo, on the left hand side, was kept as a redundant spare and used in the indoor trials.

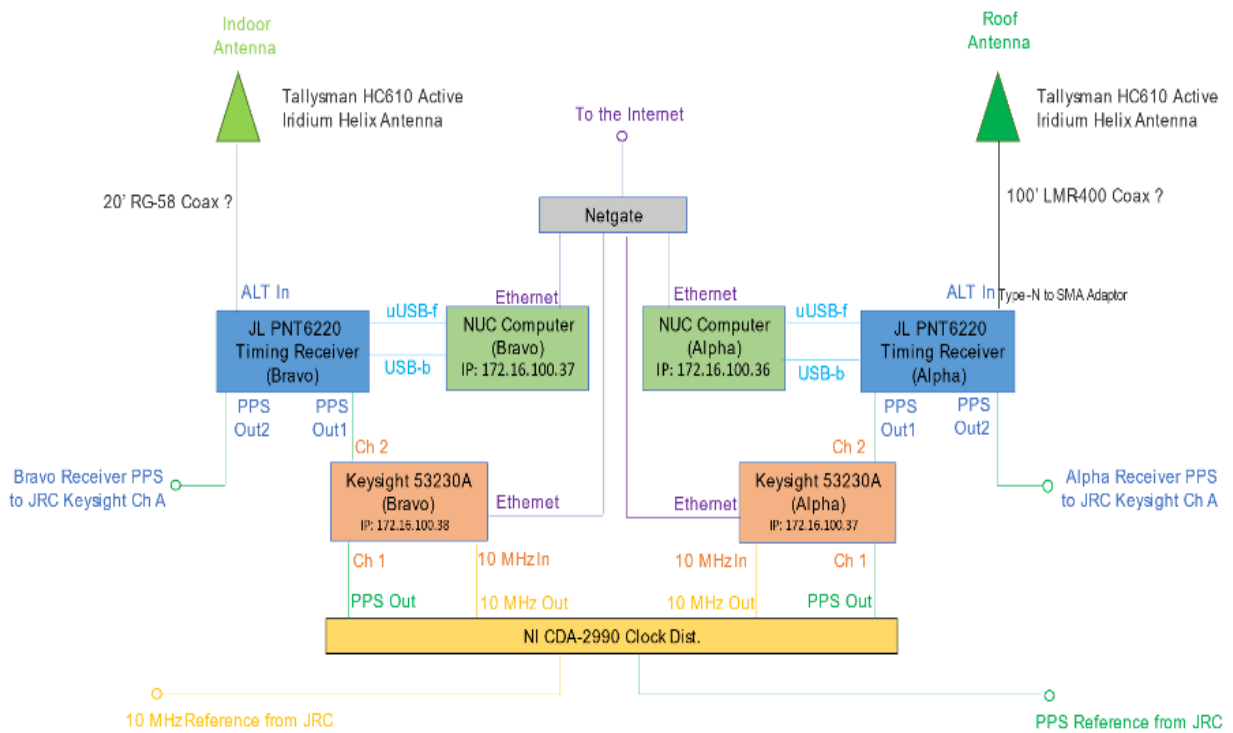

Figure 29. Logic layout of the PUT for timing and static trials of Satellites.

Figure 30 shows the test rig as deployed in the lab, with visible reference time (GNSS receiver and the atomic clock), two TICs (one to monitor the PUT and the other to monitor the time source against the additional atomic clock located in a different part of the lab), JRC monitoring PC and PUT with visible two TICs, two receivers and powered splitter that provided 1PPS from the JRC reference time to all TICs.

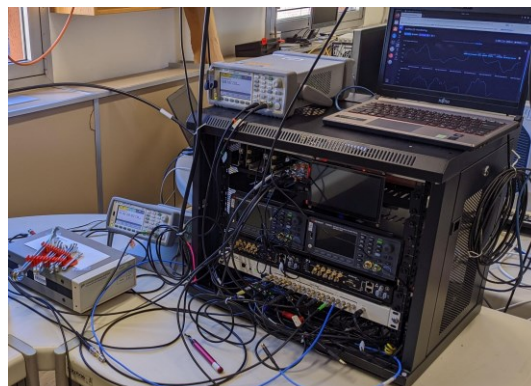

Figure 30. Timing test rig of Satelles as deployed in the JRC laboratory.

### 5.5.3 Time Generation and OTA time transfer

Satelles STL signal provides both time and position information. Its time is synchronised to *UTC(IT)*. To verify the accuracy of the time provision and distribution a roof-mounted antenna was installed at the pre-surveyed point on the roof of the JRC lab and the equipment was setup as described above.



Figure 31 Satelles antenna on the roof of one of the JRC laboratory.

As discussed in previous section an additional atomic clock, was used to monitor the JRC time source against UTC visualised in near-real time on the laptop (shown on top PUT in Figure 30). Both clocks provided *UTC(IT)* as described in Chapter 4.

Figure 32 shows the results of 101 days of data collection in red, and difference between the two JRC reference clocks in blue. Apart from occasional spikes, the results are stable and follow a normal distribution, with mean of 0.4 ns and standard deviation of 132 ns. The maximum observed peaks were 817 ns and 681 ns.

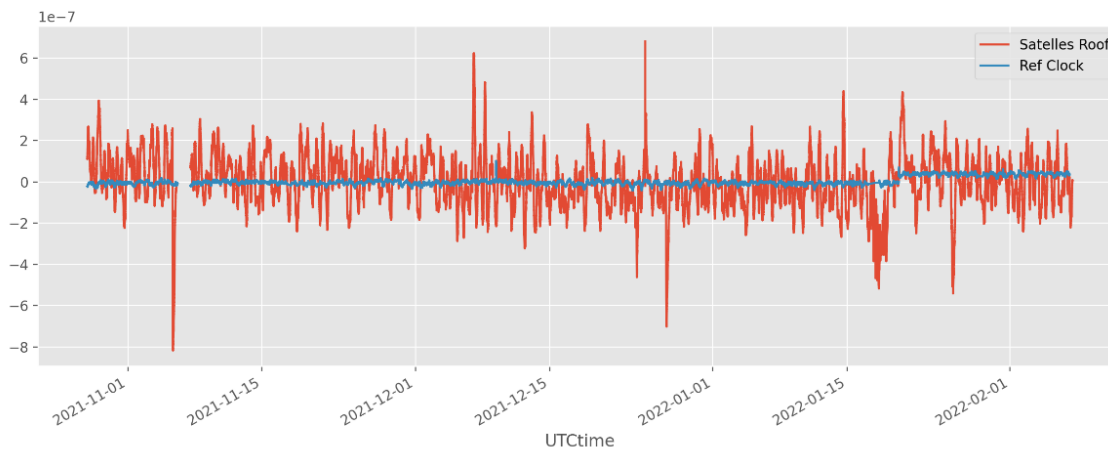

Figure 32 Results of 101 day of time generation and OTA test on the Satelles platform.

As can be seen in Figure 32, there are two non-continuities in the collected data, i.e.:

- A data gap can be observed in November'21. This was due to a data storage issue: indeed the data storage was not maintained, although all equipment was working correctly over the whole period as verified by the Satelles internal TICs.
- A data jump can be observed in January'22. This was due to a power outage in the testing lab, that led to the turning off of the reference time assembly and the Satelles receivers. A drift in the data can be observed until the reference time assembly atomic clock steers back to UTC.

All the observed data, including the drift, has been included in the statistics presented above.

#### **5.5.4 Time Transfer OTA Indoor**

The Bravo receiver was used for the indoor trials, with its antenna placed inside the lab, either on top or inside the metal cabinet, as shown in Figure 33. Severity of signal obstruction was verified by comparing the level of signal received.



Figure 33 Indoor testing, with antenna inside the metal cabinet, conducted on the Satelles Platform.

A total of four 24-hours static positioning tests were conducted at the JRC lab, with the results summarized in Table 8. More details can be found in [AD. 5].

Antenna location	MTIE (ns)
indoor antenna, on the top of the lab cabinet	25
indoor antenna, inside the metal lab cabinet	185
indoor antenna, on the top of the lab cabinet (repeat)	143
indoor antenna, inside the metal lab cabinet (repeat)	187

Table 8. 24-hours static positioning tests results on the Satelles platform.

### 5.5.5 Static Outdoor Positioning

As described in section 5.5.3, a STL antenna was placed on the roof, in open sky conditions. This point was pre-surveyed in ETRF coordinates, and seven days of static position data was collected.

As shown in Figure 34, the position results are affected by the orbit geometry, with latitudinal determination less precise than longitudinal one. Static 2D position accuracy is 17 m (95%).



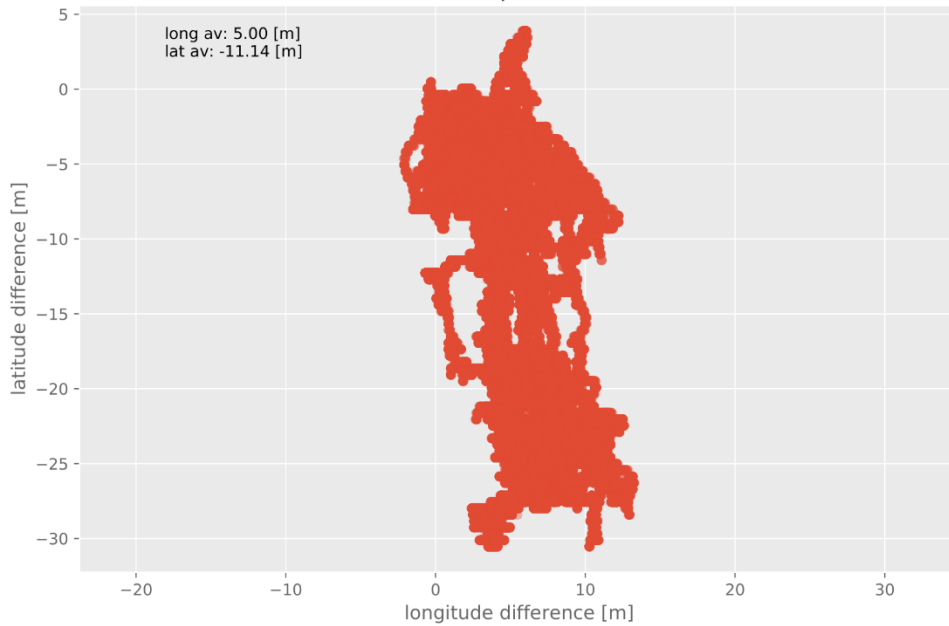

Figure 34. Results of the outdoor static tests performed over 7 days (starting collection on 10/28/2021 at 20:55) on the Satelles terminal.

### 5.5.6 Static Indoor Positioning

This test coincided with the Time Transfer OTA Indoor test, presented in section 5.5.4. The antenna was located on top and inside the metal cabinet as per Figure 33. Cabined was located roughly ( $\pm 1\text{m}$ ) underneath roof antenna position. Given the provided accuracy, the point location was not resurveyed.

A total of four 24-hour static positioning tests were conducted, which were:

Antenna location	2D error (95%) (m)
indoor antenna, on the top of the lab cabinet	15
indoor antenna, inside the metal lab cabinet	8
indoor antenna, on the top of the lab cabinet (repeat)	15
indoor antenna, inside the metal lab cabinet (repeat)	5

Table 9. 24-hours static positioning tests results.

### 5.5.7 Resilience

Satelles is the provider of the STL signal utilising the Iridium constellation. They demonstrated their ability to monitor the ground infrastructure, satellite status and signal in space, including log analysis capacity.

The ground segment redundancy includes servers, multiple network paths and failover between Iridium ground stations and STL application service. The virtualisation in the hot backup site requires approximately 100 ms for critical services and up to 2 minutes for the remaining ones to be back online.

Satellites control the transfer of their data payload on the Iridium spot beams. The Regional Controller (shown in Figure 35) provides monitoring, prediction, and beam control - enabling or limiting geographical access to STL. During the demonstration those changes were executed within 10 minutes of order entry.

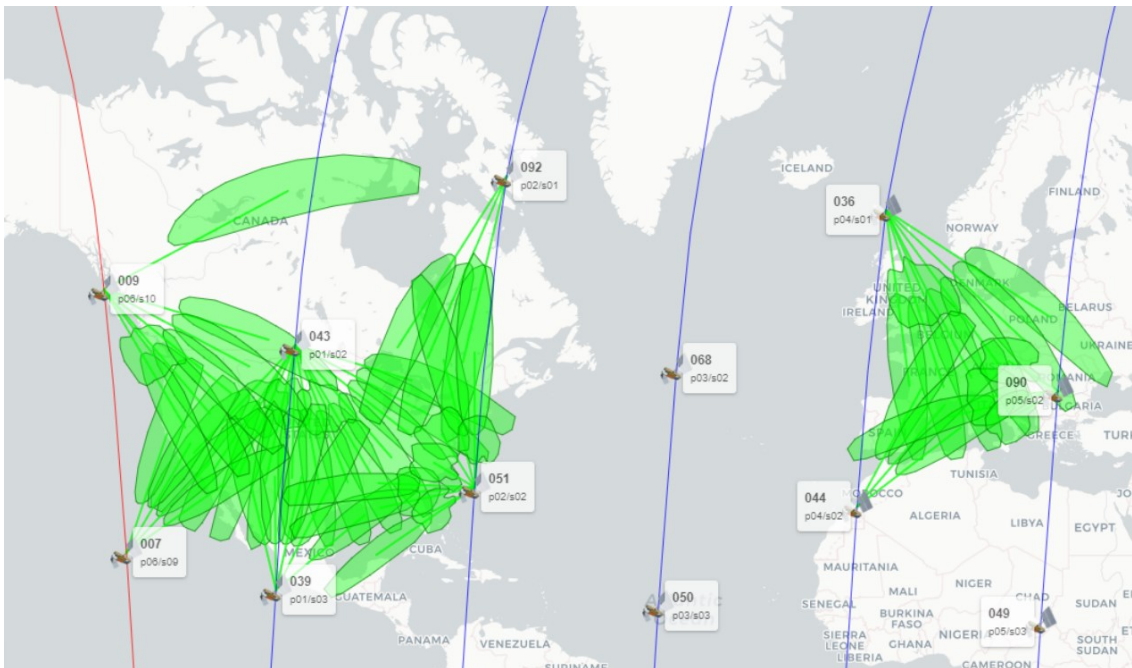

Figure 35. The Regional Controller's live tracking of the Iridium satellites spot beams.

## 5.6 Locata Corporation Pty Ltd

Pseudolites are a radio-based terrestrial positioning technology, employing a network of ground-based transmitters to estimate position using a radio-positioning signal within a specific area. The Locata network is internally synchronised using a proprietary Time Lock Loop (TLL) methodology trademarked as TimeLoc™ (i.e. the network does not require an external time reference such as an atomic clock to deliver high-accuracy position and synchronization within its' transmitted coverage area). The TimeLoc technology provides internal synchronization at the nano-second level to provide both positioning and time transfer. In all conducted tests, Locata transmitted a proprietary signal in the globally-available and open-access 2.4 GHz WiFi frequency band, at 20 dBm of power (EIRP).

Locata technology creates terrestrial networks (called LocataNets) of Locata transceivers (called LocataLites) which replicate the functionality of space-based GNSS satellite constellations. Any terrestrial positioning technology faces performance challenges caused by multipath, the near-far effect and the tropospheric delay, among other limiting factors. Locata demonstrated that they can limit or remove all these effects using spatial and frequency separated signals, pulsing schemes and their proprietary multipath mitigating beamforming antennas (called a VRay™ Orb antenna). Their technology was able to deliver the same positioning and timing accuracy outdoors as well as in multipath-rich environments like urban canyons and indoor environments.

### 5.6.1 Key Performance Indicators (KPI's)

The positioning and timing key performance indicators are listed in Table 10 and Table 11, respectively.

Positioning Performance KPI	Number of Days after GNSS Outage		
	1 day	14 days	100 days
Horizontal Accuracy (95%) m	0.017	0.017	0.017
Vertical Accuracy (95%) m	0.024	0.024	0.024
Availability (%)	100%	99.9999%	99.9999%
Continuity (per hour)	100%	99.9999%	99.9999%
Integrity (per hour)	1	$1 - 1 \times 10^{-7}$	$1 - 1 \times 10^{-7}$
Time To Alarm (second)	0.2 sec	0.2 sec	0.2 sec
First time to provide services upon cold start-up (including system and receiver contributions)	150 sec	150 sec	150 sec

Table 10. Positioning performance indicators observed on the Locata platform.

During testing Locata demonstrated:

- Nanosecond synchronisation accuracy to UTC time and time transfer outdoor, indoor and through non-line-of-sight obstructions like brick walls;
- Indoor and outdoor positioning at the cm-level, using their high-precision survey-grade carrier-phase solutions. These demonstrations included hardware and software multipath mitigation.
  - The average Locata outdoor positioning performance was 11 mm static and 10 mm RMS while kinematic, with 4 mm and 5 mm of standard deviation respectively.

- The average Locata indoor position performance was 8 mm static and 5 mm kinematic, with 5 mm and 4 mm standard deviation respectively.
- During the indoor tests, the technology was also configured to demonstrate alternative lower-precision meter-level code solutions and decimetre-level angle-of-arrival solutions;
- Reliability and resilience of the Locata network, matching safety-of-life level certification;
- Despite using only low power of 20 dBm EIRP (100 mW) transmissions, Locata demonstrated 105 km OTA time transfer. This range could be extended if a dedicated location frequency band could be introduced in Europe, as discussed in section 5.7.

Locata Timing Performance Parameters	Number of Days after GNSS Outage		
	1 day Demonstrated @ JRC	14 days (Projected)	100 days (Projected)
Availability (%)	100	99.9999	99.9999
Continuity (per hour)	1	$1 - 1 \times 10^{-8}$	$1 - 1 \times 10^{-8}$
Integrity (per hour)	1	$1 - 1 \times 10^{-7}$	$1 - 1 \times 10^{-7}$
Time To Alert (second)	1	1	1
Timing Accuracy to UTC (3 sigma)	1.7 ns + Accuracy Of Chosen External Time Standard		
Timing Accuracy Internal (3 sigma)	150 ps	150 ps	150 ps
Time Synchronization (Allan Deviation)			
- Internal Synchronization	$3 \times 10^{-15}$	same	same
- External Synchronization	$4 \times 10^{-14}$		
Timing Stability (Allan Deviation)	$4 \times 10^{-14}$ + Stability of Chosen External Time Standard		
First time to provide services upon cold start	5 minutes per TimeLoc Hop		

Table 11. Timing performance indicators observed on the Locata platform.

### 5.6.2 A-PNT Technology under Test

Locata has demonstrated both timing and positioning capabilities at the JRC Ispra site, and positioning capabilities at a Düsseldorf site. JRC deployed both timing and positioning references for each platform. Two separate timing setups were deployed at the JRC premises, and two separate positioning setups, one at the JRC and one at Düsseldorf. The following subsections summarise the main components of all the setups, while further details are included in [AD. 6].

### 5.6.3 Timing Setup

The laboratory setup in JRC Building 72C consisted of two LocataLites (JRC-1 and JRC-2), as shown in Figure 36. LocataLite JRC-1 acted as master and was connected to the Locata time source while LocataLite JRC-2 acted as the End-Node (end user) and this is where transmission accuracy was measured. LocataLite signals were broadcast using ‘cube’ antennas mounted on the roof of the laboratory for outdoor local area and wide area tests. Locata synchronised internally between LocataLites, and externally between Master LocataLite and the Locata time source. The internal and external synchronization, along with the stability of the Locata time source against the JRC UTC Reference, were measured using Time Interval Counters (TICs). TIC1 compared the internal synchronisation of End-Node LocataLite JRC-2 against LocataLite JRC-1; TIC2 compared Locata time source against JRC UTC Reference; and TIC3 compared End-Node LocataLite JRC-2 against JRC UTC Reference.

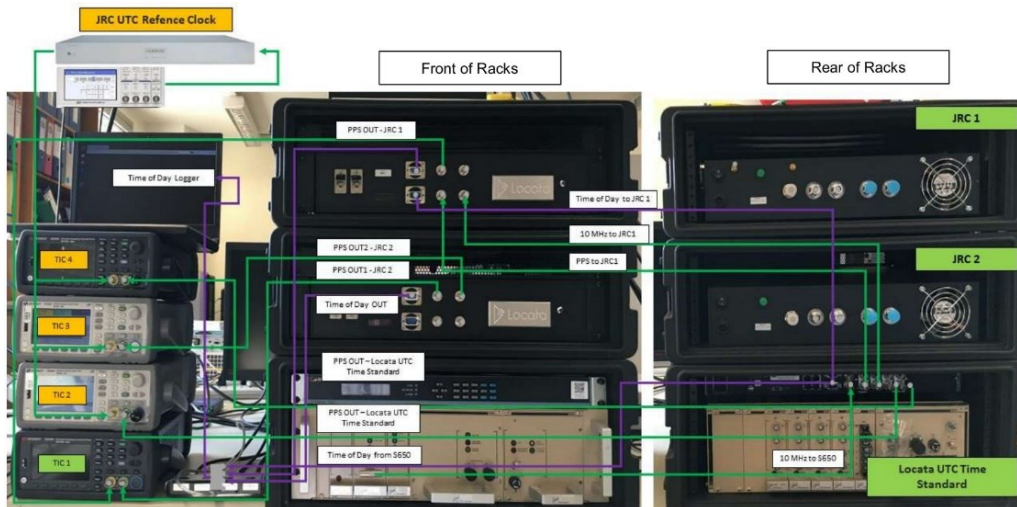

Figure 36 Laboratory setup used to assess the performance of the Locata platform.

The outdoor tests consisted of multiple LocataLite TimeLoc hops with the measurements also taken at the End-Node LocataLite JRC-2. Two configurations were used:

- Local area tests were conducted between Building 72C (Laboratory), Building 48 (Workshop) and Building 77 (Tower), all within the JRC campus. The test comprised five LocataLites and four TimeLoc hops giving a total time transfer distance of approximately 2 km. Timing signals were propagated from Master LocataLite JRC-1, via Workshop-1, and onto Tower-1. Using a 'bent-pipe' configuration Tower-1 then returned the timing signals to Workshop-2 and back to the End-Node LocataLite JRC-2, as shown in Figure 37.

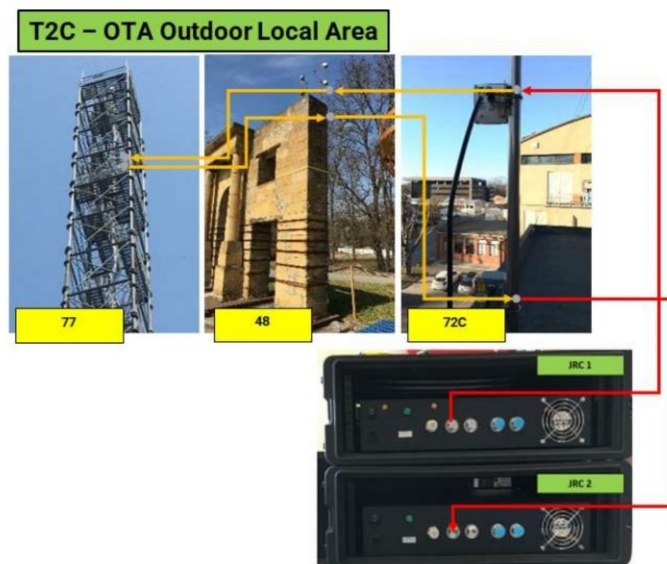

Figure 37 Local area timing setup used in the tests with Locata.

- The wide area setup comprised a total of nine LocataLites and eight TimeLoc hops. The setup included the three JRC sites from the local area setup plus two additional sites at Massino Visconti and Como Brunate. Massino Visconti is situated 8 km west of the JRC across the other side of Lake Maggiore, while Como Brunate is situated 44 km to the east

of Massino Visconti. This extended the time transfer ‘bent-pipe’ distance to 105 km. LocataLites situated at Massino Visconti were named after the nearby mountain ‘Mottarone’, while the LocataLite at Como Brunate was named after the nearby township of ‘Como’. A mixture of different antenna types were used. LocataLites at Como Brunate, Massino Visconti and Tower used ‘dish’ antennas while the remaining sites used the same ‘cube’ antennas as in the laboratory set-up. The whole layout is shown in Figure 38.

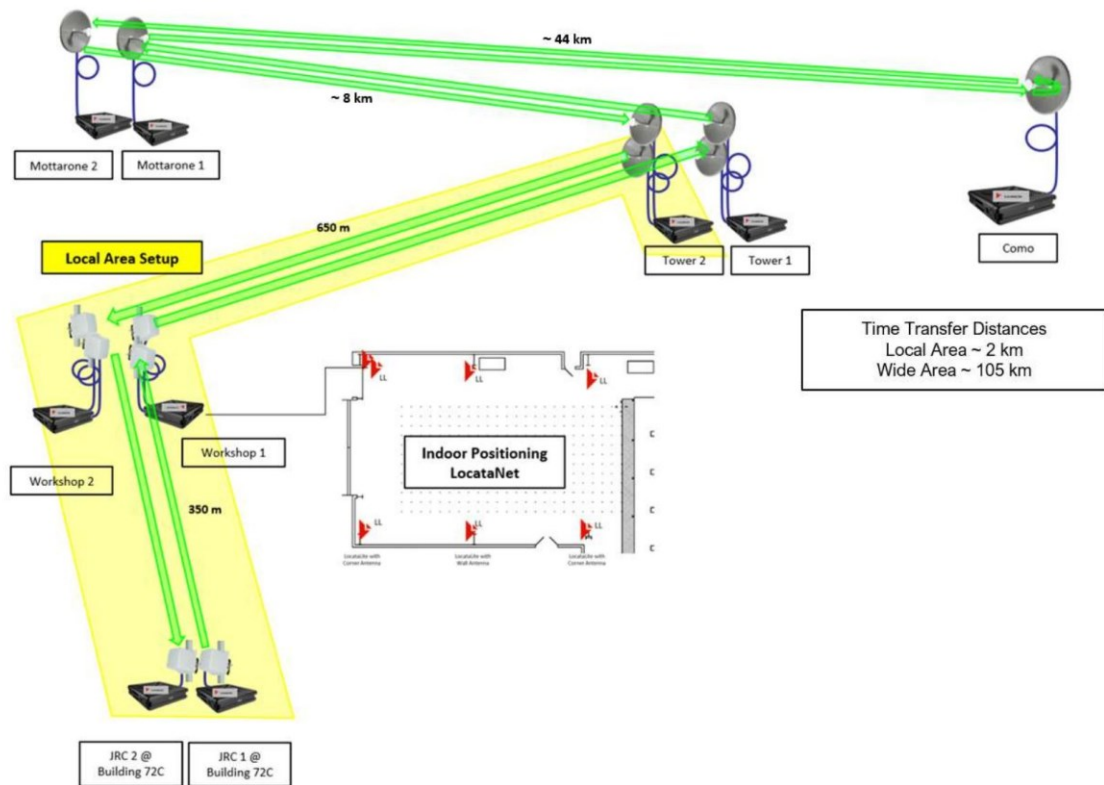

Figure 38 Layout for the wide area test, showing both Local Area and Wide Area setup used by Locata.

### 5.6.4 Positioning Setup

Positioning tests were split between two locations:

- Indoor tests were conducted in a multipath-rich indoor space in JRC Building 48 (Workshop). This required preparations described in section 4.3;
- Outdoor tests were conducted in a Konecranes industrial test facility in Düsseldorf, Germany. It has a permanent deployment of 7 LocataLites, mounted approximately 22 m above ground level, as shown in Figure 39.





Figure 39. Locata outdoor network setup in Düsseldorf.

The indoor demonstration consisted of a network of pre-surveyed points, shown in Figure 10. A survey prism was installed on top of the VRay Orb antenna, allowing Total Station to track the prism as a positioning truth reference, as shown in Figure 12.

The outdoor demonstration in Düsseldorf focused on Locata's navigation capacity deployed on a Konecranes' fully-autonomous A-Strad port container-moving machine (shown in Figure 40). Each A-Strad had two Locata Rovers, one positioned at either end of the machine, with each Rover connected to a Locata VRay multipath-mitigating Orb antenna. This dual Rover and VRay configuration allowed the A-Strad to precisely determine the position and orientation of the machine. To verify the Locata position solution accuracy the test setup also included Total Station and GNSS reference systems. A 360° survey prism and GNSS antenna were mounted co-centrally on top of Orb 1, as shown in Figure 40. These reference systems were used to cross-check the independently reported Locata position solutions.

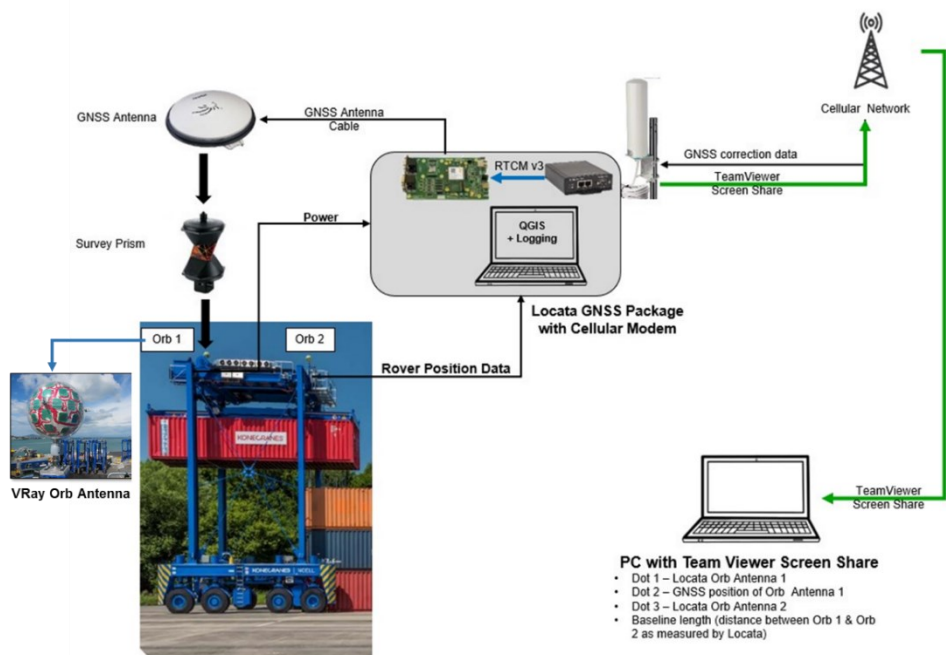

Figure 40. A-Strad test setup of Locata installation in Düsseldorf.

The reference GNSS position was established using the German network RTK (NRTK) service, providing cm level reference within ETRF. The Total Station was set-up using two pre-surveyed points (established using the same GNSS setup), hence maintaining the same ETRF. It should be noted that reported accuracy was matching the one of reference system GNSS, hence the additional use of a Total Station as a further truth reference system.

### 5.6.5 Time Generation

Locata discussed the options of deploying time generation within the network. During JRC tests, Locata deployed a *Microchip SyncServer S650* as a time source for Locata UTC, providing also time holdover capacity. For the holdover demonstration, the SyncServer S650 was synchronized to UTC via GNSS and then placed into holdover disciplined from a Ball Efratom MRK Rubidium time standard. The Locata to UTC Comparison was heavily influenced by the performance of this Rubidium time standard. Equipment was tested during Time Transfer Networks, OTA Indoor and OTA Outdoor tests, and demonstrated capacity to provide time, within KPI specification, beyond one day (exceeding 24 hours).

### 5.6.6 Time Transfer Reporting

Given the nature of Locata TimeLoc synchronisation, time transfer results are reported as:

- Locata Internal Time Transfer: This value is measured as the difference between Master LocataLite (JRC-1) and the End-Node LocataLite (JRC-2).
- Locata External Time Transfer: This value is measured as the difference between the Locata UTC Time Standard (S650) and the End-Node LocataLite (JRC-2).
- Locata to UTC Comparison: This value is measured as the difference between the JRC UTC Reference (FS740) and the End-Node LocataLite (JRC-2). Those are not reported below, as it includes clock drift from S650 and as such not representative of time transfer. Values can be found in [AD. 6], on p. 68.

### 5.6.7 Time Transfer Fibre

This test was conducted at the JRC Building 72C laboratory, a 1 kilometre length of single-mode fibre line connected Master LocataLite JRC-1 and End-Node LocataLite JRC-2.

Results as reported in [AD. 6] show sub-nanosecond accuracy for Locata Internal and External Time Transfer, and hundred nanosecond level accuracy for Locata to UTC Comparison running in holdover with the Rubidium time standard.

Internal Time Transfer			External Time Transfer		
Mean [ns]	Peak-to-Peak [ns]	Std-Dev [ns]	Mean [ns]	Peak-to-Peak [ns]	Std-Dev [ns]
0.21	0.40	0.04	0.1	4.9	0.5

Table 12. Time Transfer Fibre results on the Locata platform.

### 5.6.8 Time Transfer Networks

This test was conducted at the JRC Building 72C laboratory, a 50 metre length of LMR400UF coax cable connected Master LocataLite JRC-1 and End-Node LocataLite JRC-2. Results as reported in



[AD. 6], show sub-nanosecond accuracy for Locata Internal and External Time Transfer, and hundred nanosecond level accuracy for Locata to UTC Comparison running in holdover with the Rubidium time standard.

Internal Time Transfer			External Time Transfer		
Mean [ns]	Peak-to-Peak [ns]	Std-Dev [ns]	Mean [ns]	Peak-to-Peak [ns]	Std-Dev [ns]
0.07	0.41	0.05	0.1	6.1	0.5

Table 13. Time Transfer Networks results

### 5.6.9 Time Transfer OTA Outdoor

The time transfer OTA Outdoor tests involved locations across several buildings and structures at the JRC site and two locations outside of the JRC. The tests included three independent set-ups:

- **OTA Outdoor Local Area:** In this setup the Master LocataLite JRC-1 timing signal was transferred via LocataLite Workshop-1 to LocataLite Tower-1. This location returned the timing signal in a ‘bent-pipe’ configuration back to LocataLite Workshop-2 and onto End-Node LocataLite JRC-2, co-located with JRC-1. All LocataLites, utilized ‘cube’ antennas apart from Tower-1, which used a ‘dish’ antenna. This demonstrated four TimeLoc ‘hops’ covering approximately 2 km.
- **OTA Outdoor Wide Area:** This setup extended the Local Area test LocataNet by adding two sites outside of the JRC (Massino Visconti and Como Brunate). This test demonstrated eight TimeLoc ‘hops’ with a total length of 105 km. The LocataLites on Tower and those outside JRC had ‘dish’ antennas deployed, while the remaining LocataLites had ‘cube’ antennas. During the tests, tropospheric adjustments were autonomously calculated and applied continuously, in real time, by each LocataLite independent of any external meteorological input.
- **Sub-network:** In this case the Wide Area network acted as a ‘backbone’ timing source, providing UTC timing signals via LocataLite Workshop-1 into indoor sub-network LocataLites. The sub-network LocataLites were subsequently used for indoor position and timing tests. The values reported in the Sub-network (Indoor Workshop) indicate the difference between the indoor Rover producing a PVT (position, velocity and time) solution and the Workshop-1 LocataLite.

The results summarized in Table 14 show sub-nanosecond accuracy for Locata Internal and External Time Transfer. Further results as reported in [AD. 6] show hundred nanosecond level accuracy for Locata to UTC Comparison running in holdover with the Rubidium time standard. The holdover function was active for all tests, with the exception of the Sub-network test.

	Internal Time Transfer (ns)			External Time Transfer (ns)		
	Mean	Peak-to-Peak	Std-Dev	Mean	Peak-to-Peak	Std-Dev
OTA Outdoor Local Area (2 km)	0.07	0.41	0.05	0.1	6.1	0.6
OTA Outdoor Wide Area (105 km)	0.58	0.75	0.08	0.4	6.1	0.5
OTA Sub-network (Time transfer to Indoor Rover)	1.2	3.3	0.75	-	-	-

Table 14. Time transfer performances in the OTA outdoor tests made by Locata.

### 5.6.10 Time Transfer OTA Indoor

Conducted in and around the JRC Building 72C laboratory, these tests demonstrated short range time transfer, using ‘cube’ antennas connected to Master LocataLite JRC-1 and End-Node LocataLite JRC-2. Testing included two independent arrangements:

- OTA Indoor, with both antennas located inside the building.
- OTA Outdoor-to-Indoor, with one antenna mounted approximately 20m outside the building and the other antenna mounted inside the laboratory. The outdoor antenna was connected to Master LocataLite JRC-1 and the indoor antenna connected to End-Node LocataLite JRC-2. The non-line-of-sight path required the Locata signal to penetrate through the eastern brick wall of Building 72C and a stacked bookcase situated within the laboratory.

Results, as reported in [AD. 6], show sub-nanosecond accuracy for Locata Internal and External Time Transfer, and hundred nanosecond level accuracy for Locata to UTC Comparison running in holdover with the Rubidium time standard.

	Internal Time Transfer (ns)			External Time Transfer (ns)		
	Mean	Peak-to-Peak	Std-Dev	Mean	Peak-to-Peak	Std-Dev
OTA Indoor to Indoor	0.17	0.29	0.03	0.17	5.2	0.6
OTA Outdoor to Indoor	0.55	0.32	0.04	0.63	5.5	0.6

Table 15. Time transfer performances in the OTA indoor tests made by Locata.

### 5.6.11 Static Outdoor Positioning

This test was conducted in Düsseldorf. Test tracks, described in the kinematic section, included multiple static points, measured in real-time by Locata, GNSS and a Total Station. Tests were fully-autonomous and A-Strads were programmed to repeat each test track two to three times.

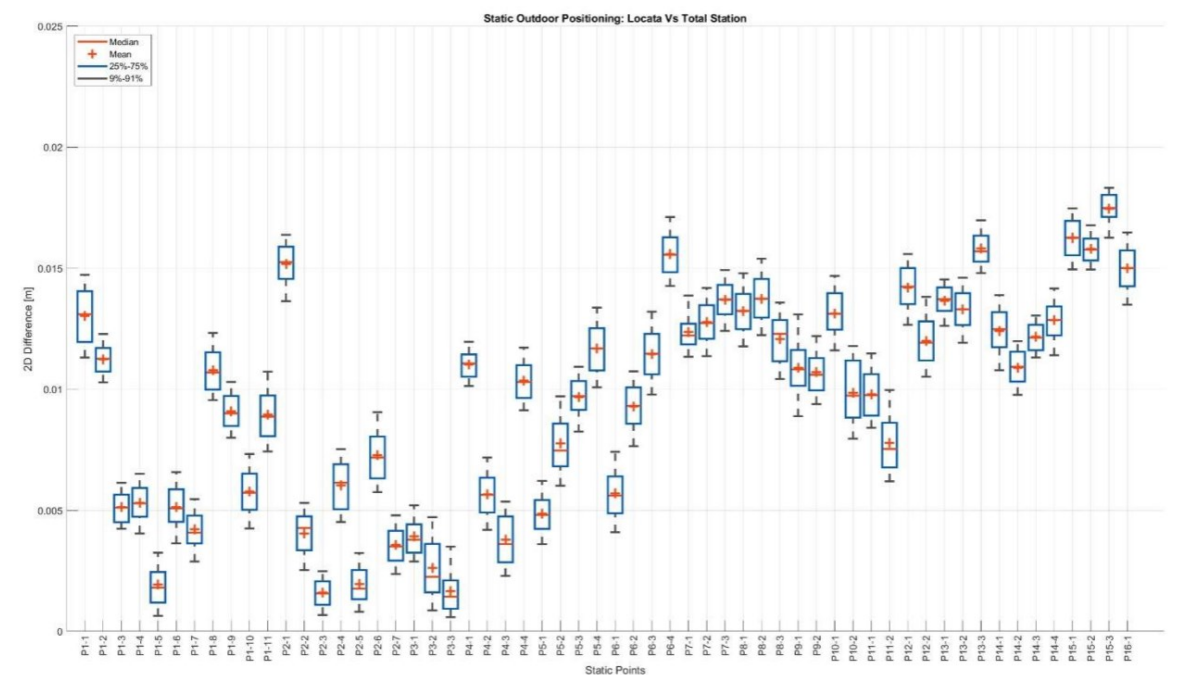

Figure 41. Static outdoor positioning errors (boxplot) observed on the Locata platform.

Figure 41 shows the *boxplot* for all the surveyed locations (shown in Figure 44). Points are labelled as Pxx-y where xx is the point number and y is the occupation identifier. The average Locata indoor 2D position was within 0.013 m (95% of the time). The difference shown is that between Locata’s generated positions and the Total Station measurements.

### 5.6.12 Static Indoor Positioning



Figure 42. Test setup environment used by Locata in the indoor positioning tests.

This test was conducted inside Building 48 (Workshop) at the JRC Ispra. 23 pre-surveyed points, placed on an arrangement grid of 4x6 (shown in Figure 10), were used. The Rover (visible in Figure 12) occupied the same subset of points (20, 19, 14, 13, 6, 3, and 23) twice.

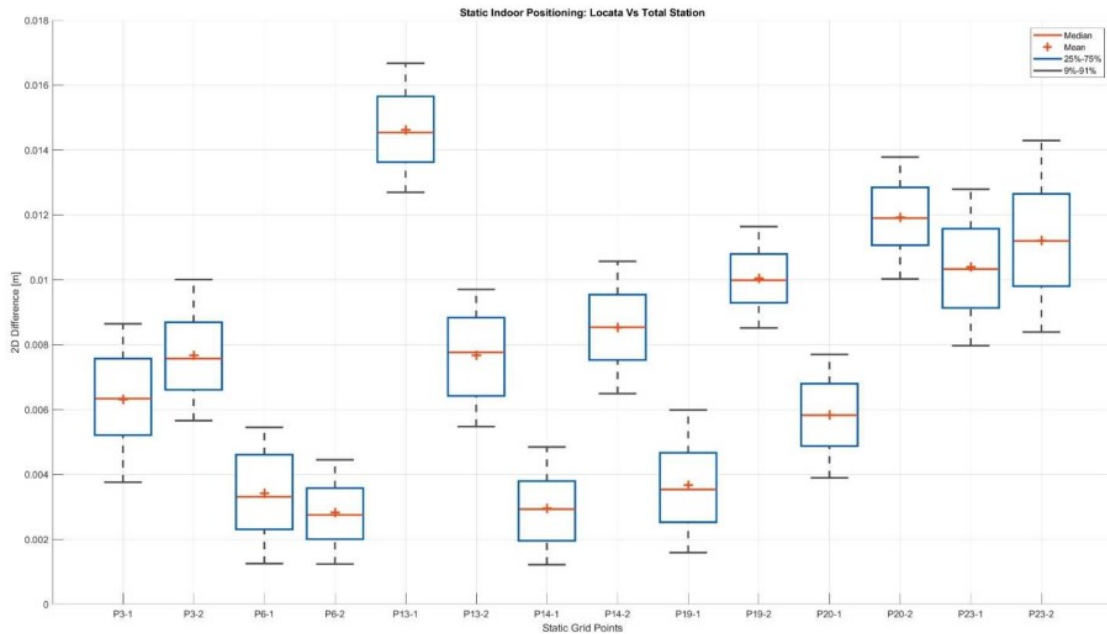

Figure 43. Static indoor positioning errors (boxplot) observed on the Locata platform.

Figure 43 shows the results for indoor positioning tests, with the same labelling methodology as Figure 41. The average Locata indoor 2D position was within 0.013 m (95% of the time).

### 5.6.13 Kinematic Outdoor Positioning

Figure 44 shows a plan view of the Konecranes LocataNet with the A-Strad travel-lane centrelines indicated in the figure by a dashed line. Those were programmed for A-Strads to travel along, and to perform 90° or 180° turns, subject to the A-Strads' minimum turn radius.

A total of six routes were all autonomously driven, and each one has been repeated two to four times. Routes were driven in between the static occupations shown in Figure 45. In detail:

- The first route was driven from point P4 to P1 and return with stops for static data collection at points P2 and P3. This route was repeated four times.
- The second route was driven from point P5 to P6 and return and was repeated three times.
- The third route was driven from point P7 to point P8 stopping at P9, repeated twice.
- The fourth route was driven in a loop starting from point P12 and going through P10 and P11, and repeated twice.
- The fifth route was driven from point P1 to P13, repeating three times.
- The sixth route was driven from point P14 to P15 and return, repeating three times.
- Data collection finished at point P16.



Figure 44. A plan view of the Konecranes LocataNet (not to North) installation.

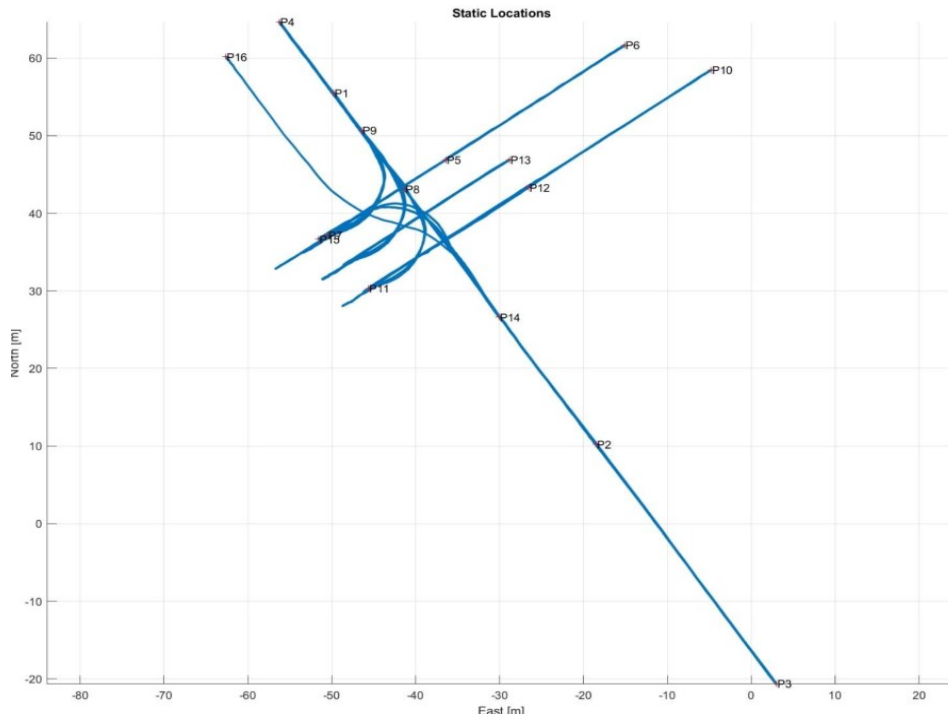

Figure 45. Kinematic test track from the Konecranes LocataNet installation.

The resulting cumulative distribution function (CDF) plot, shown in Figure 46, is the 2D difference between the Locata Rover and the GNSS. The Locata 2D positioning accuracy was within 18 mm 95% of the time. Note that at approximately 10:34am the system recorded a 2D difference spike of 0.033m, which was included in those statistics.

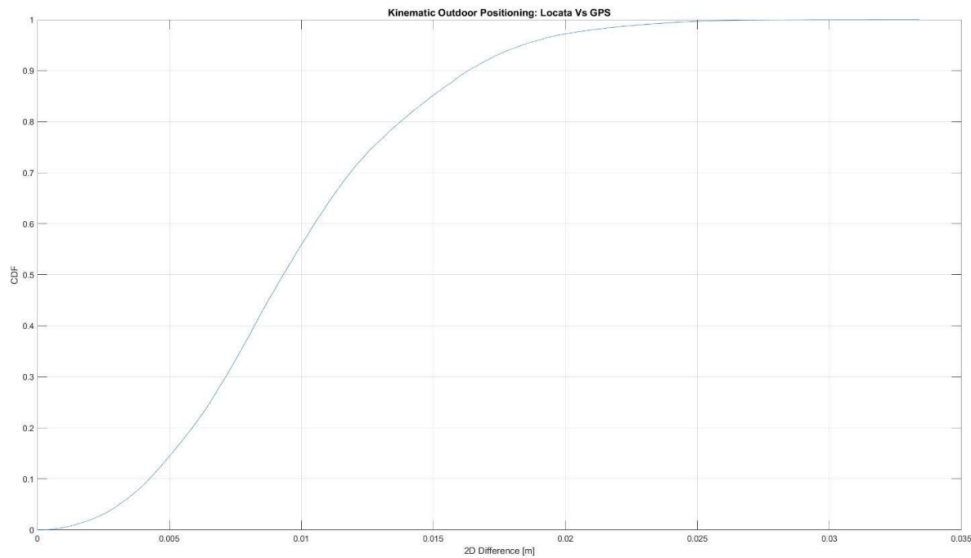

Figure 46. CDF for the Outdoor Kinematic Test from the Konecranes LocataNet installation.

#### 5.6.14 Kinematic Indoor Positioning

This test was conducted inside BG48 (Workshop) at the JRC Ispra and consisted of two tests:

- During the first, the Locata Rover was moving in a repeated pattern in an East-West direction, as shown in Figure 47;

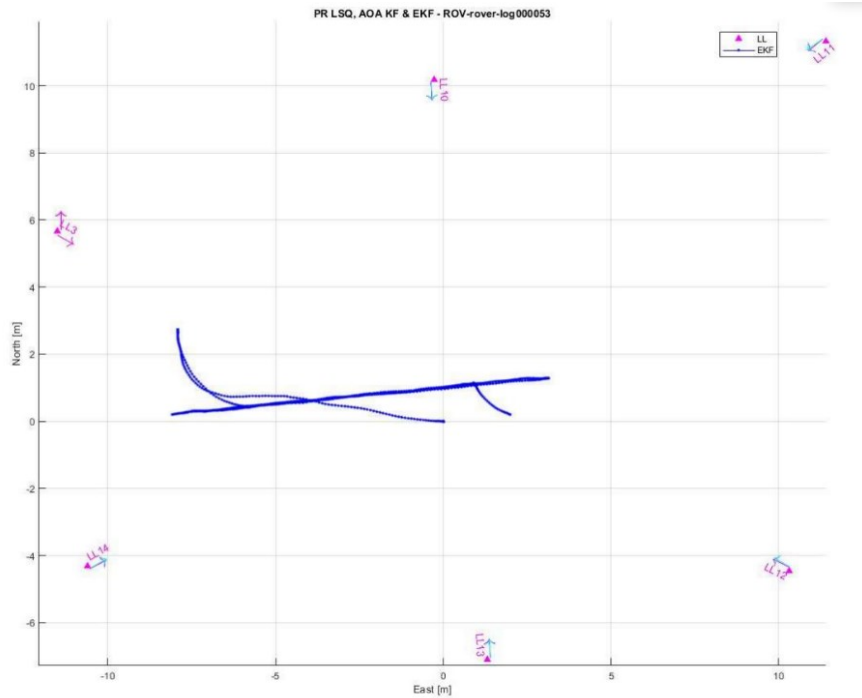

Figure 47 The path of the kinematic indoor 1st trial from the indoor tests with Locata.

- During the second trial the Rover was moved in a repeated pattern forming a shape of a cross, as shown in Figure 48.

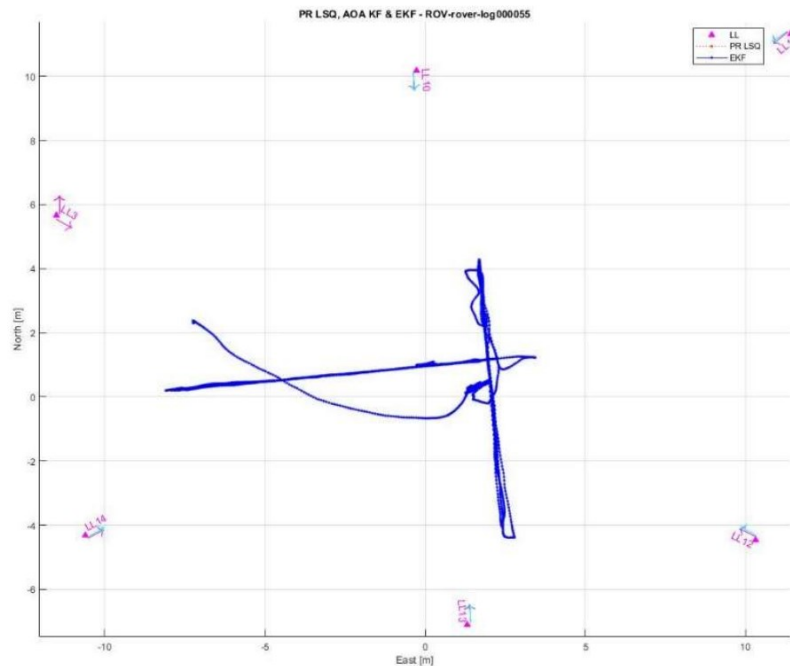

Figure 48 The path of the kinematic indoor 2nd trial from the indoor tests with Locata.

The position was continuously tracked using a robotic Total Station, which had an update rate that is different from that of the Locata Rover (10Hz). While the Locata Rover was synchronized

to the UTC time via the Locata 'backbone', the Total Station could not be. Given the time scale differences, as well as the asynchronous sampling rate, the difference was calculated following the next steps:

1. The approximate time alignment of the Total Station and Locata Rover was first determined by minimising position differences;
2. Total Station points were projected to the Locata Rover's trajectory;
3. Difference between the points were calculated, reducing difference to cross-track component only

Results of the test are presented in Figure 49 and Figure 50. Both show the CDF of the 2D difference between the position estimated by the Locata Rover and that evaluated by the total station, obtained by following the algorithm described above. Accuracy is within 11 mm, 95% of the time.

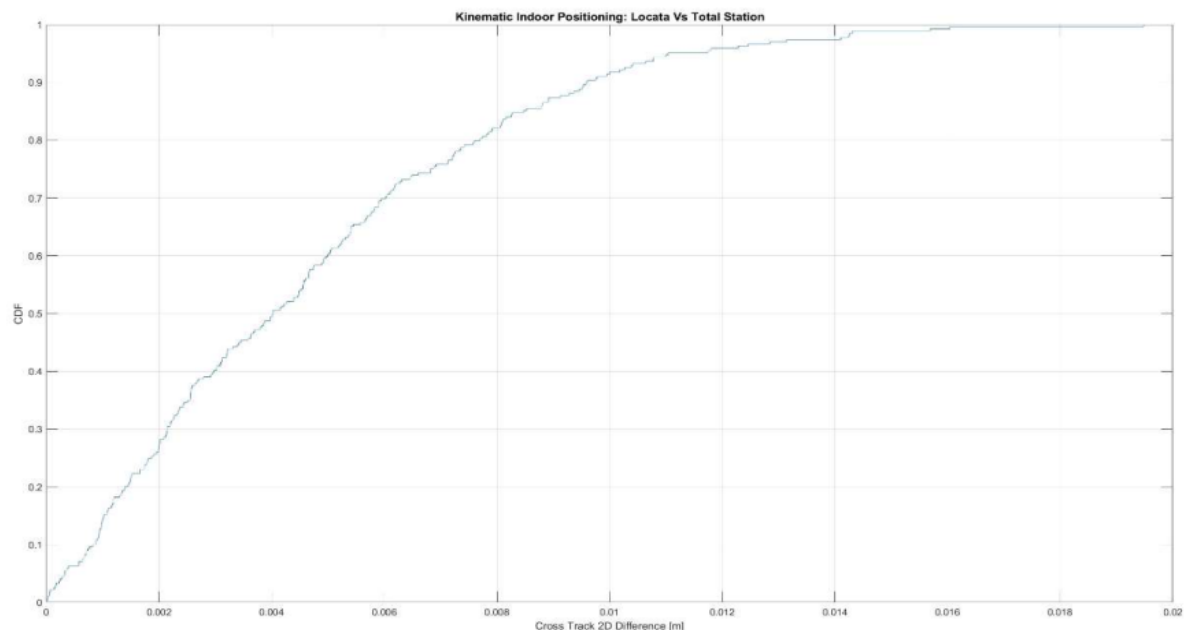

Figure 49 CDF for the Indoor Kinematic Test 1 from the indoor tests with Locata.



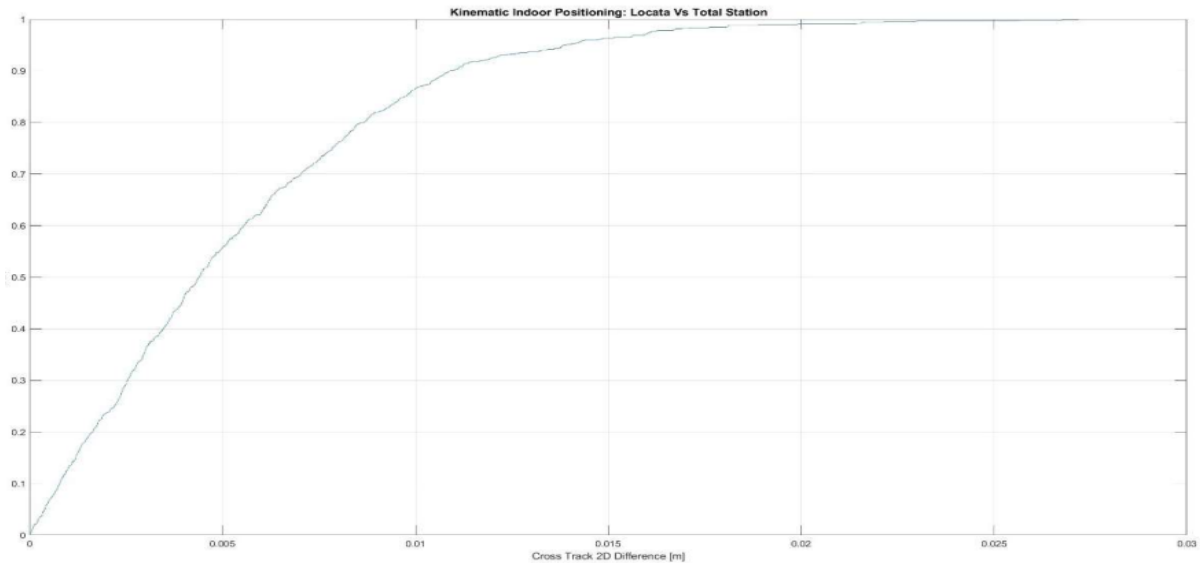

Figure 50 CDF for the Indoor Kinematic Test 2 from the indoor tests with Locata.

### 5.6.15 Resilience

LocataLites and Locata Rovers are operating in harsh industrial and critical safety-of-life autonomous machine applications (such as the Dusseldorf Konecranes Development Test Site above), conforming to EU's EN ISO 13849 Standard for Safety of Machines. These environments, however, also limit frequent physical access to the remotely deployed system hardware. The conducted tests demonstrated this resilience capacity by:

- Demonstrating remote real-time monitoring of the LocataNet, including remote access to every unit;
- TimeLoc Bracing, which assigns multiple reference LocataLites to each LocataLite in the network. In this way if a line-of-sight or a reference LocataLite is lost, the network still remains continuously synchronised.
- Dual Master refers to a LocataNet setup, where one LocataLite is designated as a Secondary (Alternate) Master. This Alternate LocataLite will act as master in the event of a loss of the Primary Master LocataLite. To continuously provide time referenced to UTC also, a Secondary Master needs to be connected to a UTC source (otherwise the system will act in local/internal time mode).

## 5.7 NextNav LLC

TerraPoiNT is a Terrestrial Beacon System, as defined by the Third Generation Partnership Project (3GPP). It is a positioning technology based on a network of ground-based transmitters to trilaterate a position using a radio-positioning signal within a specific area. NextNav uses a dedicated band, i.e., from 921.8845 to 927.0000 MHz in the United States, but the system is relatively frequency flexible and can be deployed in other bands (e.g., 860 MHz is used by NextNav in Japan). The network is synchronised, with the Leader also deploying precise atomic clock oscillators, to provide position and time. All beacons may be optionally connected to a wireless backhaul network, providing telemetry information and are managed from a central Network Operations Centre (NOC), monitoring the whole network. Within the TerraPoiNT terrestrial network, the rover planar position is trilaterated using signals from 3 or more radio-positioning beacons. Height is estimated using the differential barometric technique.

NextNav is licensed to operate with a 920-928 MHz frequency band, which was established in the USA for the use of Location and Monitoring Service (LMS) (*FCC Part 90 subpart M*), to support transportation infrastructure and to facilitate the growth of Intelligent Transportation System. Its primary use are Industrial, Scientific, and Medical (ISM) (FCC Part 18) and unlicensed (FCC Part 15) devices. In Italy, that specific band is licensed to a mobile network operator and the *Italian Railways Network* GSM-R services. Tests, therefore, required permission from Italian Spectrum Regulator (*MISE*) and coordination of transmission from beacons with the licensed users. This limitation required some of the tests to be conducted in the US.

The summary presented focus predominantly on the tests conducted at the JRC, with shorter description of the US tests, as JRC personnel did not run those tests.

### 5.7.1 Key Performance Indicators

Performance Parameter (X days of GNSS outage)	1 day	14 days	100 days
Horizontal Accuracy (95%) m	11	11	11
Vertical Accuracy (95%) m	2	2	2
Availability (%)	99.96%	99.96%	99.96%
Continuity (per hour)	99.93%	99.93%	99.93%
Integrity (per hour)	100%	100%	100%
Time-To-Alarm (second)	60s	60s	60s
Network Timing Accuracy to UTC (3sigma) ns	9 =	120	900 =
Network Time synchronisation (ADEV)	9e-13	3e-14	3e-14
Network Timing Stability (ADEV)	4e-14	2e-14	2e-14
First time to provide services upon cold start-up (including system and receiver contributions)	10 sec (PN receiver only)		
	7 min (T-receiver only)		
	15 min (System + receiver T- only)		
	43 min (System + receiver: PN or T)		

Table 16. Summary of the performances at 1, 14, and 100 days of GNSS outage, observed with NextNav.

The positioning and timing key performance indicators are listed in Table 16, details can be found in [AD. 7].

Results have demonstrated:

- Time transfer network within 15 ns and within 40 ns to time source;
- Holdover capacity of the lead beacon;
- Outdoor kinematic (and static) 2D positioning within 11m and indoor static within 14m, both for 95% of the time. Height position, using differential barometric technique, was 1-2 meters 95% of the time.

### 5.7.2 A-PNT Technology under Test

The campaign was conducted in two locations:

- At the JRC Ispra site for timing and indoor z tests. Here, due to restrictions in terms of frequency allocations, weight and time, a smaller network, was deployed.
- In the US (San Jose California, SJC), where existing seven beacon network was used to run timing and positioning tests by. Further details are available in [AD. 7].

#### 5.7.2.1 JRC Ispra

The network deployed at the JRC consisted of three beacons, as shown in Figure 51. This setup allows to test the timing (using NextNav NTR receiver) and the indoor position (height component only).

### 3 Beacon Timing and Z only Network

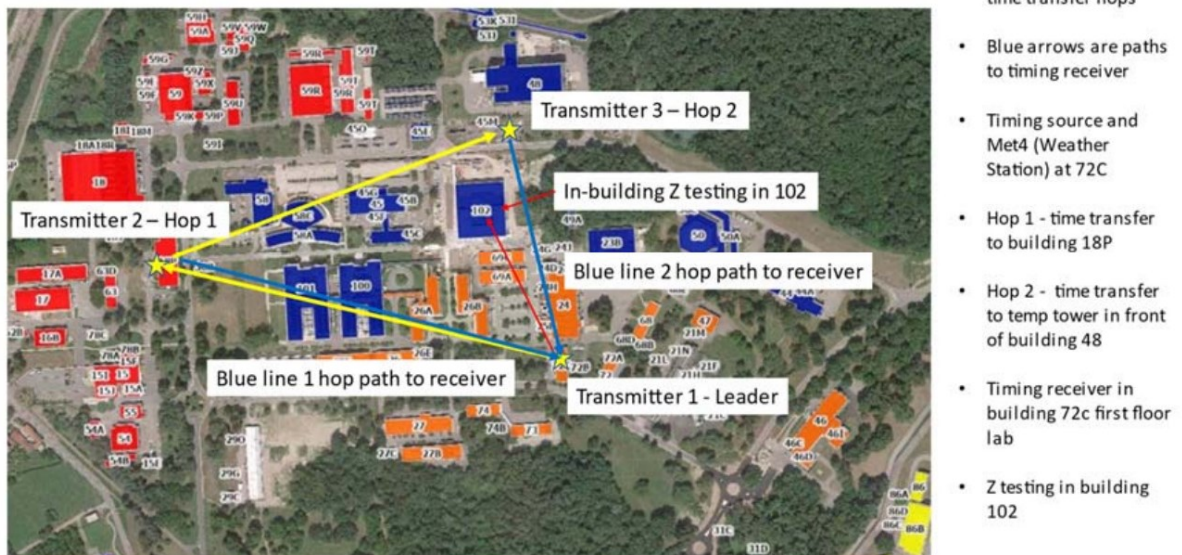

Figure 51. Beacon Timing and Z-only Network deployed at JRC for the performance assessment with NextNav.

To verify the timing the JRC testing rig, described in section 4.2, was used. The UTC source was also provided by JRC, while the positioning results were verified against pre-surveyed floor heights, as discussed in section 4.3.

### 5.7.2.2 San Jose California (SJC)



Figure 52. Beacon SJC-APNT network deployment of NextNav in San Jose (CA, USA).

The network, presented in Figure 52, composed by 7-beacon, and including the Leader beacon with Caesium clock, allowed to test both position and time using positioning (LPRx) and timing (NTR) receivers, respectively. The network relied on the network operating in GNSS-free mode 15 days prior to the tests. To verify the timing results, NextNav used the test rig based on [Calnex synchronization tester](#). As shown in Figure 53, UTC time was obtained via GPS and compared against the incoming PPS pulse.

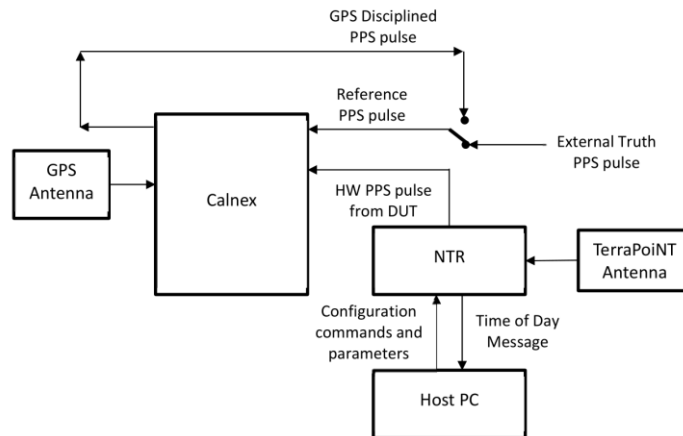

Figure 53. Timing Truth and Measurement Setup used by NextNav.

To verify the position results, an integrated IMS platform was used. The GNSS measurements were first post processed against the base station solution and then combine with IMU for cm level reference.

For indoors positioning, pre-surveyed points were used. First GNSS survey established points outdoor. Then, using tape and laser distance measurements, coordinates of the indoor points were established in relation to outdoor points. More details can be found in [\[AD. 7\]](#).

### 5.7.3 Time Generation

The SJC network Leader was assisted by a Caesium atomic clock, with holdover capacity. To demonstrate its performance this clock was free-run for approximately 10 days. The data was

collected using NTR receiver, with the same two-hop setup used for the Time Transfer OTA Outdoor test. The results are presented in Figure 54, showing that the holdover clock has drifted less than 30 ns from its starting position, with an average error of 40 ns and peak to peak error equal to 50 ns.

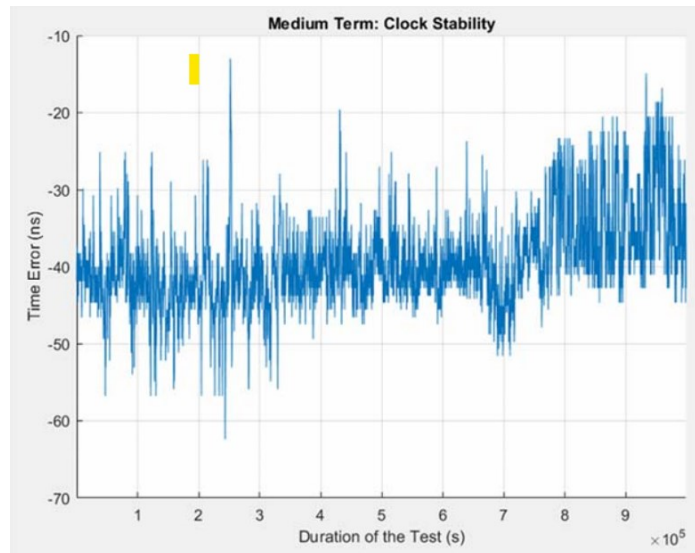

Figure 54. Time Series of Time Error in the holdover test observed on the NextNav platform.

#### 5.7.4 Time Transfer OTA Indoor

NextNav conducted timing tests indoors both at the JRC site and in the SJC. In both cases, the NTR receiver was used. At the JRC site, the time transfer was demonstrated through two network setups:

- Using one hop. The results are shown in Figure 55 (blue line). Note that the 90 ns offset was removed for the clarity of the presentation. The offset is present due to non-LOS hop;
- Using two hop network (passing through two beacons from Leader). The results are shown in Figure 55 (orange line). In this case, no offset is present as the system was able to calibrate closed loop.

Each test time was restricted to 30 minutes, due to the spectrum permit constraints. The end user receiver antenna was placed inside the BG72C laboratory.

The platform was able to transfer time within 12 ns (100 ns for non-LOS one hop results due to offset). The short-term spikes observed in the timing result likely a measurement artefact of the Calnex equipment.

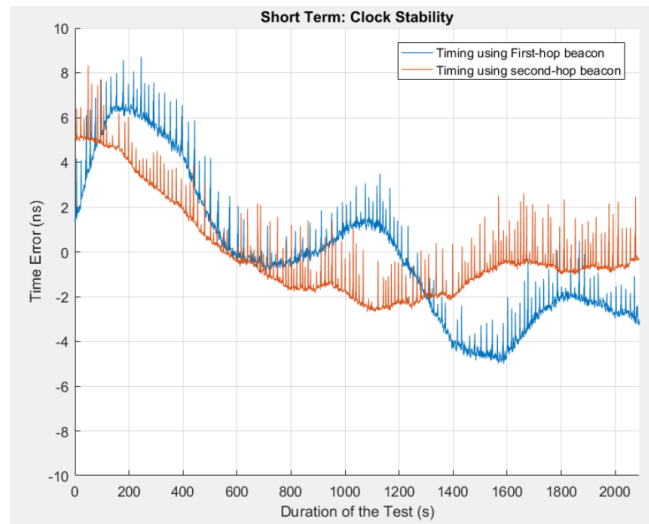

Figure 55. Time error results with the mean removed observed on the NextNav platform.

In the SJC time was transfer through two hoops, that is from Leader (CASFO0082), through Follower2 (CASFO0239, to Follower 1 (CASFO0242,)) to timing applications (NTR) receivers. This test was performed for 2 hours and the measurements at the end user terminal (NTR), measured against UTC, show average time transfer accuracy of 39 ns. More details can be found in [AD. 7].

### 5.7.5 Static Outdoor Positioning

This test was conducted at SJC. Eight points were pre-surveyed, as described in previous sections. Points EFGH are outdoor and points IJKL indoor. For outdoor points the measurements route was from point E till point H, completed twice. Each point was observed for 5 min twice.

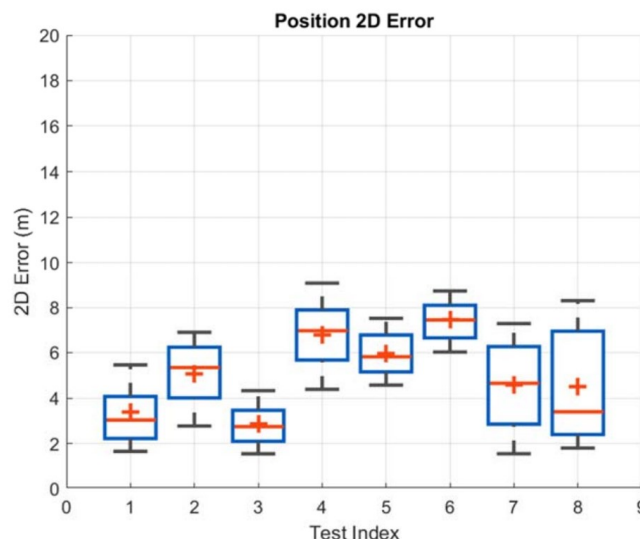

Figure 56. Static outdoor position errors (boxplot) observed on the NextNav platform.

The results from Figure 56 show that not all points follow normal distribution. All planar (2D) positions were within 9 m (95% of the time) while height, estimated using barometric observation, was within 1.2 m (95%, figure in [AD. 7]).



### 5.7.6 Static Indoor Positioning

This test was conducted at the same time as the previous test. The route for the indoor points was IJKL, also completed twice, with each point observed 5 min twice.

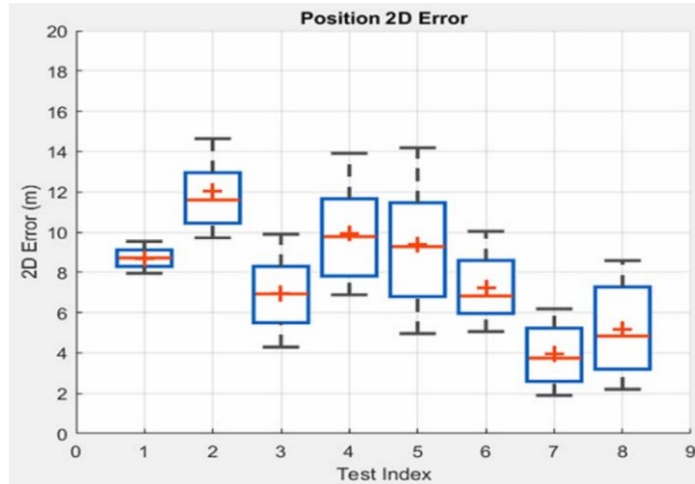

Figure 57. Static indoor position errors (boxplot) observed on the NextNav platform.

The results, presented in Figure 57, show that the position error evaluated in all the points follows a normal distribution. All planar (2D) position errors were within 14 m (95% of the time) while height, estimated using barometric observation, was within 1.6 m (95%, figure in [AD. 7]).

### 5.7.7 Kinematic Outdoor Positioning

Those tests were conducted at SJ. Two, very similar routes, each taking 20 min, were used to collect data. Routes included sub-urban and urban environments. One of them is plotted in Figure 58.

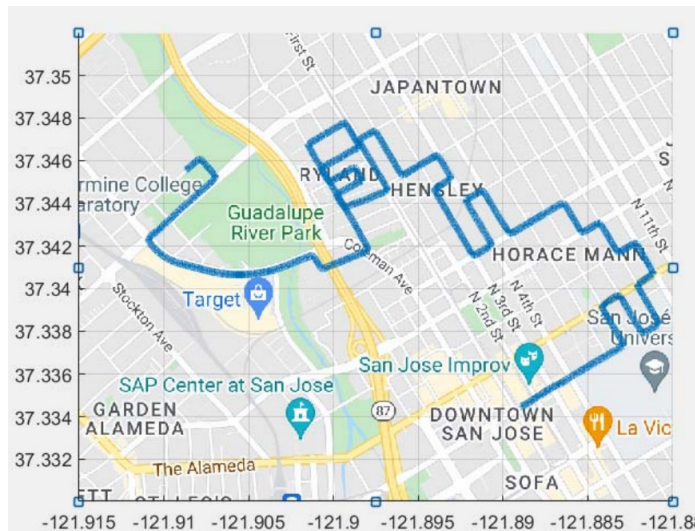

Figure 58. Planned route for the kinematic test at San Jose (CA, USA) used by NextNav.

The results, in Figure 59, show TerraPoiNT 2D performance within 10m (90% of the time) and height within 2.2m (90% of the time) [AD. 7].

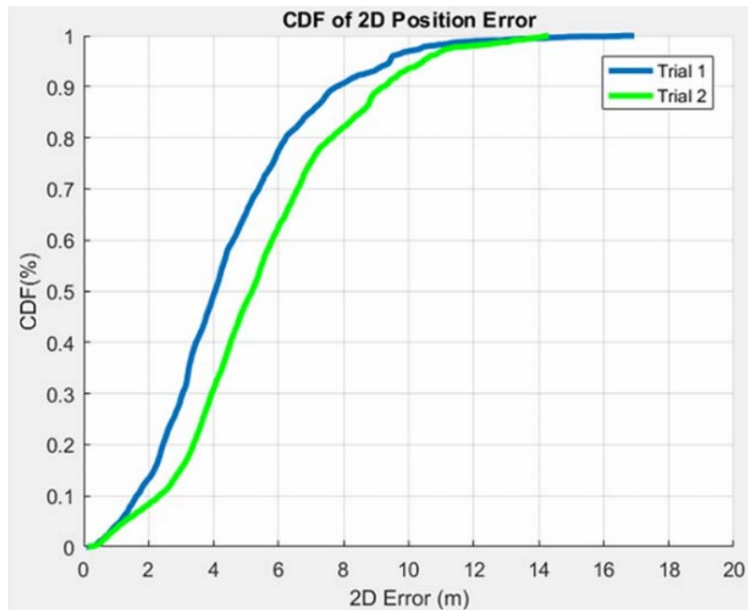

Figure 59. CDF of height error for the kinematic test at SJC used by NextNav.

### 5.7.8 Kinematic Indoor Positioning

Tests were conducted at the JRC site in building 102 using hand-held receiver. In preparation the absolute height of each floor (lower ground, ground, first, second and third) was measured and related offset (floor to the receiver held at the chest height) was added.

Test consisted of a user walking through the floors of the building. This was repeated twice with a slightly different route, as described in [AD. 7]. The results, in Figure 60, was assessed for each floor, excluding staircases. The larger differences identifiable in the figures below are due to larger than expected difference in pressure (BG102 has pressure control). Overall, the height accuracy is within 1.1m (90% of the time).

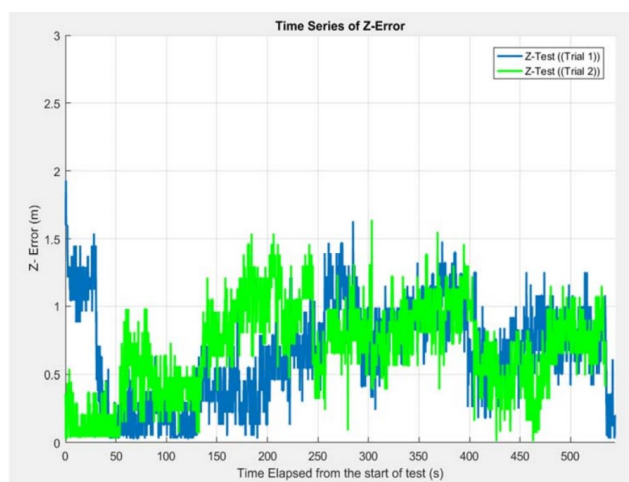

Figure 60. Time series of absolute Z error measured in the indoor tests with NextNav.

### 5.7.9 Resilience

The platform provider demonstrated the performance of the network with interruptions - is when some of the network beacons are not operational. The SJC network, consisting of 7 beacons, was



used for demonstration. As per Figure 61, three beacons (B-1, B-2 and B-3) were used by NTR receivers to obtain time. During the test those beacons were turned off one by one until only single beacon (beacon 3) remained active. Then they were turned back on in reverse order.

The timing error was maintained within 48 ns (between beacon 3 only and all three beacons active). The whole test took 3.5h.

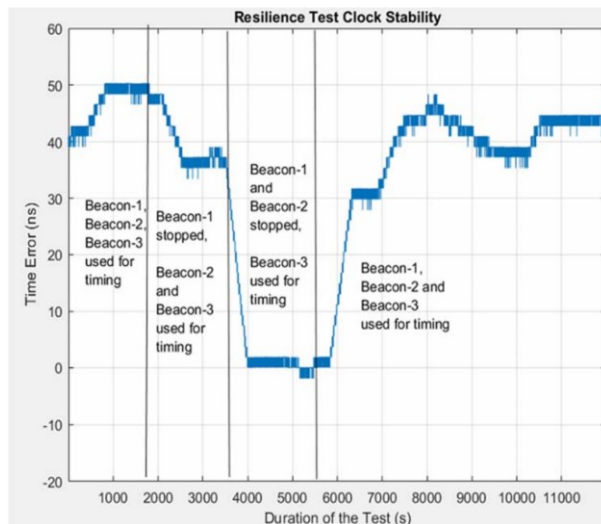

Figure 61. Time errors observed in the resilience and the network monitoring test at San Jose (Ca, USA) with NextNav.

Similarly, the SJC network was used to demonstrate the position resilience, at two locations outdoor (M) and indoor (N). In this scenario a first test was run with all beacons (baseline test). Then two out of seven beacons have been turned off. This resilience demonstration was conducted twice, with each test taking 10 min.

Results in [AD. 7] also indicate that planar and barometric height position was not visibly impacted by a reduced number of the beacons in the network.

## 6 Test Campaign Conclusions

In the framework of a call for tender (CfT) launched by the Directorate General for Defence Industry and Space (DEFIS) of the European Commission (EC) in December 2020 [RD. 1] a performance assessment campaign for seven state-of-the-art A-PNT demonstration platforms was conducted, with the scientific and technical support of the EC Joint Research Centre (JRC). **The aim of the test campaign was to establish strong and weak points of each proposed service**, by means of a set of science-based, unbiased and independent tests.

**The diversity in both the type of the assessed A-PNT technologies and the test conditions that were applied are such that a fair benchmarking of the performances cannot be made in a fair manner.** The objective of the test campaign was rather directed to characterise each technology and understand its main points of strength. In addition, it is worth stressing that, **even if the technologies performance was evaluated against common KPIs, some critical elements (including operation mode and implementation) cannot be captured by KPI metrics.**

**The main conclusion of the test campaign is that all A-PNT platforms fulfilled the minimum requirements set in the ITT, and more specifically they showed:**

- **A Timing Accuracy to UTC (3 sigma) < 1 microsecond for at least 1 day upon a GNSS outage;**
- For those demonstrating position, the **positioning accuracy (Horizontal and/or Vertical 95%) < 100 m;**
- **Availability > 99%;**
- **Resilience to GNSS failure modes and vulnerabilities**, including GNSS frequency jamming and spoofing or unintentional interference;
- **Compatibility and interoperability with existing infrastructure and legacy protocols** (incl. NTP, PtPv2, etc.);
- **Security - monitoring, secure remote access, OTA updates;**
- Integrity values were not assessed during the test campaign and are reported as estimated by the participants.

As far as time generation is concerned, **the solutions proposed are a combination of local oscillators and distributing UTC directly from the NMIs, using GNSS-independent time transfer.** This is important, as a GNSS outage lasting more than 14 days would require local oscillators with stability comparable to those of Caesium or Passive Hydrogen Masers (PHM) atomic clocks. If no such stable clocks are available, **the establishment of a permanent link allowing a precise time transfer from an NMI has been found to be a valid alternative.**

A summary of the performances of the A-PNT platforms providing timing services is given in Table 17. It must be noted that **the tests conducted on each of the A-PNT platforms are not fully comparable**, and therefore **these results should not be taken as a pure benchmark but as more a qualitative assessment of the platforms under test.** Further, the reported performances are not specified separately for the duration of the GNSS outage of 1, 14 and 100 days, and focus exclusively on the time transfer performances. The final accuracy of the system at the end user will depend on the Master Clock, while relative time transfer performance remains constant. Therefore, the first column of Table 17, indicates the length of the time generation demonstrated during the test campaign, while the Maximum Time Interval Error (MTIE) observed is reported in the second column. The participants who were able to generate time over 80 days either used

PHMs, or were connected to an NMI UTC time source, or got the time transferred over the air from a LEO constellation. The remaining columns relate to time transfer modes demonstrated and provide values in nanoseconds. In case of Locata it refers to internal time transfer with value in brackets referring to external time transfer as discussed in section 5.6.5.

Timing Performance	Time Generation [days]	MTIE [ns]	Time Transfer Fibre [ns]	Time Transfer Networks [ns]	Time Transfer OTA Outdoors [ns]	Time Transfer TA Indoors [ns]
<b>OPNT</b>	N.A.	N.A.	0.057	N.A.	< 200 ( $\pm 100$ )	N.A.
<b>7 Solutions SL</b>	80	280	0.089	N.A.	N.A.	N.A.
<b>SCPTIME</b>	1	< 1000	N.A.	35	N.A.	N.A.
<b>GMV</b>	100	57	1	500	N.A.	N.A.
<b>Satelles Inc</b>	110	364	N.A.	N.A.	145	< 340
<b>Locata</b>	1	< 1000	0.4 (4.9)	0.4 (6.1)	0.7 (6.1)	0.2 (5.2)
<b>NextNav LLC</b>	11.6	40	N.A.	N.A.	N.A.	< 39

Table 17 Summary of the results of the PUTs time performance at 99.7 percentile, values in [ns] unless otherwise stated.

In Table 18, a single value HMSE at 95% percentile was chosen to represent the positioning performance. More detailed characterisation can be found in section 5 and [AD.1-7]. In case multiple tests within the same test category were conducted, the largest mean error is reported. For the **positioning accuracy, only 2-D horizontal accuracies are reported**. In the case of NextNav, the **height accuracy in the indoor tests conducted in the JRC (not reported in the table below) was 1-2 m**. As in the case of the tests assessing the timing performances, these tests had associated specific constraints and conditions under which the positioning performance were assessed. **As in the previous case, these results should not be intended as a pure benchmark but more as a qualitative assessment of the platforms under test.**

2D Positioning Performance	Static Outdoors [m]	Static Indoor [m]	Kinematic Outdoors [m]	Kinematic Indoors [m]
<b>Satelles Inc</b>	17.0	15.0	N.A.	N.A.
<b>Locata</b>	< 0.01	< 0.01	< 0.02	< 0.02
<b>NextNav LLC</b>	9.0	14.0	11.0	N.A.

Table 18 Summary of the results of the PUTs position performance at 95 percentile, values refer to planar position and are in [m]

Please note that the overview of the tests conducted by each participant can be found in Table 1 and Table 2, which should be read alongside Table 17 and Table 18 for a full understanding.

## 7 Main Recommendations

Today, GNSS/PNT is ubiquitous and impacts practically every economic sector, with our society and economy crucially dependent on positioning, navigation and timing (PNT) services. Galileo and EGNOS boost the EU digitalisation strategy, support the EU Green Deal, and drive economic growth. A recent EUSPA study has estimated the total economic benefits of PNT/GNSS for the EU, for the 1999-2027 period, at €2 trillion and creation of more than 100,000 highly skilled jobs [RD. 2].

Space systems and services in the EU provide essential services for societal functions and economic activities. Thus, they need to be increasingly resilient and protected. The EU recognises space as a critical sector in its existing legislation on *the resilience of critical entities (CER Directive)* and *cybersecurity (NIS2 Directive)*, covering ground based infrastructure of Member States. These directives establish obligations to identify critical entities, such as energy supply networks, transport infrastructures, telecommunications, and financial networks, and to enhance their resilience. **Since these infrastructures are primary users of PNT services, we must consider the effect of the potential disruptions. Historically those included jamming, more sophisticated spoofing attacks or a malfunction in the GNSS system infrastructure.**

**The European Commission (EC) has implemented multiple regulatory actions aimed at enhancing the resilience of PNT infrastructures and services in the EU.** Those include:

- Introduction of new Galileo services with an enhanced resilience against spoofing attacks, as the *Galileo OSNMA*, plus those in the second generation of Galileo.
- The *EU Space Regulation*, requesting MS to protect EU Space ground infrastructure and stringent cybersecurity requirements for the EU Space Programmes.
- The Release of a new European Radio Navigation Plan, a reference document presenting the evolution of the landscape of PNT infrastructures in the EU to identify potential gaps and synergies in the various PNT sectoral domains.

In the framework of a CfT launched by the Directorate General for Defence Industry and Space (DEFIS) of the EC [RD. 1], a performance assessment campaign of seven state-of-the-art Alternative Position, Navigation and Timing (A-PNT) demonstration platforms was conducted, with the scientific and technical support of the EC Joint Research Centre (JRC).

Initial results of the testing and practical demonstration of the selected technologies were presented in May 2022 during a dedicated Demo Day. This report expands on those and is addressing both the verification and the technical description of the proposed technologies.

Over the eight months, the selected A-PNT platforms were tested at the JRC premises, and in a few cases, also at other locations, as agreed with the A-PNT platform providers. Such demonstrations included precise and robust timing provision and transfer, and positioning both indoor and outdoor.

To provide the UTC source, the JRC timing setup was calibrated by the INRiM, the metrology Institute providing the official Italian UTC Time. In addition, grids of permanent points, both indoor and outdoor, in the European Terrestrial Reference Frame (ETRF), were established across the site.

The test campaign was aimed to understand the maturity and nature, based on the predefined KPIs. The purpose is to establish the strong and weak points of each proposed service, without

directly competing against each other. It is worth stressing that, even if the technologies performance was evaluated against common KPIs, some critical elements (including operation mode and implementation) cannot be captured by KPI metrics.

**The results indicate that mature commercial A-PNT technologies, which can deliver positioning, and/or timing information independently from GNSS, already exist in the commercial market.**

The timing tests included transfer over long distances through fibre, computer networks and over the air. Demonstrated time transfers were at the microsecond level, with some of them at the sub-nanosecond level. This also included a 105 kilometres time transfer over the air, which utilised a 100 metres high JRC Tower and two locations outside the JRC. **Results indicate an active ecosystem of European time transfer, able to fulfill the required KPIs.** For time generation is concerned, the solutions are a combination of local oscillators and distributing UTC directly from the NMIs, using GNSS-independent time transfers.

The position demonstration was conducted by three no-EU companies - Satelles, Locata and NextNav. The accuracy of those demonstrations varied from tens of meters up to cm level, also in harsh environments. Tested technologies either require the deployment of terrestrial receivers (beacons, transceivers) or the use of the signal from the LEO constellation. **Each observation at the JRC site, indoor or outdoor, was provided within the European Terrestrial Reference Frame (ETRF).**

**The stringent cybersecurity of each A-PNT technologies demonstrated during the test campaign is very promising.** This includes secure remote access to hardware, over the air updates, monitoring and reporting. Hardware also deploys modern programming techniques such as virtualisation, allowing for rapid deployment.

The **main recommendations** from the test campaign are:

- **EU companies have excellent record in time transfer and time generation. The test campaign highlighted the important role of the NMIs across Europe,** as most of tested technologies work with them directly and un-directly. OPNT, Seven Solutions and Locata demonstrated the ability to handle multiple Master Clock inputs with voting and seamless switchovers. Interconnecting as many NMIs as possible, with possible local atomic clocks backups, would result in a very robust and resilient time architecture, independent from GNSS across Europe. The ability to provide **resilient and accurate time through the EU communication infrastructure, ideally on the nanosecond level, would also enable robust positioning,** using a combination of signals, as described in [\[RD. 5\]](#), [\[RD. 8\]](#).
- As discussed in sections 5.6 and 5.7, **there is a strong advantage in the dedicated spectrum band for terrestrial PNT services within the EU,** something that at the moment is not available. This approach already exists in the US, with a 902-928 MHz frequency band, dedicated to the Location and Monitoring Service. Not only does this offer better legal protection against RFI but also allows for more transmission power – reducing the chance of RFI, extending the signal range and in-building penetration.
- **A resilient EU PNT requires system of system approach with mix of technologies following, which are supported by industry standards to ensure the required interoperability.** All positioning technologies should operate within the European Terrestrial Reference Frame (ETRF) and timing related to time scale of UTC from an NMI.

## GETTING IN TOUCH WITH THE EU

### In person

All over the European Union there are hundreds of Europe Direct centres. You can find the address of the centre nearest you online ([european-union.europa.eu/contact-eu/meet-us\\_en](https://european-union.europa.eu/contact-eu/meet-us_en)).

### On the phone or in writing

Europe Direct is a service that answers your questions about the European Union. You can contact this service:

- by freephone: 00 800 6 7 8 9 10 11 (certain operators may charge for these calls),
- at the following standard number: +32 22999696,
- via the following form: [european-union.europa.eu/contact-eu/write-us\\_en](https://european-union.europa.eu/contact-eu/write-us_en).

## FINDING INFORMATION ABOUT THE EU

### Online

Information about the European Union in all the official languages of the EU is available on the Europa website ([european-union.europa.eu](https://european-union.europa.eu)).

### EU publications

You can view or order EU publications at [op.europa.eu/en/publications](https://op.europa.eu/en/publications). Multiple copies of free publications can be obtained by contacting Europe Direct or your local documentation centre ([european-union.europa.eu/contact-eu/meet-us\\_en](https://european-union.europa.eu/contact-eu/meet-us_en)).

### EU law and related documents

For access to legal information from the EU, including all EU law since 1951 in all the official language versions, go to EUR-Lex ([eur-lex.europa.eu](https://eur-lex.europa.eu)).

### Open data from the EU

The portal [data.europa.eu](https://data.europa.eu) provides access to open datasets from the EU institutions, bodies and agencies. These can be downloaded and reused for free, for both commercial and non-commercial purposes. The portal also provides access to a wealth of datasets from European countries.

## The European Commission's science and knowledge service

Joint Research Centre

### JRC Mission

As the science and knowledge service of the European Commission, the Joint Research Centre's mission is to support EU policies with independent evidence throughout the whole policy cycle.



**EU Science Hub**  
[joint-research-centre.ec.europa.eu](http://joint-research-centre.ec.europa.eu)

 @EU\_ScienceHub

 EU Science Hub - Joint Research Centre

 EU Science, Research and Innovation

 EU Science Hub

 EU Science



Publications Office  
of the European Union